

# QST

DEVOTED ENTIRELY TO

# AMATEUR RADIO

*Published by the American Radio Relay League*

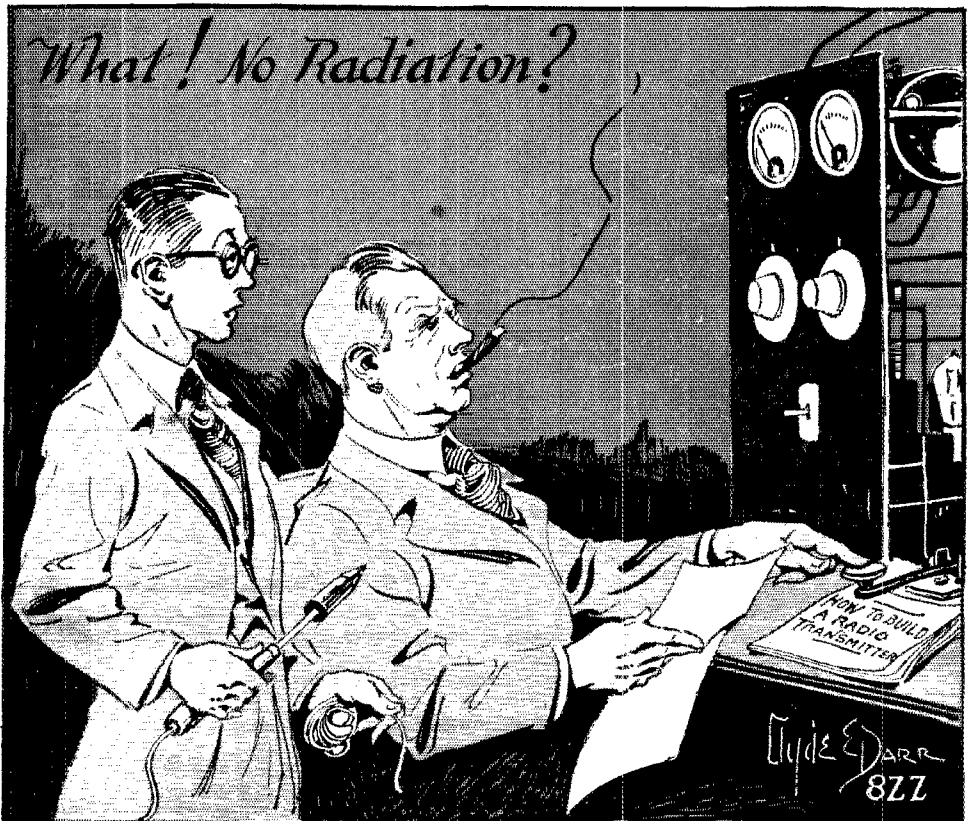

December  
1926

25¢

---

# Cunningham RADIO TUBES

Since 1915—Standard for All Sets

©  
Cunningham  
Radio Tubes

are astoundingly good all the year 'round and at Christmas time you will receive even a greater appreciation of their quality performance because of the attractive Yuletide programs being broadcast which come in clear and full-toned when your receiving set is Cunningham equipped. ¶ Every broadcast station splurges a bit at Christmas time and gives you something extra good. ¶ Entertainers are stimulated to do their best by the knowledge that thousands of new sets are tuned in and that their already large and enthusiastic audience has swelled to even larger proportions since the presents have been received. ¶ Radio sets and radio equipment in general make immensely popular Christmas gifts. ¶ Why not increase someone's pleasure a thousand fold by the gift of a radio set this Christmas? ¶ If you want to make this lucky person's happiness complete, you will make sure that the set has a Cunningham Radio Tube in every socket. ¶ To bring increased happiness to someone who now owns a receiver, give him a set of Cunningham Radio Tubes, known since 1915 as standard for all sets.

*J. Cunningham, Inc.*

NEW YORK  
CHICAGO  
SAN FRAN-  
CISCO

---

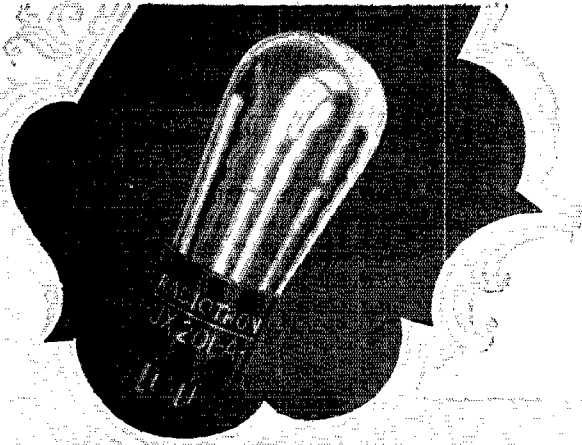

## look inside that Christmas Radio Set

THE *equipment* is as important as the set. The distance reach of a set depends a great deal on the tube in the detector socket. The over-all performance of a set depends very much on the tubes in every socket. The volume and tone quality you will get are dependent upon the tube in the last audio stage. In every point, the tubes are as important as the set. And everyone who realizes this insists on genuine RCA Radiotrons.

The research laboratories of RCA, General Electric and Westinghouse have developed Radiotrons to new accomplishment, year by year. And the manufacturing skill of these same companies keeps RCA Radiotrons far in the lead in accurate making.



### Extra! Extra! Gift Ideas for Radio fans

A "spare" Radiotron—genuine RCA Radiotron, of course—of the type he uses.

A *power* Radiotron UX-112, UX-171 or UX-210 for bigger volume and finer tone.

A special *detector* Radiotron UX-200-A for storage battery sets—for longer distance reach.

RADIO CORPORATION  
OF AMERICA  
New York Chicago  
San Francisco

# RCA Radiotron

MADE BY THE MAKERS OF THE RADIOLA

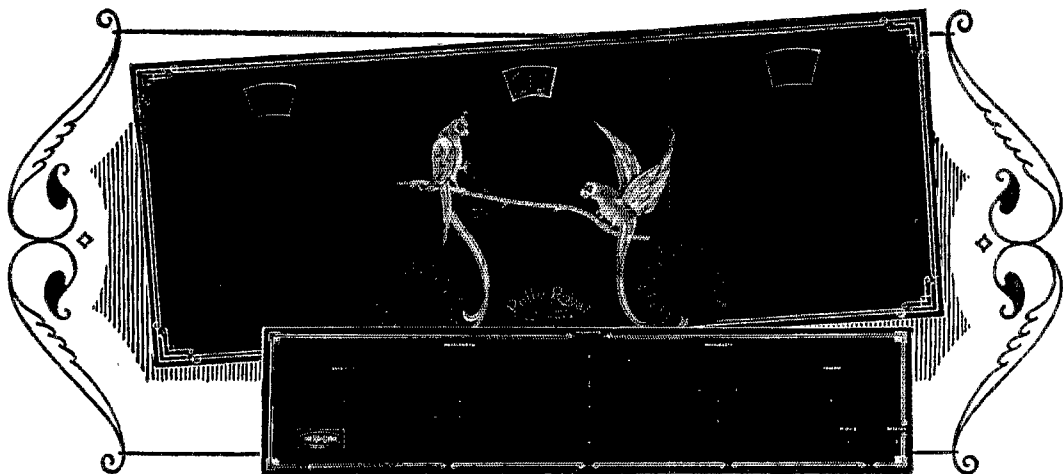

## Kit Panels With Gold Decoration

FORMICA is this year providing amateurs through the leading jobbers and dealers with handsomely decorated gloss black panels with gold decoration for the leading kits: Infradyne, Aerodyne, Bremer Tully Power Six; Browning Drake National; General Radio Universal; Victoreen Superheterodyne; Madison Moore Superheterodyne; Camfield Duoformer; St. James 8 tube; and Karas Equamatic front and sub panels, H.F.L. Nine Superheterodyne front and sub-panels.

Manufacturers are using handsomely decorated Formica panels in dull finish—some of them in two colors.

THE FORMICA INSULATION COMPANY

4620 Spring Grove Avenue

Cincinnati, Ohio

Hear the  
FORMICA  
Orchestra Tues-  
day 9 to 10  
over WLW

**FORMICA**  
Made from Anhydrous Bakelite Resins  
**SHEETS TUBES RODS**

Formica has a  
Complete Service  
on Insulating  
Material  
for Radio  
Manufacturers



# Section Communications Managers of THE COMMUNICATIONS DEPARTMENT, A. R. R. L.

<b>ATLANTIC DIVISION</b>		
Eastern Pennsylvania 8BQ Maryland-Delaware-District of Columbia 3AB Southern New Jersey 3EH Western New York 8PJ Western Pennsylvania 8XB	H. M. Walleze A. B. Goodall H. W. Densham C. S. Taylor G. L. Crossley	597 No. James St. 1824 Ingleside Terrace 149 Washington St. 598 Masten St.
<b>CENTRAL DIVISION</b>		
Illinois 9AAW Indiana 9CTQ Kentucky 9AKU Michigan 8ZZ Ohio 8BYN Wisconsin 9VD	W. E. Schweitzer D. J. Angus D. A. Downard C. E. Darr H. C. Storck C. N. Crapo	4264 Hazel Ave. 310 N. Illinois St. 116 No. Longworth Ave. 137 Hill Ave. 694 Carpenter St. 443 Newton Ave.
<b>DAKOTA DIVISION</b>		
North Dakota* 9EFN South Dakota 9BDW North Minnesota 9EGU South Minnesota 9EGU	G. R. Moir F. J. Beck C. L. Barker C. L. Barker	618 11th Street, South Fargo Milbank Henning Henning
<b>DELTA DIVISION</b>		
Arkansas* 5XAB Louisiana 5UK Mississippi 5AKP Tennessee 4KM	Dr. L. M. Hunter C. A. Freitag J. W. Gullett L. K. Rush	207½ Main St. 129 Camp St. 1708 23rd Ave. 4 Second St.
<b>HUDSON DIVISION</b>		
Eastern New York 2ADE N. Y. C. & Long Island 2CWB North New Jersey 2WB	Earle Peacock F. H. Mardon A. G. Wester, Jr.	Box 113 117-11 140th St., So. 50 Princeton St.
<b>MIDWEST DIVISION</b>		
Iowa* 9BKV Kansas 9DNG Missouri 9RB Nebraska 9BYG	A. W. Kruse P. S. McKeever L. B. Laizure C. B. Delbi	University Heights 8010 Mercer St. 3096 S. 32nd Ave.
<b>NEW ENGLAND DIVISION</b>		
Connecticut 1BM Maine 1BIG Eastern Massachusetts 1BVL Western Massachusetts 1DB New Hampshire 1ATJ Rhode Island 1BVB Vermont 1AJG	H. E. Nichols Frederick Best R. S. Briggs A. H. Carr V. W. Hodge D. B. Fancher C. T. Kerr	84 Elmwood Ave. 13 E. Crescent St. 393 Ashmont St. 36 Vassar St. 227 Main St. 22 Summer St.
<b>NORTHWESTERN DIVISION</b>		
Alaska* 7FD Idaho* 7ST Montana* 7NT Oregon* 7IT Washington* 7FD	L. H. Machin Henry Fletcher A. R. Willson A. C. Dixon, Jr. Otto Johnson	Box 452 1107 State St. 1350 East 36th St. 4340 30th St. W.
<b>PACIFIC DIVISION</b>		
Hawaii* 6RTG Nevada 6UO Los Angeles 6BUB Santa Clara Valley 6NX East Bay* 6ZV San Francisco* 6EX Sacramento Valley* 6CRS Arizona* 6ANO	S. O. Halls C. B. Newcombe L. E. Smith F. J. Quement P. W. Dann G. W. Lewis C. E. Mason D. B. Lamb	P. O. Box 2450 340 No. Painter Ave. 51 Pleasant St. 562 35th St. 748 14th St. 2530 N St. 229 W. First St.
<b>ROANOKE DIVISION</b>		
North Carolina 4JB Virginia* 3CA West Virginia 8BSU	R. S. Morris J. E. Wohlford C. S. Hoffman	413 Broad St. 118 Cambridge Ave. 126 Chantal Court
<b>ROCKY MOUNTAIN DIVISION</b>		
Colorado 9CAA Utah-Wyoming* 6ZT 7ZO	C. R. Stedman Art Johnson N. R. Hood	1641 Albion St. 247 E. 7th So. St. 1022 S. Ash St.
<b>SOUTHEASTERN DIVISION</b>		
Alabama 5AJP Florida 4QY Georgia-South Carolina-Cuba-Porto Rico-Iale of Pine 4KU	A. D. Trum W. F. Grogan H. L. Reid	217 Catoma St. Box 816 11 Shadowlawn Ave.
<b>WEST GULF DIVISION</b>		
Northern Texas 5AJT New Mexico* Oklahoma 5APG Southern Texas 5YE	W. B. Forrest, Jr. K. M. Ehret E. A. Sahn	502 Royal St. 2904 N. Robinson St. Box 569
<b>MARITIME DIVISION</b>		
Newfoundland 8AR New Brunswick 1EI Nova Scotia 1VD Prince Edward Island 1BZ	Loyal Reid T. B. Lacey W. C. Borrett W. A. Hyndman	Avalon House 6½ N. B. Power Co. 14 Sinclair St. 25 Fitzroy St.
<b>ONTARIO DIVISION</b>		
Ontario* 9BJ	W. T. Sloan	187 Cloese Ave. Toronto
<b>QUEBEC DIVISION</b>		
Quebec 2BE	Alex Reid	202 Birch Ave. St. Lambert
<b>VANALTA DIVISION</b>		
Alberta 4GT British Columbia* 5GR	A. H. Asmusen Felix E. Batt	2133 18th St. W. 211 8th Ave. E. Calgary Prince Rupert
<b>PRAIRIE DIVISION</b>		
Manitoba* 4DE Saskatchewan* 4CB	F. E. Rutland, Jr. E. L. Maynard	452 St. John Ave. Winnipeg Morse

\*Temporary officials appointed to act until the membership of the Section concerned choose permanent SCMs by nomination and election.

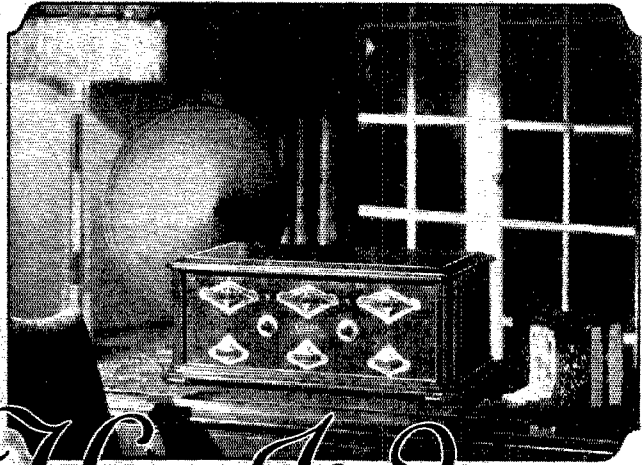

The Synchrophase is also supplied with battery base and in five beautiful console models.

# Has It?

THAT ideal set you are looking for or contemplate buying—do your tests show that it has been fully developed in

- Tone Quality?*
- Extreme Selectivity?*
- Station Coverage?*
- Easy, Accurate Tuning?*
- Simplicity of Control?*
- Durable Construction?*

Test it for these qualities; then test the Synchrophase. Compare. Be exacting.

See a Grebe dealer today.  
Send for Booklet Q

A. H. Grebe & Co., Inc., 109 West 57th St., New York  
Factory: Richmond Hill, N. Y.  
Western Branch: 443 So. San Pedro St., Los Angeles, Cal.

This Company owns and operates  
stations WAHG and WBOQ

## THE GREBE SYNCHROPHASE

TRADE MARK REG. U.S. PAT. OFF.

All Grebe apparatus is covered by patents granted and pending.



"Make conscientiousness and sincerity your first principles."  
—Confucius.

These are the principles behind the success of the Synchrophase.

*Doctor Ma*

**Colortone**  
Reg. U. S. Pat. Off.

**Binocular Coils**  
Reg. U. S. Pat. Off.  
and Low-wave  
Extension Circuits

**Usual Dial**

**Grebe Dial**

**S-L-F Condenser**  
Reg. U. S. Pat. Off.



# QST



## The Official Organ of the A.R.R.L.

VOLUME X

DECEMBER, 1926

NUMBER 12

Editorials . . . . .	7
The Northwestern Division Convention . . . . .	8
How Our Vacuum Tube Circuits Work No. 1— <i>The Hartley Circuit</i> Robert S. Kruse . . . . .	9
Detector Action in High-Vacuum Tubes . . . . .	14
When a Guy Wire Breaks . . . . .	17
A Floating Beat Note . . . . .	18
Standard Frequency Schedules . . . . .	18
Checking the Tone and Wavelength of Transmitters . . . . .	19
Pacific Division Convention . . . . .	20
The Relative Importance of Losses in Radio Receiving Systems William W. Harper . . . . .	21
Obituary . . . . .	24
Another Article on Getting Into the Sending Game . . . . .	25
A Beautiful Portable Set . . . . .	26
Devising a Shielded Receiver Kit . . . . .	27
Book Reviews . . . . .	31
As Others See Us . . . . .	32
A Break-In Relay . . . . .	34
A Shielded Short-Wave Receiver . . . . .	37
KFHW and the Trans-Pacific Yacht Race . . . . .	41
Voltage Breakdown in Transmitting Condensers . . . . .	42
A. R. R. L. Information Service Rules . . . . .	43
Experimenters' Section Report . . . . .	44
de1XL, University of Michigan Greenland Expedition . . . . .	47
Transmitting Hints . . . . .	49
Amateur Radio Stations z2XA, 3VX, 7IT . . . . .	50
Calls Heard . . . . .	54
I. A. R. U. News . . . . .	57
Correspondence . . . . .	62
HAM-ADS . . . . .	107
QRAs . . . . .	109
QST's Index of Advertisers . . . . .	110

QST is published monthly by The American Radio Relay League, Inc., at Hartford, Conn., U. S. A.  
 Official organ of the A.R.R.L. and the International Amateur Radio Union

Kenneth B. Warner (Secretary, A.R.R.L.),  
 Editor-in-Chief and Business Manager

F. Cheyney Beekley  
 Managing Editor and Advertising Manager

Robert S. Kruse,  
 Technical Editor

John M. Clayton,  
 Assistant Technical Editor

David H. Houghton,  
 Circulation Manager

Subscription rate in United States and Possessions, Canada, and all countries in the American Postal Union, \$2.50 per year, postpaid. Single copies, 25 cents. Foreign countries not in American Postal Union, \$3.00 per year, postpaid. Remittances should be by international postal or express money order or bank draft negotiable in the U. S. and for an equivalent amount in U. S. funds.

Entered as second-class matter May 29, 1919, at the post office at Hartford, Connecticut, under the act of March 3, 1879. Acceptance for mailing at special rate of postage provided for in section 1103, Act of October 3, 1917, authorized September 2, 1922. Additional entry as second-class matter, acceptable at special rate of postage provided for above, at Springfield, Mass., authorized September 17, 1924.

Copyright 1926 by the American Radio Relay League, Inc., Title registered at United States Patent Office.  
 Member of the Radio Magazine Publishers' Association.

# THE AMERICAN RADIO RELAY LEAGUE

The American Radio Relay League, Inc., is a non-commercial association of radio amateurs, bonded for the promotion of interest in amateur radio communication and experimentation, for the relaying of messages by radio, for the advancement of the radio art and of the public welfare, for the representation of the radio amateur in legislative matters, and for the maintenance of fraternalism and a high standard of conduct.

It is an incorporated association without capital stock, chartered under the laws of Connecticut. Its affairs are governed by a Board of Directors, elected every two years by the general membership. The officers are elected or appointed by the Directors. The League is non-commercial and no one commercially engaged in the manufacture, sale or rental of radio apparatus is eligible to membership on its Board.

"Of, by and for the amateur", it numbers within its ranks practically every worth-while amateur in the world and has a history of glorious achievement as the standard-bearer in amateur affairs.

Inquiries regarding membership are solicited. A bona fide interest in amateur radio is the only essential qualification; ownership of a transmitting station and knowledge of the code are not prerequisite. Correspondence should be addressed to the Secretary.

## OFFICERS

*President*  
HIRAM PERCY MAXIM  
Hartford, Conn.

*Vice-President*  
CHAS. H. STEWART  
St. Davids, Pa.

*Communications Manager*  
F. E. HANDY  
Hartford, Conn.

*Treasurer*  
A. A. HEBERT  
Hartford, Conn.

*Secretary*  
K. B. WARNER  
Hartford, Conn.

## DIRECTORS

*President*  
HIRAM PERCY MAXIM  
Drawer 4  
Hartford, Conn.

*Vice-President*  
CHAS. H. STEWART  
St. Davids, Pa.

*Canadian General Manager*  
A. H. K. RUSSELL  
5 Mail Bldg.  
Toronto, Ont.

*Atlantic Division*  
Dr. EUGENE C. WOODRUFF  
234 W. Fairmount Ave.  
State College, Pa.

*Central Division*  
CLYDE E. DARR  
137 Hill Ave., Highland Park,  
Detroit, Mich.

*Dakota Division*  
C. M. JANSKY, JR.  
Dept. of Elec. Eng., U. of M.  
Minneapolis, Minn.

*Delta Division*  
BENJ. F. PAINTER  
424 Hamilton Nat'l Bank Bldg.  
Chattanooga, Tenn.

*Hudson Division*  
DR. LAWRENCE J. DUNN  
480 East 19th St.,  
Brooklyn, N. Y.

*Midwest Division*  
PORTER H. QUINBY  
Box 134A, Route 6,  
Omaha, Neb.

*New England Division*  
DR. ELLIOTT A. WHITE  
4 Parkway,  
Hanover, N. H.

*Northwestern Division*  
K. W. WEINGARTEN  
3219 No. 24th St.,  
Tacoma, Wash.

*Pacific Division*  
ALLEN H. BABCOCK  
65 Market St.,  
San Francisco

*Roanoke Division*  
W. TREADWAY GRAVELY  
503 Main St.,  
Danville, Va.

*Rocky Mountain Division*  
PAUL M. SEGAL  
c/o District Attorney  
West Side Court Bldg.,  
Denver, Colo.

*Southeastern Division*  
HARRY F. DOBBS  
c/o Dobbs & Wey Co.,  
Atlanta, Ga.

*West Gulf Division*  
FRANK M. CORLETT  
2515 Catherine St.,  
Dallas, Tex.

Address General Correspondence to Executive Headquarters, Hartford, Conn.

# EDITORIALS

**B**UDLONG seriously informed me the other day, after digging into some big-wig's book, that I had been violating all editorial canons by signing my initials to editorials written in the first person plural—the editorial “we”. He says that if I want to write that way I should leave them unsigned, but that if I want to sign them I should use the hated vertical pronoun.

Terrible! But not as devastating as it sounds. This page has been signed for the last couple of years because members have insisted upon knowing who is doing the preaching each month. But, with rare exceptions, I have never used “we” in the editorial sense, to mean the Headquarters editorial staff as distinguished from the readers of this great journal, nor as a convenient blanket of mysticism behind which to launch my personal views. When I say “we” I generally mean all of us in the League—you members who read this page, the rest of the fellows at Headquarters, and me; in short, we of the A. R. R. L. family. Our problems and our successes are all common to all of us as members of our League. I admit I find it a relief to discover a real justification for dropping into the distinctly personal vein if ever I am led to believe that it will be more effective in making my point, but I propose to constitute myself a wobbly note and flit blithely from singular to plural and back again, and I hope nobody minds.

Now to get a few items off the hook:

**W**E'VE discovered a new way of increasing the membership of the League. All we have to do is include all of the people who seem to *think* they are members, and bingo!—up go the antenna amps. We've just been checking up the nominating petitions for Director, the petitions which require the signatures of ten or more members, and a surprising percentage of the signers are not members. There has been no dishonest intent; obviously these people think they are members, and their interest in participating in a nomination indicates that they ought to be. The same thing is true in the Communications Department's nominations for Section Communications Manager. Handy was telling me the other day that about three quarters of these nominations received by him

are invalid because they haven't the signatures of enough members.

The answer must be that these folks are former members who have let their membership lapse. Probably they're getting *QST* monthly from the 'stands and still feel like members, but they can't expect to participate in our affairs like a member. Headquarters carries names in arrears for ninety days and then drops them. Every member has a certificate, showing the date to which his dues are paid. Are you by any chance in this unfortunate class? Take a look at your certificate—the date will tell the story. And isn't this the psychological place to call attention neatly to the presence in every *QST* of a convenient application blank? It's just as useful for renewals and its despatch gives one such a contented feeling!

**T**HE long-postponed international radio conference comes off in Washington early next year and we're wondering what's going to happen to short waves. Everyone knows that the wonderful possibilities which we amateurs displayed as residing in the high frequencies have attracted all manner of commercial interest in their exploitation. Numerous high-power commercial stations have come into existence recently and many more are planned. The variety of services which see improved possibilities for themselves in short waves is simply staggering. The area which was once the exclusive property of the amateur is bound to be bitterly-contested ground at this conference, with the possibility even existing that an attempt will be made to partition the short waves amongst the various nations as was done with the long waves. With every nation now barely able to find enough channels for all her classes of service when parcelling out the whole spectrum below 200 meters, one can imagine the difficulties when a nation agrees to forego all but a little slice for all her varied interests. And in the many countries where amateur radio is not as firmly grounded and as well recognized as a useful institution as it is in this country, one can have a terrible nightmare by trying to imagine how many channels will be left for amateur use when commercial greed and government autocracy have had their fill.

For the United States amateur the situation is further complicated by the expectation that a new domestic radio law will be enacted about that time, thus vacating all the amateur rights now established under the 1912 law. Until new classifications and allocations are made under the new law (it seems sure to happen) we will have no status, no privileges. One can see approximately where we get off if, about that time, our country becomes party to an international agreement that partitions the short waves, and our new regulations are based thereupon. We hope that sound technical counsel will be available and will prevail at this international conference. There are ways out. We don't think any partitioning is necessary at all; but if it is decided to be,

it doesn't need to be by countries. By continents would be just as satisfactory, for it is the prevention of inter-continent QRM that brings up the subject. Partitioning by services seems to us still more desirable, if there must be division. Doubtless we amateurs could acclimate ourselves to life in several husky bands and do our own little private allocating around the world if, again, it seems necessary. We have the idea that if the conference does decide on partitioning, there will be made available for amateur use all around the world substantially the same short-wave bands now allocated to United States amateurs. Meanwhile the officers of the League and of the I. A. R. U. are keeping in touch with the situation.

K. B. W.

## The Northwestern Division Convention

ONE of the most successful conventions ever held in the Northwestern Division was held at the Tacoma Hotel, Tacoma, Washington, Oct. 8 and 9, under the auspices of the Radio Club of Tacoma, an affiliated A. R. R. L. organization. Over seventy hams registered from all parts of the Division, which is a mighty big one, territorially. 7PU of Hamilton, Montana, and 7PE of Cloverdale, Oregon, were first to register and from the time of registration, on, there was a good attendance at all the meetings and big doings that had been planned.

The convention was officially opened on behalf of the convention committee by Chairman K. W. Weingarten. The first day was started with a live traffic meeting. Mr. A. A. Hebert spoke at some length on the new Communications Department organization. 7EK, former D.M. of the Division, spoke, stressing the importance of reporting on time each month. 7PU told the gang how to obtain and handle traffic. Next, the gang adjourned to the club station, where various groups hamfested and took a whirl at the key of 7DK.

The Friday evening meeting was the main technical session of the convention. There was a lively discussion following a paper on skip distances by A. R. R. L. Fieldman A. A. Hebert. Howard Mason, 7BU, gave the gang the dope on crystal oscillators in his usual clear and complete fashion. The gang adjourned at a late hour, splitting into groups to hamfest at the club shack or to visit various Tacoma stations and pound brass into the wee small hours.

Saturday morning at ten o'clock all hands

were loaded into cars for an inspection trip. The 500-watt wired-wireless installation at the City of Tacoma's new municipal plant got most attention as everyone was interested in the details of the intricate calling system employed. Saturday afternoon there was a general meeting with more interesting talks. Mr. Hebert gave a short but informative talk about A. R. R. L. Headquarters and general League subjects. Bob Wasky next told the story of the hardships encountered by the Wilkins' expedition in going across Alaska with a scanty food supply and of radio conditions in the Arctic with a 201-A battery-supplied transmitter. Mr. E. E. Tugby, who chases power leaks for the Puget Sound Power Company, told of the many different kinds of elusive QRM and related many humorous incidents of his travels as a professional trouble-shooter. The meeting broke up to let the official photographer do his stuff and to inspect the 500-watt Western Electric equipment at the local broadcasting station.

The big banquet was the final event on the program. At each plate was a QSL-card of 7DK bearing the menu on the reverse, something novel in this line.

After a general loosening of belts and some entertainment, Mr. Tugby, Radio Supervisor Clark, Mason, Wasky, Hebert, the officers of the Tacoma Club, and members of the convention committee spoke briefly. Some valuable prizes were awarded thru the courtesy of QST's advertisers. Spokane was selected as the place for the next convention. Although it was about midnight, no one wanted to go home, so Director Weingarten, who acted as toastmaster, called on almost every ham in the room for a few words. The gang said their good-byes at two o'clock Sunday morning and started for home.

—K. W. W.

# How Our Tube Circuits Work

## No. 1—The Hartley Circuit\*

By Robert S. Kruse, Technical Editor

**T**HERE are not very many *kinds* of oscillating tube circuits, though there are almost endless variations of each of the kinds. It isn't necessary to understand more than a few before one begins to see how the others must work. To explain a few standard oscillating circuits *simply* is the purpose of this series of "baby articles"—which does not mean articles for babies, but refers to the space they take up in the magazine.

The reason for beginning on the Hartley circuit is that it seems about the simplest to use and therefore the first that one will try in a transmitting set. It would be a shade easier to start the explanation with the tickler circuit and—all right, let's do it that way.

Referring to Fig. 1A, we have an ordinary tube connected up so that the filament is hot and the plate current is flowing—but nothing in particular is going on that is either interesting or useful for reception or transmission. If in some way (never mind just how) we made a small current flow for a moment in the coil L1 the result would be to change the voltage on the grid of the tube for a bit, and as we all know the performance would be repeated in the plate circuit—*amplified*.

The last word in that paragraph was important; everything that follows depends on that one word and it must be remembered. Let us say it again; everything that is done in the grid circuit will be repeated in the plate circuit but will be amplified, will happen on a larger scale. Now if the thing happens on a larger scale in the plate circuit it **MUST** represent more power. In fact, it does represent more power and this is the thing that lets us make the tube oscillate.

### The Tube Begins to Regenerate

Now let's go over what has happened.

1—We made a small current flow for a little while in L1—a current "pulse."

2—This put a small electrical charge on the grid for a moment.

3—A current like 1 (but bigger) occurred in the plate circuit—a "pulse" again, but on a larger scale.

Now then—what's to prevent us from taking a little of the big pulse of No. 3 and passing it back to the coil L1 and making the whole thing go thru the tube again and be made still bigger and so on and so on?

The answer is; no reason at all, it is per-

fectly practical. One only has to put a coil L2 in the plate circuit as shown in Fig. 1B, put that coil near L1 and everything is ready to go. L2 and L1 are a transformer; anything that happens in one coil is repeated into the other coil and the show keeps on with the "pulse" getting stronger

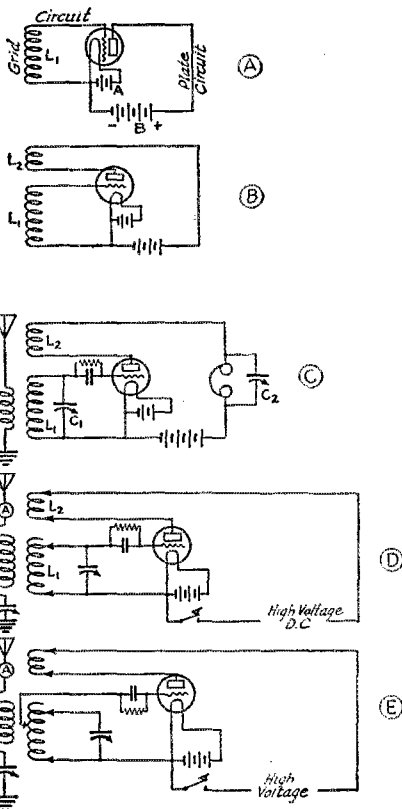

FIG. 1

each time it goes thru the tube and gets back again to L2. We wind up with a much stronger pulse than we had in the first place.

### Putting the Idea to Work

Reasoning along exactly that line, several of us in 1917 rigged up a receiver like that shown in Fig. 1C, which is the same thing we have been talking about with the difference that we have added an antenna

\* The first of a series—the next to appear in an early issue of QST.

system, a tuning condenser C1 and a pair of phones with their little by-pass condenser C2. We *thought* we had invented something for we had never heard of the use of a tickler—and I described our “invention” quite seriously on page 11 of *QST* for September of the year 1917. If any of you have that ancient green-colored *QST* you will find that the article brags about the very great increase in signals that resulted. Later on, we found that the thing had been done before and was almost as ancient as

the familiar “plop” in the phones and know that the tube has started to “oscillate.”

Fair enough—but *what has happened?* The answer is this. We have managed to increase the “feed-back” of energy from L2 into L1 until the thing is going on by itself, passing a pulse around and around thru itself and going right ahead with this performance continuously. We no longer need to hand it a “pulse” each time to get it going, the thing is automatic and keeps right on swinging.

How fast does it swing? At the rate to which the circuit L1-C1 is tuned. If that circuit happens to have in it the 8-turn “B” coil of an Aero products kit and the condenser is a 140-picofarad Karas, set at full scale, this circuit will be tuned to 30 meters or 10,000 kilocycles and that’s the rate at which our tube will pass pulses around thru itself.

### Transmission or Reception

Now we have an affair that can be used for c.w. reception or spark reception by simply working the tickler back and forth as needed. The same circuit can be modified in enough ways to make a person’s hair stand on end—and every one of the modifications is credited to at least three people in different countries.

If you have ever lived near one of these affairs you know that it is also a transmitter. It can be made into a better transmitter by using a larger tube and making the slight changes shown in Fig. 1D.

### Practical Transmitting Circuits

Now we will begin to sneak up on the Hartley circuit, which you have probably forgotten during all this talk.

Looking at Fig. 1D one will notice that there are several things about the circuit that makes it rather poor for transmission. For one thing we will have some difficulty getting three coils near each other at the same time without having fireworks because all the coils must have clips on them and these clips have a discouraging way of sticking out in the wrong direction and making connections with something else. That’s really reason enough for avoiding the circuit, especially at short waves where room is always scarce. If another reason is needed, it will be found when one tries to adjust the circuit so that there will be a decent output to the antenna without having excessive strain on the grid. It is very easy to heat the grid red hot and the filament up to the melting point. The trick of Fig. 1E gets around this partly, but adds *another* clip.

All of this can be gotten around very easily by simplifying the circuit a bit—which will incidentally give us the Hartley circuit.

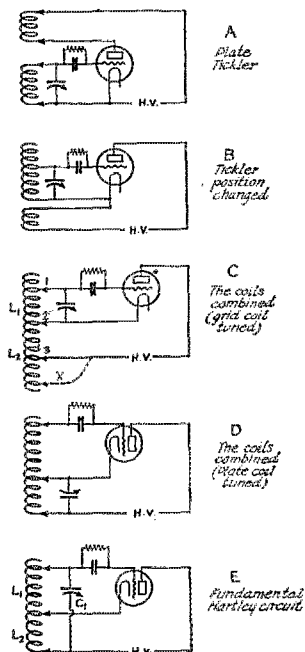

FIG. 2 — DEVELOPING THE HARTLEY CIRCUIT FROM THE PLATE-TICKLER-CIRCUIT

the “tuned plate” idea which we will come to later. We didn’t care, we had the effect we were after. A signal would arrive at the antenna from some amateur spark station 600 miles away, barely able to transfer itself to the coil L1; immediately after which it got flipped thru the tube and then back to L1 again until there resulted a booming signal that could be heard all over the house. The amplification one could get with one audion on those old spark signals was something tremend—but never mind that. This isn’t supposed to be a history.

### The Tube Oscillates

Now if we put the coil L2 quite close to L1 we get more of this “regenerative” amplification we have been talking about. The closer the two coils come the more the thing “regenerates” until suddenly we hear



Referring to Fig. 2A, we have again the tickler-feedback arrangement in its simplest form, just as it appeared in 1B. Now in 2B we have swapped the positions of the tickler coil and the h.v. (high voltage). This isn't a very practical arrangement, but we are only going to use it for a moment so it will do. Looking at 2B at once suggests that a single coil would do the job since the two are in line and connected together at the ends. 2C shows such a single-coil arrangement, but if we try to work it very hard this affair will show the same difficulty that we found before—the tube will want to overheat. A little thought will show that the difficulty lies in the location of the different connections on the coil. The tuned part of the coil will have quite a voltage across it, even though there are only a few turns between the filament clip 2 and the grid clip 1, while the lower part of the coil (L2) will only have such voltage across it as is picked up from L1 by transformer action—and that generally isn't enough. Of course, one thinks of putting the plate clip 3 further out on the coil as shown in "X" of Fig. 2C to pick up more voltage and that does help somewhat, but not all that is desired, partly because these last turns are so far away and partly because of an "out-of-phase effect" that is even worse to explain than it sounds.

The next thing that one thinks of is to change the condenser over to the plate end of the coil as shown in Fig. 2D, and that isn't half bad, although there will now be a tendency for the grid to take too much current.

Finally, one is likely to fall on the idea of tuning *both* coils as shown in Fig. 2E—and then one has the Hartley circuit in its simplest form. It is a perfectly practical oscillator in this form and has been used very widely for laboratory oscillators and low power transmitters.

### Hartley Receivers and Transmitters

Now it is a pretty fair electrical rule that one can always use a generator as a motor—or a transmitter as a receiver. With a few exceptions, that applies to all of our circuits. So, too, the Hartley circuit makes a good receiver or transmitter, provided one makes a few changes to fit the job.

Let us move on to Fig. 3 and take a hard look at Fig. 3A so as to memorize the fundamental circuit well. Perhaps it will help to say that this is the simplest form of the circuit and that it was devised (along with a lot of variations) by R. V. L. Hartley of the Western Electric Co. from which so many good things in radio came. (Did you know that the Colpitts circuit also hails from there?)

### The Actual Transmitter

Now suppose that we try to use this nice simple circuit for transmitting. We will very promptly run into a whole family of difficulties which will require slight modifications of the circuit. Referring to Fig. 3A, we see the same "fundamental circuit" that we have just talked about. To convert it to a sending circuit we intend to use a larger tube with higher plate and filament voltages, and to add a key to turn the plate voltage off and on. This sounds simple; we only need to connect the thing as shown in Fig. 3B and we are all ready to go. Let's try it.

Hello—what makes the plate transformer smoke? Shut it off before something burns out! What's the matter?

That isn't hard to answer. As soon as the tube started to oscillate the radio frequency tried to go to earth via the filter and rectifier and the 110-volt wires as shown by the dotted line. The insulation of the plate transformer P. T. didn't stop it at all; it just went ahead thru the capacity of the windings, as shown by the dotted line. That was why the tube and the transformer were both so hot. This scheme was o. k. when we used B batteries on the plate but not when we use a rectifier-filter, a generator, or anything else driven by the 110-volt line. We can get out of this difficulty by putting a ground on the system at "G1," but the immediate result is that we have the whole d.c. plate voltage on the filament circuit and if the operator isn't killed by touching the key, we at least have a good chance of burning out the filament transformer by having the high-voltage plate current cut thru the path suggested by the arrow. Even if we make a filament transformer that has plenty of empire cloth between the windings we still have a hot key, and there isn't any other very good place to put the key—at least not when the whole system is "hot."

There are other possible locations for the ground connection but they mostly "load" the key and we are no better off. We *will* be better off with the ground at G2. Then the key and the filament transformer are safe. Let us put the ground there and try to invent a way of keeping the r.f. out of the filter. Clearly the way to do that is to let it go by the filter via a bypass condenser and in addition to discourage it from thinking about the filter by putting in some choke coils. This gives us the combination of Fig. 3D which is a perfectly practical one, provided only that the chokes (R.F.C.) are good enough.

This arrangement can be simplified a bit further by connecting the minus (negative) side of the filter *direct* to the ground and

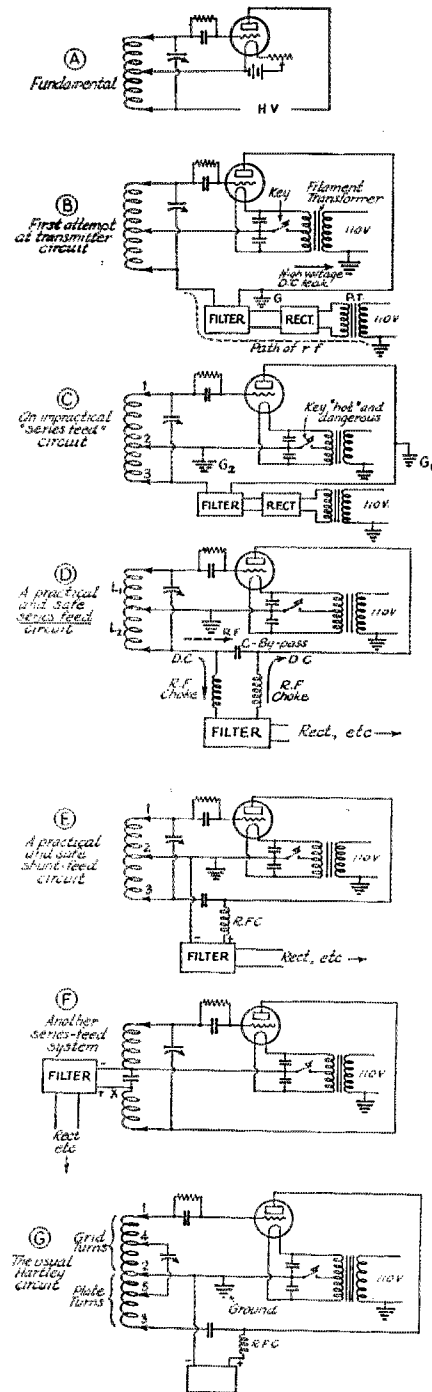

FIG 3 — DEVELOPING PRACTICAL SENDING CIRCUITS

filament, instead of making it get back thru the coil L2. Then we have the arrangement of Fig. 3E, which is the one most of us use.

**Shunt and Series Feed**

You will notice that 3D is labelled "series feed" and 3E is labelled "shunt feed." This is a difference which isn't really important but is often talked about—and argued over. There are a number of varieties of each arrangement but in general the "series feed" systems cut the plate lead (or the helix) put a condenser across the gap and connect the filter across that gap (with or without r.f. chokes). The shunt systems start out by connecting the plate supply direct from filament to plate and then putting in any chokes that become necessary. It isn't really a big difference—in one case the plate supply is connected across a part of the plate circuit—in the other case across all of it.

**The Troublesome R.F. Choke**

In the practical circuits we have had r.f. chokes—and they are a nuisance. If one becomes annoyed by them enough, one can resort to the series feed system shown in Fig. 3F—provided one can find a condenser that is good enough to stand the full radio-frequency current that is going around the tuned circuit (several amperes) and is still of big enough capacity so there will not be a very big voltage across it. If one tries to use an air condenser, the capacity isn't enough and one gets up so much radio-frequency voltage across the thing that an r.f. choke is needed again in the positive side of the line at "X." Then one has not gained anything except that the choke doesn't have quite so much work. On the other hand, one has had to cut the helix and put the condenser in the center of it. If one tried to use a large (paper or mica) condenser to get the voltage down, the condenser will burn up with almost absolute certainty.

**Raising the Efficiency**

Very well, let us conclude that circuit 3E is good enough, just as perhaps half the transmitting amateurs of this country have. When we try to work this circuit at full power we find that the tube runs rather too hot, both the plate current and the grid current are larger than they ought to be. A little cutting and trying also shows us that we can't adjust these things without adjusting the wavelength at the same time—for the only adjustment we have is to move the plate and grid clips 1 and 3. To get around this we usually add two additional clips as shown in Fig. 3G.

**Adjusting the Circuit**

This is no place to go into details on transmitter adjustment. That was covered

in the very good article, "Adjusting the Transmitter" which appeared on page 23 of the June, 1925, issue. If you do not have it, get it. Briefly, clip 3 controls the input to the tube; the further down the coil (away from the filament clip) it is set, the less power the tube takes from the plate supply system. Clip 1 controls the "grid excitation"; if it is too close to the filament clip (2) the tube will not oscillate well; if it is too far away from 2 the tube efficiency will be bad. Generally it is a good idea to use as many plate turns and as few grid turns as possible. In practice, this means something like 2 or 3 plate turns for each grid turn. One can argue forever about the proper places for clips 4 and 5. They should always be "inside" of 1 and 3. Naturally, the fewer the turns between 4 and 5 the more capacity one needs in the variable condenser. This is good and tends to steady the wave up to a certain point, beyond which the tuned circuit seems to lose control of the tube's action. Various things then happen—the tube works irregularly, gets hot and what not. My own rule is to have clip 4 about  $\frac{1}{2}$  of the way up toward clip 1 and to have clip 5 about 1-3 of the way down toward clip 3. Everyone else who has used the circuit will object—and I'll not reply, for you are welcome to choose your own combination. But at least—use plenty of condenser, it isn't much use to attempt getting steady action out of an 80-meter job that is trying to struggle along with an unsteady line voltage (they mostly are unsteady) and a tuning condenser of 120 picofarads or even less. 500 picofarads is much more like it—though one needs a good helix to allow the rather large current to circulate without bad losses. That was covered on page 29 of the July, 1926, issue. A picofarad, by the way, is the same thing as a micro-microfarad and has the advantage that it can be abbreviated "pfd.", which does not take any Greek letters.

#### Connecting to the Antenna

So far we have talked as if the oscillator were all that there is to the system sending. That isn't so, of course, for we can use a Hartley oscillator to feed any possible sort of an antenna—vertical, horizontal, slanting, straight, bent, loop, multiple-tuned, grounded, ungrounded, and of any particular type—Hertz, Marconi, Zeppelin or anything else you happen to think of. Finally we can feed these assorted antennas by bringing them to the oscillator (or the oscillator to them) or else we can feed thru some sort of a feed line—single, double, tuned or untuned. All thru the whole business the Hartley oscillator stays a Hartley oscillator. The kind of antenna and the kind of feed system doesn't change that at all.

Just which of the various antennas and feed systems you should use is entirely too long a subject to drag in here. Antennas seem to go by fashions mostly in the United States and the feeding systems were given all the space they deserved on pages 8 to 14 of our July, 1926, issue.

### Strays

This actually happened recently, to a good ham we all know. Said ham was going across on a C.P. ship to England, and had several listening tests with a friend in the States. Everything went well until he wanted to tell the friend that his sigs were being received OK on the ship. He wanted to send a message with just as few words as possible, so the message was as follows:

To John Smith, Pocahontas, Virginia  
—...— R —...— (sig).

The message was filed with the op on the ship, and the op called the nearest coastal station, started the message and got OK down to the text when the following transpired:

Coast Station "RepeatText"  
Ship "R"  
Coast Station "Yes, but repeat text"  
Ship "R"  
Coast Station "If R, R"  
Ship "No, not 2 R's, only one R"  
Coast Station "Can't you read, go ahead and fetch senior op"  
Ship "R"  
Coast Station "Yes, OM I want text"  
(senior op then takes key)  
Coast Station "Other op can't read pse qta text"  
Ship "R"  
Coast Station "If I have any further delay to traffic I shall report you"  
Ship "The text is R R R"  
Coast Station "Is that one, two or three R s"  
Ship "One R"  
and finally the Coast Station said "r ok", hi!

P. L. Whitman of Halifax, N. S., has been granted a patent on a very nifty "universal time" dial by means of which the time of day in any country in the world can be told at a glance at the Big Ben. Two paper dials are to be attached to the face of Ben, one dial being graduated in five-minute divisions from midnight till 2400 (G.M.T. fashion). The second dial fits over the first one and when properly set for your local time will give the time in the principal countries of the world. For the smaller countries a list of time zones is given in addition.

# Detector Action in High-Vacuum Tubes

Lloyd P. Smith\*

**N**UMEROUS articles have been written on the subject of detection by means of the familiar high-vacuum tube, yet the subject is more interesting than ever, because of the stress being laid on good quality reception. Two

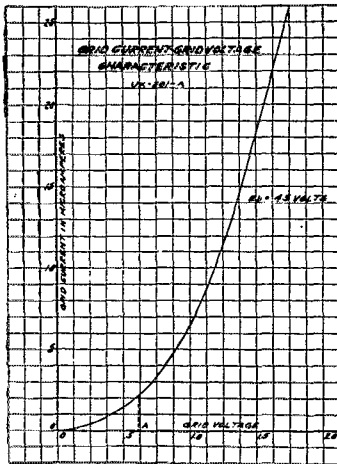

FIG. 1

common methods of detection will be discussed and the difference in sensitivity and quality will be pointed out.

## Grid Rectification

It is a well-known fact that if a curve of grid current for various grid voltages is taken for a common high-vacuum tube, such as the UX-201-A, a curve of the form shown in Fig. 1 is produced. It is this curved characteristic of the tube that makes the usual method of detection possible. Let us see how this characteristic is used. To do this it will be found convenient to forget about the plate and the plate circuit for the time being. For the purpose of explanation, let us take the grid characteristic curve of the UX-201-A as shown in Fig. 1 and also the circuit which is used with this tube for detection with the grid leak and condenser (Fig. 2). Under these conditions the grid will assume a potential which (referred to the "—" end of the filament) will be less than the five volts on the filament by an amount equal to the voltage drop through the grid leak. The current flowing to the

grid will be some value  $g_i$ . The resistance of the leak should be such that the grid potential corresponds to a point on the grid characteristic where the curvature is the greatest, such as the point (A) Fig. 1. When an unmodulated radio frequency wave is impressed on the grid under these conditions, there will be an increase in the direct current flowing to the grid. The reason for this, is that when the grid potential swings more positive on one half of the cycle there is an increase in grid current and when the grid swings more negative than the point a, on the next half of the cycle there will be a decrease in the grid current. On account of the curvature of the characteristic, the increase is greater than the decrease, and the result is an increase in the average current flowing to the grid. This increase in grid current would not of itself cause any change in the plate current of the tube, but since the increase in grid current must flow through the grid leak, the voltage drop across the grid leak is increased and therefore the potential of the grid with reference to the filament is decreased. This decrease in the grid potential causes a decrease in the plate current, which explains why detection, by the use of a grid leak and condenser, takes place with a decrease in plate current. It has been assumed in this discussion that all of the radio frequency

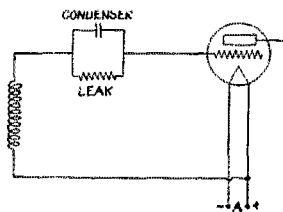

FIG. 2

passes through the grid condenser. This is essentially true due to the very low reactance of the condenser to radio frequency compared to the high resistance leak.

When a modulated signal of the form shown in Fig. 3a is impressed on the grid, the same thing happens to the grid current as outlined above, but the amount of increase in grid current is not the same for each cycle of radio frequency because the amplitude of the radio frequency changes. The grid current which is produced by the modulated radio frequency is

\*234 Linden Ave., Ithaca, New York.

shown in Fig. 3b which illustrates the greater increase in grid current. The average value of grid current at any instant is given by the current wave shown in Fig. 3c. This wave has the same shape as the audio frequency wave which was used to modulate the radio frequency at the transmitting station, excepting that it has been distorted somewhat by the addition of a small amount of even harmonics introduced by the curvature of the grid characteristic.<sup>1</sup> If it is assumed for the time being that all of this audio frequency component of the grid current must flow through the grid leak, because of the very high reactance of the grid condenser to audio frequency, it will cause a voltage drop across the grid leak which will vary directly as the current shown in Fig. 3c. Therefore, the actual potential of the grid changes at an audio frequency in a like manner. It is this change in grid potential at an audio frequency that produces a corresponding variation in plate current. By referring to the plate-current grid-voltage curve Fig. 4, taken at a plate potential of 45 volts, it is easily seen that at the positive grid potentials where the tube is working, the curve is very nearly a straight line and therefore any change in grid potential will produce a corresponding change in plate current without appreciable distortion. The magnitude of the change in plate current

amplifier tube when an audio voltage is impressed on its grid. As will be pointed out later, in plate rectification no such amplification is taking place and therefore the sensitivity of the tube acting as a detector

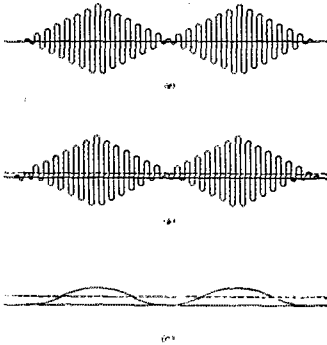

FIG. 3

with a given change of grid potential is determined by the slope of this line, which in turn depends upon the amplification constant and plate resistance of the tube. The slope is always such as to give a larger change in plate current than the actual change in grid voltage, and therefore amplification takes place. This amplification occurs in exactly the same way as in an

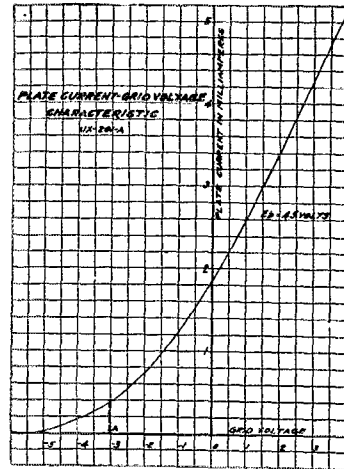

FIG. 4

is much greater when used with a grid leak and condenser than when it is used for plate rectification. However there is much more distortion when the former is used.<sup>2</sup>

### Choosing the Leak and Condenser

It is evident from the preceding discussion that the actual grid potential depends upon the resistance of the grid leak and the potential of the point to which the grid is returned, i. e., the positive or negative filament or through a bias battery. As was mentioned before, these two factors must be adjusted so that the potential of the grid corresponds to the point on the characteristic where the curvature is greatest. It is evident also that the change in grid potential is greater when the resistance of the leak is large, and that greater sensitivity results. However, the potential of the grid return must be adjusted to keep the constant potential of the grid at the correct value. The best results for a UX-201-A are obtained when a grid leak of 2 to 5 megohms is used with the grid returned to the positive filament.

For simplicity, it has thus far been assumed that all of the audio frequency grid current passed through the grid leak. However, this is true for low audio frequencies only. For the higher audio frequencies and their harmonics, there is considerable by-

1. The appearance of a given percentage of 2nd harmonics may be used as an index of the maximum energy which an amplifier should handle.—Tech. Ed.

2. If one has ample energy in the antenna, or a great deal of r. f. amplification in the receiver, the C-battery method of detection has its points.—Tech. Ed.

passing through the condenser, which lowers the impedance and therefore causes less change in grid voltage than the low frequencies. The same effect is produced by increasing the capacity of the condenser and holding the frequency constant. It is then important to make the grid condenser as small as possible without offering an

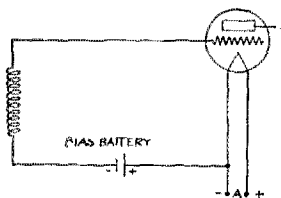

FIG. 5

appreciable reactance to radio frequency because, if this occurs, the actual radio frequency change in grid voltage will be decreased and therefore the rectified current will be decreased. It can also be seen that the resistance of the grid leak should not be increased to too high a value, because this will cause a greater proportion of the audio frequency grid current to pass through the condenser at the higher frequencies. It will be found that the best condenser to use with the grid leak mentioned before is one which has a capacity of .000250 microfarad. Capacities lower than this, decrease the amplitude of the radio frequency e.m.f. impressed on the grid and therefore decrease the output, while higher capacities cause a decrease in output on account of the audio frequency by-passed through the condenser.<sup>3</sup>

The most important point to be noted is that an added source of distortion is introduced by using the grid leak and condenser. This may be termed a frequency distortion. It reduces the sensitivity about 60 per cent at an audio frequency of about 3000 cycles.

### Plate Rectification

In detection by the method known as plate rectification, the grid leak and condenser are not used but a bias battery is used instead. The grid circuit for this method is shown in Fig. 5. It is obvious that there will be no change in the grid potential at an audio frequency—only a change at radio frequency. If the grid is held at a constant potential, A, Fig. 4, by a bias battery, so that the slope of the plate-current grid voltage curve is changing most rapidly, rectification of the plate cur-

rent will take place exactly the same as grid rectification shown in Fig. 3, a, b and c. Thus an audio frequency change in plate current is produced directly by this method without first causing the grid potential to change at an audio frequency.

It was mentioned before that this method was much less sensitive than grid rectification. The reason for this can be brought out by a contrast of the two methods. In plate rectification, the audio change in plate current is produced directly and it is evident that this audio frequency rectified component is very small, but with grid rectification the a. c. component is made to change the grid potential at a corresponding frequency, which causes a change in plate current that is amplified just as if this audio change in grid voltage had been impressed on the grid of an audio amplifier tube.

It is important to note that frequency distortion as produced by the grid leak and condenser is entirely absent in plate rectification. Thus, much better quality can be produced by this method at a sacrifice of sensitivity. An idea of the difference in sensitivity between these two methods may

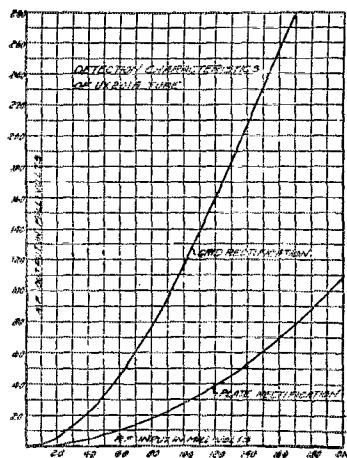

FIG. 6

be had by comparing the input-output curves taken on a UX-201-A tube for the two methods, as shown in Fig. 6.

### Detection with the UX-200-A Tube

A discussion of detection would not be complete without mentioning some of the qualities of the UX-200-A detector. This tube possesses much greater sensitivity than the older types of detector. It owes its high sensitivity to the fact that it makes use of the positive ions of an alkali metal

3. The values are given for the 200-600-meter band. Reference to a previous sentence in the paragraph will show that the best capacity tends to decrease as the frequency increases. This is in line with amateur short-wave practice.—Tech. Ed.

which is distilled into the tube. The actual process of detection is entirely different from that which has been described and it is possible to connect the tube with a grid bias of from -1 to -2.5 volts or with a grid leak of 1 or 2 megohms and a condenser of .000250 microfarad. The grid leak and condenser are recommended because the leak keeps the tube biased correctly. The grid is returned to the negative filament in each case, although when the leak and condenser are used, the return may be connected to the positive side of the filament without much difference in performance. The detection is accompanied by a sort of hissing or rushing noise similar to the familiar noise made by an unmodulated carrier wave in a radio receiver. This hiss is greatly reduced when a carrier wave is impressed on the grid and is therefore not objectionable while signals are being received if not more than two stages of audio amplification are used.

In comparison with other tubes the sensitivity is greatest for small input signals; this can be brought out best by inspection of the input-output curves, Fig. 7, of a UX-200-A and a UX-201-A, with the same values of grid leak and condenser men-

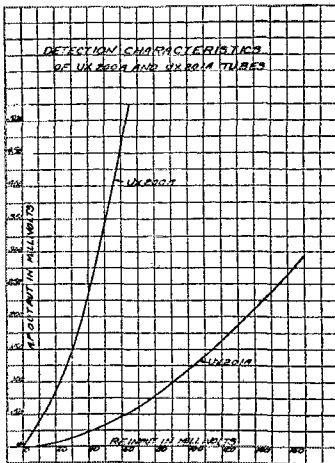

FIG. 7

tioned above. It can be seen that the sensitivity of the UX-200-A is very much greater than that of the UX-201-A for this range of inputs. For very large inputs the difference in sensitivity is not so great in comparison with other tubes. From these curves it may be seen that for weak signals this detector is equivalent to an ordinary high vacuum detector plus one stage of audio amplification.

## When a Guy Wire Breaks

By C. Hoover\*

RECENTLY two of the topmost guy wires on my 50-foot pole snapped. The problem was to put them back without taking down the pole. This is how it was done.

I went to the lumber yard and got four 15-foot lengths of one-inch by two-inch lumber and screwed a hook into the side of each piece near its end. The idea was to fasten the pieces together into a single

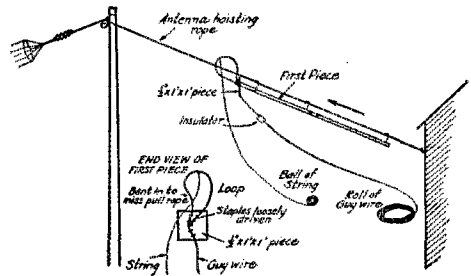

strip and then to push this strip up along the antenna hoisting rope from which it would hang by means of the hooks. The strip which went up first had to carry the new guy wire which was fastened on to a slanting piece of wood a foot square and half an inch thick. The idea of this slanting piece was to make the loop at the top keep shape and give it a convenient angle to slip over the pole when the string was pulled. The details can be seen in the picture. A string was tied around the loop at the top to pull it over the top of the pole when it was in place. With the first section thus prepared the hoisting rope was pulled out taut and the first section hung on it. Another section was then screwed to this and its hooks put over the pull rope and so on until the whole thing was long enough to reach the top of the pole. The hooks in the strip served as guides to run up the hoisting rope and prevent the strip from buckling. When the loop in the wire was at the top of the pole someone pulled the string which made the loop lasso the pole. The new guy wire thus put in place was pulled tight and the pole strips used to put it up were given a slight jerk to pull out the staple which had purposely been put in lightly. Then the strip was pulled down and taken apart. The thing can be repeated as often as necessary to put up the required number of guys. The whole operation took about one hour at 9AMU. Oh yes, we left the strings dangling, but we will eliminate them by setting fire to them and burning them off. We soaked them in kerosene first, just so we would be able to do that.

\*9AMU, 210 E. State St., Marshalltown, Ia.

# A Floating Beat Note

By F. I. Anderson\*

**T**HE hook-up herewith presented provides an automatic frequency changer for superheterodynes; and at the same time does away with the troublesome double beat, that irritating weakness of the super in bringing in a signal at two points on the oscillating dial.

The oscillator in this case is fixed, and long-wave, its frequency being matched to the transformers chosen.

Referring to the diagram, tube B is the "first detector"; and tube A is a tuned radio frequency stage preceding it. Tube C is the long wave oscillator tuned to the peak of the transformer used.

Tubes A and C are connected in parallel across the loop, the tuned signal dividing between them. The fraction of the signal energy taken by A passes on to the first detector at radio frequency. The fraction of the signal energy taken by C is mixed with the long wave oscillations; therefore the output of C (being the subtrahend of the radio frequency and long wave frequencies) becomes automatically the de-

sired heterodyne obtained by manual tuning in the conventional super. This is passed on to the first detector, B, by the usual pick-up.

ways suggest themselves—a separate local oscillator, or a common feed-back. The quartz crystal suggests a fascinating field of experiment.

This automatic frequency changer may apply to any tuning circuit for long-wave transformer amplification. In achieving its automatic feature and doing away with the troublesome double beat of the super, it sacrifices the inherent selectivity of the tunable oscillator. The floating beat-note system is only as selective as its tuner. For this reason one or more stages of tuned r.f. amplification may advantageously be used ahead of the "first detector".

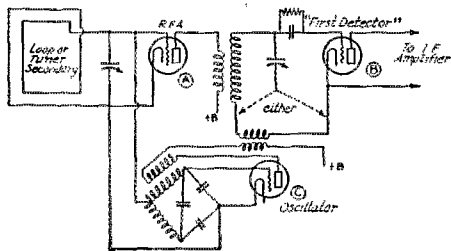

sired heterodyne obtained by manual tuning in the conventional super. This is passed on to the first detector, B, by the usual pick-up.

As an example, let us say the long wave oscillator is set for 50 kilocycles. The tuned signal is, say of 600 kilocycles. The fraction passing through A is handled at radio frequency. The fraction taken by C is heterodyned on the grid of this tube, and becomes 600-50, or 550 Kc. This output is passed on to the first detector, whose output becomes conventionally 600-550, or 50 kilocycles, the frequency desired for amplification via the intermediate frequency transformers.

The capacity-impedance bridge is shown in the diagram as a simple method of mixing the fixed component and the signal frequency without troublesome reaction between tubes A and C. A number of other

## Standard Frequency Schedules O.W.L.S.—S.F.

**T**HE short-wave transmitter of the Gold Medal station (WCCO) at Anoka, Minnesota, has definitely become a part of the system but the "X" call has not been issued (Nov. 2), therefore the station will sign '9WI and 9X-' when sending S. F. schedules.

Additions and Changes			
Dec. 3	Schedule B	9WI-9X—	
Dec. 5	" C	1XM	
Dec. 10	" A	1XM	
Dec. 12	" C	9WI-9X—	
Dec. 17	" A	9WI-9X—	
Dec. 23	" B	1XM	
Dec. 30	" B	9WI-9X—	
Jan. 7	" A	1XM	
Jan. 9	" C	1XM	
Jan. 14	" A	9WI-9X—	
Jan. 16	" C	9WI-9X—	
Jan. 21	" B	1XM	
Jan. 28	" B	9WI-9X—	

The transmissions of 1XM have been and are being checked as stated in the November announcement. The same procedure is anticipated in the case of 9WI-9X—, but is not complete.

### Strays

D. W. Imel, late DX brass pounder on NUMM, the *U.S.S. Litchfield*, is now operating commercially for the Marland Pipe Line Company at Ponca City, Oklahoma. The call is KFE and the wavelength 45 meters (6600 Kcs.). This station communicates regularly with a similar one (KEH) at Panhandle, Texas. The operators are very anxious to determine how well the sigs are reaching out and will appreciate reports of reception of either KEH or KFE. Such reports should be addressed to Imel at KFE.

\*668 Lexington Ave., New York City.



# Checking the Tone and Wavelength of Transmitters

By J. K. Clapp\*

IT seems that many amateurs are not aware that their receiving sets may be used to check up not only on the tone of their transmitters but also on their wavelengths. There are several ways in which these objects may be accomplished, depending upon the receiving system used.

First, let us take the case of the average transmitting amateur, where the station will likely have but one receiver (at least in operation). Suppose the transmitter to be

oscillating circuit, keeping the value of tuning capacitance as high as possible for the desired wavelength; keep the excitation voltage down to reasonable limits by using as few "grid" turns as will give reasonable output; ("grid" turns are those between the center-tap and the grid-tap of the primary coil). Keep the plate load at reasonable values by using plenty of "plate" turns; ("plate" turns are those between the center-tap and the plate-tap of the primary coil). And finally, do not couple the antenna circuit too closely to the transmitter. If the antenna system sways in the wind and produces a wobbly note, detune the antenna circuit by shortening the wavelength of the antenna system until the antenna current is about 80 percent of the possible maximum. Detuning on the "high" side always gives a rougher tone than when the detuning is carried out by making the antenna wavelength less than the oscillator wavelength.

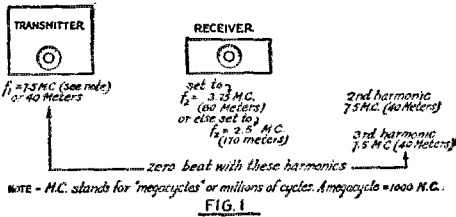

FIG. 1

operating in the 40-meter band. To check up on the tone of the transmitter, it is only necessary to tune the receiver to double, or triple, the wavelength used. See Figure 1. Thus to check the tone for any adjustment of the transmitter within the forty-meter band, the receiver must be capable of adjustment over the range of from 75 to 85.6, or from 112.5 to 128.4 meters. If the transmitter is of low power and not too close to the receiver, it may be possible to obtain a good beat tone with the transmitter frequency, when the receiver is tuned to the double wavelength. If the transmitter is too close to the receiver it will be necessary to use the triple wave in order that a clear beat may be obtained. If difficulty is still encountered in obtaining a clear beat tone, in stations where a separate receiving antenna is used, it may be necessary to remove the receiving antenna connection from the receiver.

Many operators will be terribly disappointed with the tone which they hear when this method of checking is tried. The advantage lies with them, however, for they can now make any adjustments of the transmitter circuit with full knowledge of what effect these adjustments have on the character of the tone. When using a Hartley oscillator the proper adjustments for a steady note are briefly summarized as follows: Use as few turns as possible in the main os-

Using this method, the character of the note may easily be checked and also the steadiness of the transmitter frequency. The shifts of frequency with keying (key chirps) may be detected and also the slow drift due to the tube warming up after the plate load is thrown on. In unstabilized or

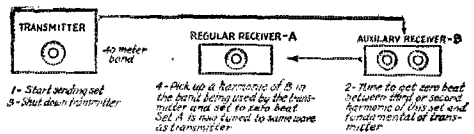

FIG. 2 FINDING THE TRANSMITTER WAVE

non-crystal transmitters, there is always a frequency drift when the transmitter is first started. This drift is worse when the tube is started cold, and is appreciably less when the filament has been running for some time before the plate load is thrown on. Upon commencing keying, the heating of the tube elements, due to the flow of plate current, will cause a shift in frequency, which continues until the elements have reached their new steady temperature. Continued transmitting, at a uniform speed, will then take place with very constant frequency, but a slight shift will result from change of speed in transmission, as the tube elements then assume a new steady temperature.

To obtain a knowledge of just what wavelength is being used on the transmitter, two

\*Instructor, Communication Div., Electrical Engineering Department, Massachusetts Institute of Technology, Cambridge, Massachusetts.

receiving sets are required, or one receiving set and a tube-driven wavemeter. One of the receivers is tuned to double or triple the wavelength of the transmitter, as described above. The transmitter is then shut down and the usual receiving set is used to pick up the second or third harmonic of the one used for listening to the transmitter. The beat tone heard through the regular receiver will be found at the exact point in the band where the transmitter is working. The process is shown by Fig. 2. If, as often happens, the transmitter is found to be adjusted very close to the wavelength of some of the American or foreign commercial stations, operating within the American ama-

indication. The ostensible purpose of a convention is to give the hams an opportunity of improving their minds by listening to talks by men of justified reputation in the art of radio. That purpose was amply met in the case of the Pacific Division Convention. But when all is said and done, we all know that the magnet that draws hams to conventions is that indescribable spirit of fellowship that makes one ham long to meet face to face the fellows with whom he has been conversing over the air.

Meetings were addressed by Dr. Kolster, Dr. Taskar, Gerald Best, D. P. McGowan, A. H. Babcock, A. A. Hebert of A. R. R. L. Headquarters, and others. A traffic meeting developed the usual amount of heated argument. The banquet that took place the second night was attended by some 250 diners. It was the noisiest success that ever came off on the West Coast.

The convention was served throughout by a thousand-watt transmitter kindly loaned and intalled by Ralph Heintz, of San Francisco. This set attracted more attention than any other one feature of the Convention. It was of the tuned grid and plate variety and the most beautiful job ever exhibited to hamdom. At three o'clock the second morning, voice was put into the Philippines and elicited a report of R-7.

Every holder of a Convention ticket had a chance at the 2-Kw. water-cooled tube made (*made*, we said) and donated by 6RW and 6EX. This was won by one of the San Jose crowd.

Among the hams who came from without the district were 7IT and 7WU, well-known in this and many other climes. Wayne Easley, 5AQW, and his brother drove all the way from Oklahoma. These two boys, quiet-spoken but real workers, were a tower of strength. The way they applied their wordless energy in helping Ralph Heintz (6XBB), 6RW and 6EX to get the big transmitter with its remote control hooked up, was worth going a long way to observe. The tall figure of Don Wallace, ex9ZT, now 6AM, was always the center of an admiring bunch.

A great deal of praise is due the members of the Santa Clara County Radio Association and its president, Frank Qument, who worked nearly a year in preparation for this fine affair. The results certainly justified their efforts, and every ham went away with the feeling that here was a convention that *was* a convention.

At the banquet the question of the location of next year's convention was discussed, and the concensus of opinion favored San Diego.

—Clair Foster, 6HM



FIG 3—SETTING THE TRANSMITTER ON A "HOLE" IN THE INTERFERENCE WHICH WAS LOCATED BY MEANS OF THE RECEIVER A.

teur bands, this method of checking the transmitter wavelength will make it evident and will account for the poor DX obtained when trying to compete with several antenna kilowatts, though they may be 3000 miles away.

The transmitter may be adjusted to transmit within a very few thousand cycles of a given frequency in the band by reversing the process outlined in the previous paragraph. (See Fig. 3.) The regular receiving set is first adjusted to the wavelength at which it is desired to operate the transmitter; the auxiliary receiver, or tube wavemeter, is then adjusted to the double or triple wave. The transmitter circuits are then slowly adjusted until beat note is picked up by the auxiliary receiver. When this beat is heard, the transmitter has been adjusted to operate as desired within the band. In this manner it is possible to quickly adjust the transmitter so as to place it in operation in a "hole" in the screen of interference existing in the 40-meter band, or change the transmitter so as to place it in operation in amount, so as to just avoid an audible beating with any transmitter which may be causing interference at the time.

## Pacific Division Convention

THE Pacific Division Convention, held at San Jose, Calif., October 15, 16 and 17, was a highly successful gathering—if the exuberance of some 200-odd hams is any

# The Relative Importance of Losses In Radio Receiving Systems

By William W. Harper\*

**K**ARL HASSEL<sup>1</sup> wrote an article<sup>2</sup> a number of years ago pointing out the feasibility of loss reduction in receiving equipment. His suggestions were sound and well taken. Sensationalism in merchandising and advertising saw an excellent opportunity to capitalize his view point and it was not long before every radio component unexpectedly became "low loss".

The public reaction which naturally followed brought forth an interpretation of the subject deviating slightly from the original conception. The popular reasoning assumed that if "low loss" design was BETTER, then "no loss" design must be BEST. The gradual infiltration of this process of thought made the "low loss" idea a dominating factor in the radio industry. After all, what can be more powerful and far-reaching than the way men think?

Mr. Hassel neglected to say anything in his article in favor of the presence of losses in receiving systems. At the time he wrote, the work which had been done had not definitely disclosed the exact significance of losses. Since that time a more profound understanding has been reached and it is realized that losses may be too small as well as too large. The question then arises as to what will constitute an optimum condition.

This article has been prepared to fulfill the request of Mr. Kruse for a treatment of the subject of inductance standardization. It is contended by many that a standard of coil efficiency is needed. An accepted numerical system for rating the merit of coils may have much in its favor for research purposes, but from a practical and commercial standpoint it may easily lead to even greater chaos. As already suggested, if losses have a lower limiting value, and an optimum must be reached, any numerical merit system with a loss magnitude basis would be almost futile. The percentage of loss in an inductance or other component is of value from a purely scientific viewpoint, but carrying the idea to the popular field is seemingly fallacious, inasmuch as the laity will always expect the most efficient component to give the greatest results with total disregard of the necessity of coordination to the remainder of the system.

It is the particular aim of this manuscript to call attention to certain discrepancies and misconceptions relative to efficiency factors associated with receiving apparatus. It may be that, in so doing, something good can be said for losses and at least it may be helpful to show that ohmLESS components are not always required to assemble a really worthwhile radio receiver.

In general, the ideas expressed herein are applicable to both short wave and broad-

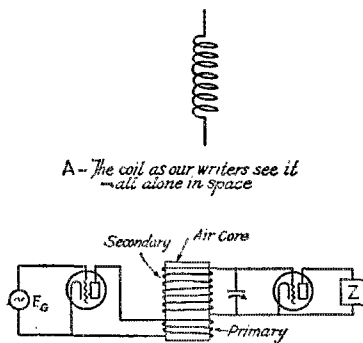

FIG. 1

cast systems. The instances cited, however, will have particular relationship to broadcast receivers.

First, let us confess a common error which we have all made for some time. When attention is directed to a radio inductance so many of us invariably think of it as a COIL of wire in free space—a dissociated member. (Fig. 1) A radio COIL is never operated in that manner. It must have associations. Rarely is it found in practice to be operating in any other capacity than as a transformer. Then why do we persist in calling it a coil and go into a spell of mania upon finding it has some distributed capacity and a few ohms of resistance? Close adherence to the phraseology set forth by the Committee on Standardization of the Institute of Radio Engineers will do much to save us from further confusion.

Rather than speak of COILS let us designate them as TRANSFORMERS in accord with electrical parlance. We may indicate also whether they are resonant or non-resonant and the intended frequency band. Then we may look upon the resistance and

\*Consulting Engineer, 161 East Erie St. Chicago, Ill.

1. Chicago Radio Laboratory & Zenith Radio Corporation, Chicago.

2. QST for December 1923.

power factor of the windings as being more of a sign of the adaptability of the device to various systems and feel much less discomfort over the waste of a few microwatts of energy which may be required in order to attain a certain perfection of results. The physical conception incident to this viewpoint is shown graphically in Figure 1.

Proceeding, we arrive at the typical case of an innocent B.C.L. who has just purchased a new set of resonant high frequency transformers (COILS) for his home constructed receiver. Let us assume that they are actually much more efficient than the transformers he has previously used. A substitution is made. He is positive of increased signal strength and greatly superior results. (The "coils" are labeled "100% LOSS-LESS". Why shouldn't he have good anticipations?) Any of a number of things may happen, all of which are likely to make his receiver operate much worse than it did before. The primaries of the new transformers may be too large or too small. The great reduction in losses may give rise to increased stage coupling and uncontrollable oscillation. Briefly, it is expecting too much to predict how well a receiving system will function with a certain "coil" included in the system from a mere knowledge of the efficiency of the coil with respect to its energy losses. These ideas are expressed graphically in Figure 3.

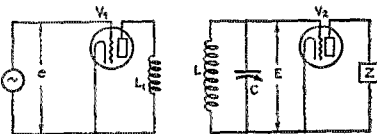

FIG. 2

Consideration of the problem from a more technical angle may make clear why this statement is true. In Figure 1 is shown the unforbidden COIL L. This "coil" has two power factors. The writer, as a matter of personal convention, prefers to name them the "Natural" and "Operational" power factors. The natural power factor is determined on the measuring bench independent of any associated apparatus, excepting of course, the resonating condenser, C. The natural power factor is equal to  $R/\omega L$  and the lower the mean ordinate of this factor plotted against the particular frequency spectrum the lower is the energy loss in the coil. (It is generally accepted that the loss is practically localized in the inductance and excepting in rare cases is there any appreciable loss in the condenser.) The natural power factor or its equivalent is useful in investigational work relating to the losses in various types of inductances. The operational power factor is that which

the coil assumes when associated (Fig. 2) with its primary  $L_1$  and the tubes  $V_1$  and  $V_2$ . The primary, along with the output impedance of the tube  $V_1$  acts in such manner as to couple resistance into the coil L. In this way the natural power factor  $R/\omega L$  increases to its operating value. It has been shown<sup>3</sup> that  $R/\omega L$  is approximately doubled when the primary  $L_1$  is adjusted for optimum voltage gain. Such an increase of the power factor to this operating value (due to the coupling to the preceding output circuit of  $V_1$ ) is necessary and desirable up to this point of optimum voltage gain. Further increase in operational power factor results in reduced voltage gain  $E/e$  and in reduction of selectivity.

The input impedance of the tube  $V_2$  may also appreciably affect the operational power factor of L. The input impedance of  $V_2$  depends, of course, upon the output load Z. Its effect and value, therefore, cannot be foretold without exact knowledge of this load. It is obvious that the use of the natural power factor or its equivalent as an index of ultimate operating results can hardly be expected to preclude the great variety of conditions met with in practical application.

The operational power factor may be determined experimentally by making measurements of the operating values of resistance and inductance. In engineering practice it is more usual to make a direct measurement of the voltage gain and band-pass (selectivity) since they are the factors which must receive ultimate consideration. This procedure, of course can be carried into effect only in the engineering laboratory, and the amateur experimenter rarely has facilities enabling him to select some manufactured transformer to harmonize with his system.

### An Illustration

As an illustration, assume that we depend upon the natural power factor to tell us what results may be expected. Selecting two "coils" (Fig. 3) at random we find one with an average natural power factor of .4% and the other with .6%. We conclude that the .4% coil will give superior results when used in a receiving system. The primaries associated with the two coils are however widely divergent in character, so the condition may occur that the operational power factor of the .4% coil will be entirely unfavorable for satisfactory results. With  $L_1$  very small the voltage gain  $E/e$  in the net-work will be low and if  $L_1$  is too large the band pass may be incorrect.

Furthermore, the .4% coil may be included in a system in which the load at Z will have incorrect proportions. On the other hand, the .6% coil operating in a system

3. Friis & Jensen, Bell Tech Journal, April, 1924.

where the input impedance of  $V_1$  is correctly fixed by the load  $Z$  will give entirely satisfactory conditions for reception. Other factors, such as oscillation control in non-compensated systems, the various effects of shielding, etc., will have further bearing on the situation. All of these things are shown graphically in Fig. 3.

**Multi-Stage Effects**

A multi-tube resonant amplifier system used for radiophone reception and having a high degree of "stage selectivity" is apt to produce extreme side band distortion if the circuit power factors are not maintained consistent with good reproduction. In one instance, a well-known manufacturer deliberately added losses to the successive circuits in order to overcome this difficulty.

In this connection we are forced to realize that in broadcast reception the operational power factor for proper receiving conditions must be a function of the number of stages in a multi-stage amplifier. As the number of stages increases the operational power factor of each stage must also increase in order to give proper fidelity of reproduction. A system comprising a number of stages may function properly with losses in the various resonant circuits greatly in excess to that permissible in a system employing a lesser number of stages. Transformers having secondaries with comparatively high natural power factors may, therefore, be used with satisfaction in a multi-tube amplifier, while in a single amplifier system they would be entirely unsuitable.

The practice of permitting the increase in operational power factor due to the coupling to the preceding plate circuit to give suitable band pass in a multi-stage system is convenient and practical as long as the stability of the amplifier is not reduced. In many cases, where shielding is ineffective, this practice cannot be followed and the use of a high natural power factor must be resorted to. In other words, it is of greatest importance to make sure that the tubes selected will have electrical characteristics suitable for the circuit in which they are expected to operate. As an example, a circuit intended for tubes having a low amplification factor will not function properly when high amplification factor tubes are used, even though the latter tubes may have a much higher figure of merit.

**C. W. Work**

In cases where a very restricted band pass is desirable, as for instance in telegraphic communication, a greater number of stages with slightly less gain per stage would be feasible. It is very unlikely under these conditions that the losses in the individual stages would be too low to give satisfactory tone reproduction.

**Standardization**

The adoption of a numerical merit system for components, which will enable the direct prediction as to ultimate results, seemingly must await other standardizations which are necessarily precedent.

Standardization of transformers for compensated systems will depend generally on

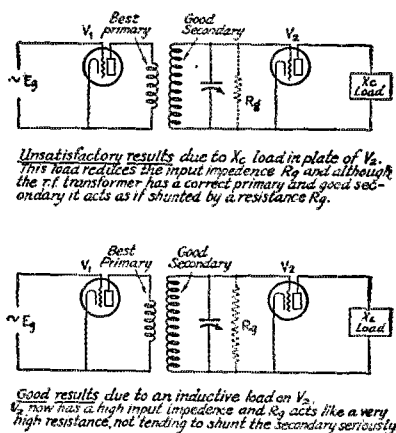
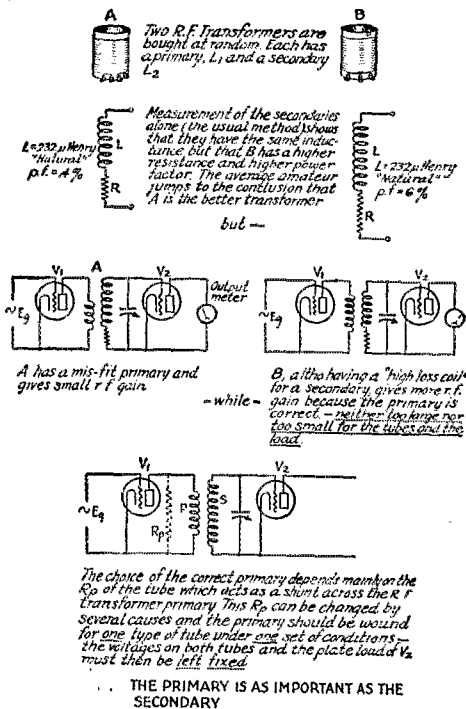

FIG. 3—THE EFFECT OF PLATE LOAD

accepted specifications for vacuum tubes, pertaining in particular to well defined limits for input and output impedances. Further

information will be essential, as well, on the ratio of pick-up factor to over-all receiver gain. That is, do we want an abundance of energy pick-up (large antenna) combined with low receiver gain or do we want low pick-up with high gain? Matters of this kind have direct bearing upon transformer specifications.

Transformation standardization for uncompensated systems will be even more involved due to the stage coupling. The optimum transformer specifications for a loss-stabilized system have never been even partially established to the writer's knowledge.

Mr. S. Butterworth, in the British publication, *Experimental Wireless and The Wireless Engineer*, looks upon the situation from a more pleasant angle. He proposes a numerical merit system for inductance coils involving a term which he calls the "Intensity Factor." This factor, according to his view of the subject, will enable an opinion to be made in advance as to the relative sound intensities to be encountered. It is not clear, just how the obstacles to such a plan, as already outlined, can be surmounted.

Dr. A. Hoyt Taylor, in commenting on losses in short wave receivers not long ago, made a statement to the effect that while average precautions were taken to minimize losses in equipment designed at the Naval Laboratory, they were mainly concerned about whether or not the system oscillated over the desired band, and if it did, no further remorse was felt for those ohms which might have been unnecessarily present.

The writer regards the situation from a very apathetic viewpoint. Rather than be swept away by the human desire to have the best and most efficient of everything, it seems more logical to accept that which is economically and commercially most suitable to meet the requirements at hand. The use of the natural power factor or a figure of merit such as  $\omega L/R$ , as a basic reference index is sufficient for engineering practice. The real need seems to be in deciding upon a standard method of labeling a product with respect to its electrical characteristics and it is not essential that this indication carry with it any knowledge of the quality of results to expect.

This same reasoning can be directly applied to all components as well as transformers. As an example, the Figure of

Merit of a vacuum tube is  $\mu / \sqrt{R_p}$ . This

is an index of the inherent capabilities of the tube. The novice infers that the greater the figure of merit of the tubes he uses the

better his results will be, but he must realize that the tubes he uses must not have capabilities greater than his receiver can tolerate.

The laity, not being thoroughly familiar with the various technicalities, cannot expect too much of a young industry. If they will bear in mind that good reception is the real thing sought for and abandon the attempt to locate some OHM-LESS wonder, time will no doubt smooth out the complications which now exist.

It may be that to meet certain requirements of good results transformers having high secondary power factors are necessary. Obviously they should therefore be used in spite of the fact that other transformers having much lower energy losses are available.

## Kenneth Cantin

With the deepest regret, it is our duty to announce the death of Kenneth Cantin of hu6TQ, Section Communication Manager of Hawaiian Section. Giving unstintingly of his time and energy to A. R. R. L. work in Hawaii, he soon became the life and moving spirit of the Hawaiian Section. He had a sweetness of disposition and a charm of manner that permeated all dealings with him to the extent that those who knew him only through radio or through correspondence express the thought that a dear friend has been lost. The Hawaiian Section and all others in amateur radio will miss him.

## Strays

The Burgess Battery Company has prepared a 48-page log for radio amateurs. The log includes the Burgess Radio Distance Table, International Intermediates and the "R" signal abbreviations. Amateurs can obtain these logs by writing to QRM Department, Burgess Battery Company, Madison, Wisconsin. Logs can be obtained by addressing radiograms to 9EK-9XH only if the complete name and address of the sender are included. Better get yours right now before the supply is no more.

# Another Article on Getting into the Sending Game

By W. R. Kiefer\*

I AM writing this with the belief that if the beginner were shown just how to build some of the apparatus that costs real money, there would be more newcomers. Of course, it has been done before, and in *QST* at that, but there are always new beginners so I am going to try to show you how simple it is to build some of your own parts.

This story isn't about the theory, nor about circuits. You are supposed to have dug that out and to be all ready to build the set.<sup>1</sup> A look at the diagram will show that we intend to use the Hartley circuit. Let's go!

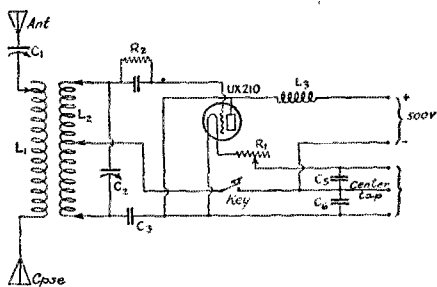

FIG. 1. THE HARTLEY CIRCUIT PRIMARY, COUPLED INDUCTIVELY—WHICH MEANS MAGNETICALLY, TO THE ANTENNA CIRCUIT

If one wants to use two additional clips on the primary coil L2 the output of the set can be improved a bit though that adjustment becomes more complicated. C1 and C2 are good receiving variable condensers of 250 picofarads (.0025 microfarads) capacity.

C3, C4, C5, C6. Fixed receiving condensers of about 2000 picofarads (.002 microfarads) capacity or else glass condensers made as shown in Fig. 3.

R1. Rheostat to suit the tube used. If you have an E210 Bradleystat put that in the filament transformer primary (110-volt side) and omit R1.

R2. 5000-ohm gridleak or the "water-leak" described. L1 and L2. Described in the text.

L3. Depends somewhat on the wave. 200 turns of about No. 23 d.c.c. wire on a 2½" or 3" tube will do for 40- and 80-meter work.

The inductances are made of ¼" copper ribbon. Both inductances have 12 turns spaced ¼" apart and 5" in diameter. The copper ribbon is flat wound on the forms,

which are mounted on two glass towel rods. The spacing between these two coils will be 2 inches or more when used with a 7.5-watt tube.

## The Primary

The closed circuit tuning condenser C2 has 11 rotary plates and 12 stationary plates, double spaced. A wire leading from

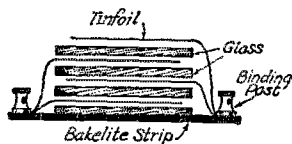

FIG. 2. HOME-MADE CONDENSER

the stator plates of this condenser goes to the same tap on L2 as the grid, while the lead from the condenser rotor goes to the same tap as the plate. This circuit will cover the 80-meter band.

The grid, plate and by-pass condenser can be ordinary receiving condensers of .002-microfarad capacity, but if you want some that won't break down under a good heavy voltage, make them the following way. Cut 12 pieces of glass for each condenser, 2" wide by 5" long, and 12 pieces of tinfoil 1" by 6½". Cut a piece of bakelite 2" by 6½" to be used for the base of the condenser. A 3-16" hole is drilled ½" from each end of the bakelite and a binding post inserted to fasten the foils of each side together. The condenser is made by using first a glass, then a foil, then a glass, etc., until you have six tinfoils projecting on each side with each one separated from the next by a glass. See Fig. 3. The condenser is held together by winding tape tightly around it.

The grid leak can be the usual wire-wound affair a resistance of 5000 ohms, tapped at 2500 ohms. If you can't afford to buy a leak, just take a small wine glass, fill it with water, put the two grid leads about half way in the glass and you have a perfect leak. This type has been used at this station four months with the best of results.

## The Antenna

The antenna has a total length of 75 feet. The counterpoise is 66 feet long. Both are single wires. This combination is for use on the 80-meter band. For 40 meters the

\*SAJR, Box 12, Lattimer Mines, Pa.

1. If you haven't read about these things look them up in the A.R.R.L. Handbook, Ballantine or in the following *QST* articles. "Breaking into Amateur Transmission", p. 8, April, 1926. *QST*, part 2, p. 17, May *QST*; "Adjusting the Transmitter", p. 23, June, 1925, *QST*. The necessary *QST* copies can be ordered from the the Circulation Dept., as usual.—Tech. Ed.

antenna and counterpoise have a total length of 35-feet each. The antenna is 40 feet high and the counterpoise 12 feet from the ground in both cases.

The plate supply isn't described for the good reason that it isn't possible to guess what sort of plate supply you like.<sup>2</sup> The filament transformer and plate transformer (if you use one) should be purchased. It doesn't pay to build them.

Figure 3 shows how just to place your

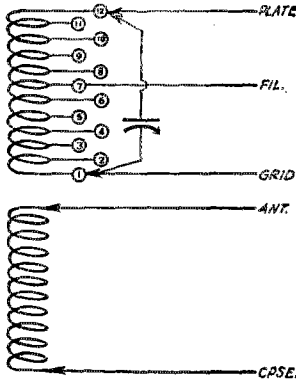

HOW TO PLACE CLIPS ON COILS

FIG. 3. LOCATION OF CLIPS FOR A TRIAL IN THE 80-METER BAND

clips for the first trial at 80 meters. The only thing to be done to go down to 40 meters is to move the C2 condenser leads towards the filament tap four turns, leaving the grid and plate taps the same as for 80 meters. Using a wavemeter the condenser C2 is set at whatever part of the 40- or 80-meter band suits you, but stay in the band.

As to the results to be expected from this transmitter, all I need to say is that anyone who builds it will be more than repaid for his labor.

2. A "flock" of B batteries is good. A rectifier (electrolytic or kenotron) may be made up and a filter used if desired. The UX-216-B rectifier tube is useful or the UX-213 may be used for voltages below 300. The good old UV-216 tube can be bought for less than \$2.00 and will handle more power than necessary.—Tech. Ed.

### A Beautiful Portable Set

ON her recent trip to Europe, Miss Elizabeth M. Zandonini of 3CDQ and of the Radio Section, Bureau of Standards, carried a portable short-wave receiver that deserves description, partly because it is such a nice job and partly because it is actually portable.

The photos show the set removed from the case, which was very little larger than the set but provided space for the head-set. The tubes stay right in the sockets, being protected by the spring construction of

the latter. The set has 5 coils with various numbers of turns. The proper coil for the desired tuning range is plugged into the

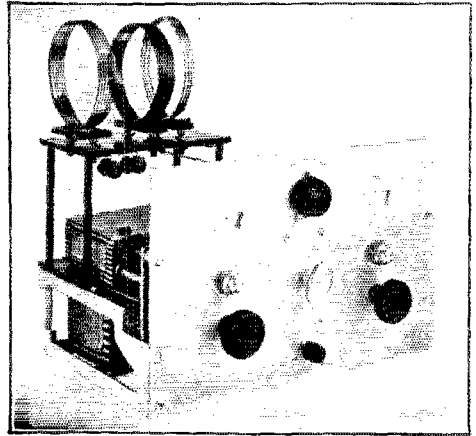

secondary circuit by putting it into the center pair of sockets. Two of the remaining coils are used as antenna coil and tickler respectively. The circuit is the familiar detector-one-step arrangement with the tuning and regeneration both condenser-controlled.

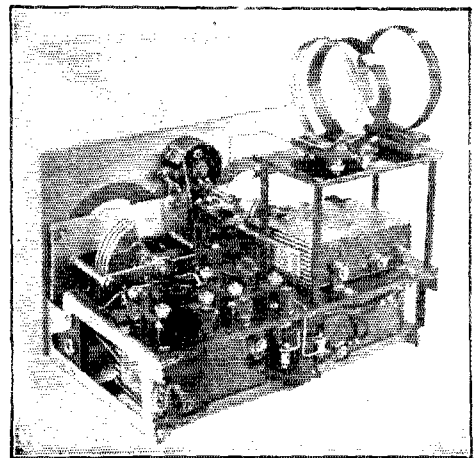

Of the construction, little needs to be said in the presence of the good photos. The unusual features are a rigid metal chassis, an accessible grid leak and the self-contained plate and filament batteries, the latter being provided by the "C" battery just below the coils. The parts are mostly standard and can be recognized easily.

The set is the work of E. B. Duvall, former Atlantic Division Manager and owner of 3DW at Washington, D. C.

—R. S. K.



## Devising a Shielded Receiver Kit

By McMurdo Silver\* and Kendall Clough†

### The General Layout

**M**UCH has been presented in the columns of *QST* and other technical periodicals regarding the shielding of coils and receivers, so that it can hardly be hoped that anything radically new might be presented on this subject in a theoretical light. It is hoped, however, that the following treatment of the method used in putting a shielded receiver kit through the experimental stages will be of interest.

For several reasons it was deemed best to employ two tuning controls rather than a

the remaining adjustment would control the remainder of the radio frequency amplifier stages, as well as the detector input circuit. Inasmuch as three tuned r.f. stages were deemed necessary to meet the present-day requirements, it is recognized that four tuning condensers are necessary, three of which are mechanically grouped and operated by one dial. From this point on, the tuning problem is simply one of producing sufficiently uniform condensers and coils, and connecting the condensers mechanically in such a way that no undesirable variations will be experienced.

### The Gang Condenser

In a three-stage receiver the individual stages may be made sufficiently broad by proper transformer design so that slight discrepancies in the condenser capacities are not noticeable; this can be done without impairing the over-all selectivity of the receiver materially. Previous experience indicated that it would be perfectly possible to build a condenser of 350 picofarads' capacity commercially with sufficiently small variations to be practical in a receiver of this type. Electrically the condenser construction involves no other problem except the determination of plate shape. The one chosen is a compromise between straight frequency line and straight capacity line variation. The resultant frequency-dial

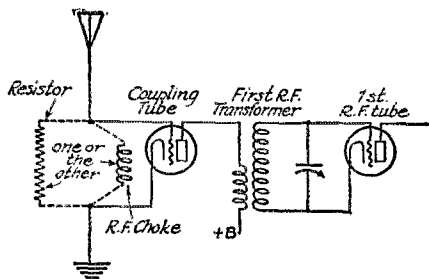
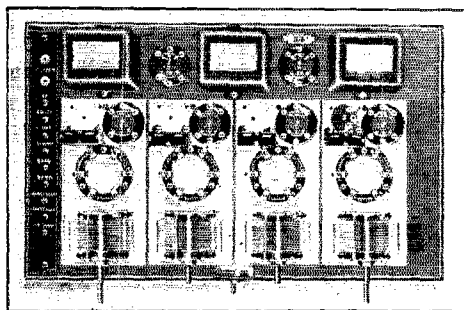

FIG. 1. THE "COUPLING TUBE" METHOD OF SECURING SINGLE-CONTROL TUNING

single adjustment, since single control systems require that certain features be provided for the compensation of different antenna capacities, thereby complicating the constructor's efforts and at the same time not being readily adaptable to symmetrical panel design. One of the simplest methods of preventing variations in antenna characteristics from reacting upon the tuning of the input circuit of a receiver is to add a "coupling tube" between antenna and the first r.f. transformers. This input tube has its grid circuit connected across a non-resonant choke coil as shown in Fig. 1, or more simply, across a resistance. Thus the first transformer has substantially the same primary load as have all other transformers and as the secondary loads may be assumed to be similar, all stages might be tuned by a single control dial.

In the design under consideration, it was decided not to use an extra tube for the doubtful advantage of one tuning control, but rather to employ two manual adjustments, one controlling the first tuned circuit fed by the antenna and ground system, while



THE UNWIRED LAYOUT WITH THE SHIELDS REMOVED

Note that the bypass condensers are inside the stage shields.

setting curve (shown in Fig. 2) provides quite uniform spacing of all broadcast channels up to 350 meters, and from there on a desirable flattening out, resulting in an easier separation of the more powerful stations. Mechanically, it was found necessary

\* McMurdo Silver, President, Silver-Marshall, Inc., 846 West Jackson Blvd., Chicago.

† Kendall Clough, Director, Research Laboratories of Chicago, 846 West Jackson Blvd., Chicago.

1. The picofarad is equal to a micro-microfarad.—  
Technical Editor,

to provide, in the first place, a rigid metal frame structure. In order to meet this condition the end plates are made of punched steel which are held together by 3/8" shoulder studs. Die-flattened plates soldered in accurate jigs by means of small lips pro-

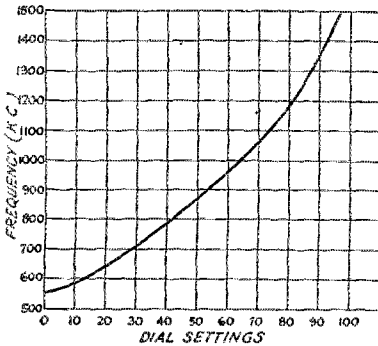

FIG. 2. THE COMPROMISE TUNING CURVE CHOSEN

vide accuracy and rigidity of the assembled rotor and stator. The proper plate spacing was determined by experimental production runs using various plate spacings. With the spacings decided on, condensers can be produced with a uniformity of plus or minus two percent over the entire scale. As ca-

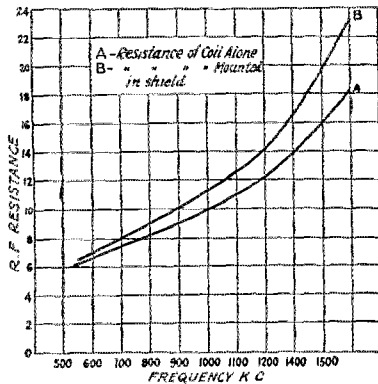

FIG. 3. ELECTRICAL CHARACTERISTICS OF TRANSFORMER SECONDARY CONSIDERED SEPARATELY

capacity enters into the determination of frequency under square root sign, it follows that actual circuit frequency variations<sup>2</sup> of one percent plus or minus at the outside will be experienced.

2. That is the tuned circuit itself—less the tubes in which there may be a small variation, especially if different makes are used.—Technical Editor.

As a means of mechanical linkage between the three condensers, a link motion was chosen for simplicity of manufacture and assembly. Very fortunately it was found entirely feasible to line the condensers up by eye in such a way that a small light space may be seen between the rotor plate assemblies and the points of the stator plates at the zero position of the condensers. The link motion could then be applied and locked fast. Many experimental sets of condensers have been linked in this manner and have proven to be matched with more than the required degree of uniformity when checked electrically.

The R. F. Transformer

The value of the condenser capacity being chosen, it was then necessary to design an r.f. transformer for operation therewith. The fact was continually held in mind that this transformer was to be placed in a shield and hence the final design departs somewhat from the form that it would have taken had it been intended for operation in free (electrical) space. Principally, the classical shape ratio,

$$\frac{\text{diam.}}{\text{length}} = 2.5$$

was departed from in order to produce a more compact field. The shape selected is

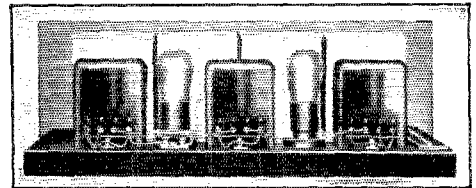

REAR VIEW OF WIRED SET WITH SHIELDS IN PLACE

an hexagonal coil 2 1/4" long and of 2" external diameter wound with 90 turns of No. 26 enameled wire on a ribbed bakelite form. Space is left between turns, the slotting of the coil ribs being 40 to the inch. The low-frequency inductance of the coil is 224 micro-henries. Due to the molded construction of the coil form it has been found perfectly possible to hold this value as well as the apparent high-frequency inductance to a possible variation of 1/4 of 1 percent.

Fig. 3, curve A, shows the electrical characteristics of the completed coil. Fig. 4 is the final arrangement of parts in the shield, and the curve B of Fig. 3 indicates the increase in high-frequency resistance caused by the shield. This increase is greater at the higher frequencies, which is a desirable condition in view of the fact that it aids in the control of oscillations.

With the above data available it became possible to compute the r.f. amplifica-

tion available in a single stage from low-frequency measurements. In the early laboratory models, sample transformers were made up with primaries wound close to the bottom of the coil in order to minimize interwinding (inter-stage) capacity. A 35-turn primary wound in this manner produced an amplification curve as shown by the dashed curve in Fig. 5. It was soon realized, however, that another method of construction was desirable, namely to distribute the primary turns over a greater portion of the length of the secondary, winding them on a small former which can be slipped inside the secondary.

With the secondary and primary form decided upon, a family of coils was now operated on, varying the number of primary turns and always spacing the primary winding in such a way that it would cover the entire length of the tubing thus keeping the coupling co-efficient at a high and substantially constant value. A group of curves covering various primaries is shown

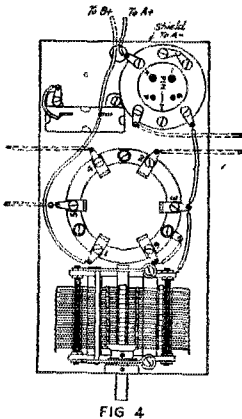

in Fig. 5. It will be seen that as the number of turns is increased beyond 35, the amplification begins to suffer, due to two effects: first, that the equivalent impedance of the tuned coupler is departing from the value of the tube impedance very rapidly, and second, the resistance of the secondary circuit is being greatly increased by the presence of the primary circuit, thereby decreasing the current flowing in the secondary under the stimulus of the e.m.f. induced by the primary. It also so happens that the 35-turn winding represents the maximum coupling possible without producing unnecessarily broad stages, also due to presence of the primary circuit increasing the apparent secondary resistance.

**Stabilization**

Naturally, in embodying transformers with a high co-efficient of coupling in the

receiver design, a considerable amount of difficulty was experienced with self-oscillation. This was overcome in three ways; first, by the shielding; second, by the use of a grid resistance in every stage except the detector, as shown in Fig. 6, and last, by means of a small winding at the base of the

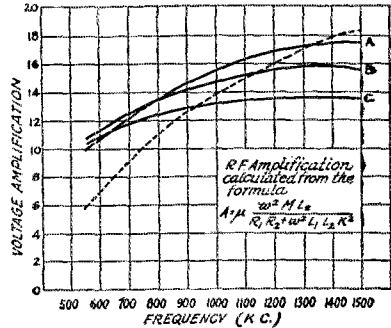

FIG. 5. CALCULATED AMPLIFICATION FOR VARIOUS PRIMARIES USED WITH THE SAME SECONDARY

In the formula,

- R1 is the plate resistance (10,000 ohms.)
- R2 is the secondary resistance, taken from Fig. 3.
- L1 is the primary inductance, measured at l.f.
- L2 is the secondary inductance measured at l.f.
- K is the coefficient of coupling.

Curve A is for the 35 turn distributed primary with which, L1 is 27 microhenry, L2 224 microhenry and M 52, 5 microhenry.

Curve B is for the 50 turn distributed primary with which L1 is 55.2 microhenry, L2 is 224 microhenry and M is 75 microhenry.

Curve C is for the 65 turn distributed primary with which L1 is 93.2 microhenry, L2 224 microhenries and M 97.5.

The dashed curve is for the lumped 35 turn primary first discussed. For the smooth curves the primary is wound on a 1 1/2" tube slipped inside the secondary form. The reversed tickler mentioned later consists of 5 turns of small wire wound on the secondary form just below the filament end of the secondary.

secondary coil connected in series with the succeeding primary and wound in such a direction as to oppose oscillation. The stabilization of the first stage is a separate problem, the above applying only to the following stages and the detector.

In practice, the tendency of the receiver without a stabilizing arrangement would be to oscillate as the wavelength is decreased. Without considering the reasons, the obvious method of overcoming this undesirable feature is to provide a compensating means which will affect the circuits in an exactly opposite and proportional manner. The series grid resistance of two-hundred ohms each ("R", Fig. 6) are somewhat inductive, and their impedance increases with increasing frequency, providing a portion of the action required. (They are outside the oscillating circuits, so do not effect the

circuit sharpness.) The small reversed tickler windings function as do the transformers themselves—their coupling becomes more effective with increasing frequency. Thus the effect of these two stabilizing means is additive in a sense opposite to that

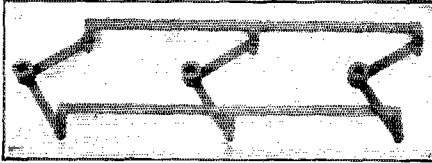

THE LINK MOTION CONTROL ON THE CONDENSERS

of the oscillation tendency in a given stage. The individual stage shields prevent serious reaction between stages. The final net result is an amplifier which is almost uniformly sensitive over the entire frequency range covered.

#### The Antenna Stage

Due to the "loading effect" of various antennas it was found entirely desirable to be able to control the inherent oscillation tendencies of the first stage manually. This is accomplished in a rather unusual manner by means of a potentiometer (as shown in Fig. 6), which serves simultaneously to con-

ly. This method of control has been found considerably more effective than a simple resistance in the plate circuit, due to the fact that under all adjustments of this control the primary of the first radio frequency transformer has a load across its terminals, thus maintaining the other amplifier stages in a stable condition.

In order to accommodate the antenna coupler to various sizes of antennas and also in order to alter the selective characteristics of the receiver at will, two primary taps are provided on the antenna coupler primary, either of which may be chosen at will by a switch on the panel.

#### The Detector

The radio frequency amplifier proper terminates in the detector where rectification is accomplished by means of a "C" battery. Where the sensitivity is ample, this form of rectification is eminently more desirable than grid-condenser-leak rectification; first, because of the better tone quality of which it is capable on large volumes, and secondly, because of its negligible damping effect on the last secondary circuit. The output of the detector terminates in the usual by-pass condenser and an r.f. choke coil, the latter having been found necessary in order to completely isolate the

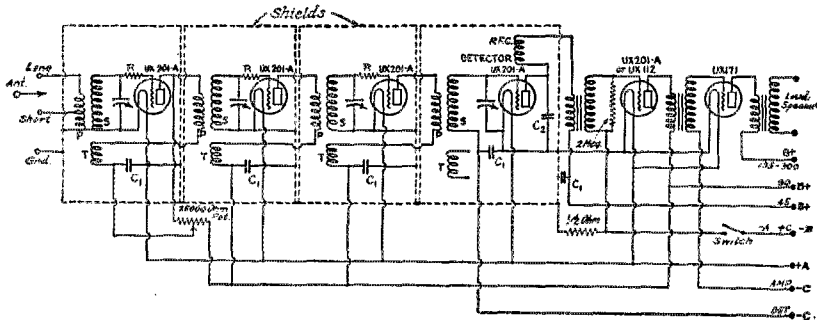

FIG. 6. THE COMPLETE CIRCUIT DIAGRAM

The bypass condensers marked C, are all of 1 microfarad capacity while C<sub>2</sub>, the bypass for the first audio transformer, (connected to detector plate) has a capacity of 2000 picofarads.

control oscillation and as an effective volume control. It will be seen that as the potentiometer advances, resistance is introduced into the plate circuit to effect a reduction in plate voltage on the first tube and that at the same time the portion of the potentiometer in shunt to the primary and tickler windings becomes smaller, thereby suppressing oscillation and ultimately decreasing the volume to almost nothing. In an opposite direction the reverse effects are observed, the stage being allowed to approach the oscillating condition more closely.

8. Two separate shields, even though connected together, are in general more effective than a common shield divided into "rooms" by a partition wall.—Technical Editor.

audio amplifier from any radio frequency advance in the preceding stages.<sup>4</sup>

While the input capacity of the detector tube is lower than that of the r.f. amplifier tubes due to the difference in the nature of the plate circuit load, yet it varies by such a slight amount (using plate circuit rectification) that it is unnecessary to compensate for the difference, though this might easily be done by shunting the tube's input with a small condenser.

#### The Audio End

It is a well-known fact that the pick-up and amplifying equipment as used in the av-

4. Fuzzy audio quality can frequently be corrected by means of such a choke.—Technical Editor.

erage broadcast station does not transmit all frequencies with absolute fidelity. Briefly, it may be said that distortion is introduced, taking the form of a suppression of low frequencies (except in a very few extra good stations). It is further very well-known that it is impossible at the present stage of the art to build loud speakers which will give a uniform response to all frequencies.

Both these conditions tend toward a suppression of low frequencies and accentuation of high frequencies in broadcast reproduction. Therefore, in the amplifier under consideration, an exactly opposite frequency characteristic was decided upon. Thus the amplifier in question gives maximum amplification at 30 cycles with gradually decreasing amplification toward 8000 cycles (the upper limit required for thoroughly satisfactory broadcast transmission).

A further condition, not normally considered, is that (due to the characteristic of the human ear) the energy required to produce a signal of the same *apparent* intensity at 30 cycles is very much greater than that required at, say 300 cycles. Therefore transformers were chosen which are extremely heavy. The core contains approximately  $2\frac{1}{2}$  pounds of silicon steel. The choice of silicon steel as against some special steel of greater permeability is due to the flatter permeability curve of silicon steel at varying inductions such as would be encountered in transformer operation. The secondary distributed capacity was given a value which was found to give the desired frequency characteristic.

In order to keep the plate impedance of the first audio tube as low as possible (to improve low note reproduction) a one-volt grid bias is used. It is obtained from the drop across the filament resistance. The second audio tube is supplied by a regular "C" battery of the rating specified by the tube manufacturers.

### The Mechanical Structure

The mechanical structure is a job for a mechanical engineer and not within the limits of this article. The assembly used in this case consists of a formed and pierced steel chassis (lacquered to prevent rust) carrying all parts. At the front of this chassis are fastened the four aluminum stage shields, each housing an r.f. stage. The audio amplifier is mounted on the chassis behind the r.f. shields, as is evident from the photo. At the left is a terminal strip carrying terminals for all batteries, antenna, ground and tip jacks for a loud-speaker. Both audio stages are always in use to prevent over-loading of the detector tube, the volume being controlled at the input as explained before. A brass front panel serves to conceal the "works" and carry all controls, consisting of the two tuning dials, the

on-off switch, volume control, and short-long antenna switch. No filament rheostat is provided, for it was definitely determined that during the normal useful life of a charged storage battery the fixed ballast resistance provided satisfactory control.

## BOOK REVIEWS

By R. S. Kruse, Technical Editor

*Radio Frequency Measurement*, E. B. Moullin, M. A., A.M.I.E.E., published by Charles Griffin & Co., Ltd., at London and by J. B. Lippincott Co. at Philadelphia. 278 pages, 134 line drawings, price \$10.

From the designer of the Moullin r.f. voltmeter one expects something really worthwhile in the way of a discussion of r.f. measurements. This expectation is fulfilled in *Radio Frequency Measurements*. The book is excellent and every man interested in the experimental side of radio or in the practice of design work will appreciate it as an excellent reference work. The book has what the famous Circular 74 of the Bureau of Standards lacks—the "reduction to practice" of the theories on which laboratory work depends. The reader is not left in mid-air, perched on a theory and afraid to move, for Mr. Moullin has built for him a bridge of practical examples leading to the work in hand.

In many ways this book seems worthy of much more space than this review can give it. We can at least indicate the contents by chapter headings, as follows:

- I. The Valve Generator
- II. Measurement of Potential Difference and Current
- III. Measurement of Frequency
- IV. Measurement of Resistance
- V. Measurement of Capacity
- VI. Measurement of Inductance
- VII. Measurement of Antenna Characteristics
- VIII. Measurement of the Intensity of Radiated Fields
- IX. Miscellaneous Measurements and Notes

Suffice it to say that the contents of the chapters fit the headings.

*Establishment of Radio Standards of Frequency by the Use of a Harmonic Amplifier*, Scientific Paper No. 530 of the Bureau of Standards. By C. B. Joliffe and Grace Hazen. To be obtained from the Superintendent of Documents, Government Printing Office, Washington, D. C., at 10c.

This pamphlet describes the very interesting method which constitutes the latest addition to the family of methods used at the Bureau in establishing frequency standards. Briefly, the scheme is to pass the output of an electrically-operated tuning fork through a series of stages of amplification, each stage picking off a harmonic of the frequency used in the previous stage, thereby gradually increasing the frequency as desired. Comparison is then made between the output frequency and any other device to be calibrated by measuring the difference frequencies with a sonometer.

*Safety Rules for Radio Installation*, Handbook No. 9 of the Bureau of Standards, Department of Commerce to be secured from Superintendent of Documents, Government Printing Office, Washington, D. C. Price 10c. 24 pages.

This is part 5 of the fourth edition of the National Electrical safety code. Anyone having occasion to install radio equipment for himself or others should carry a copy of this book for reference. The rules have been modified materially.

## As Others See Us

By F. Johnson Elser\*

ONCE upon a time there dwelt in a large city a BCL, which is to say a receiving radio amateur. Now this BCL, could recall the days of single circuit tuners and of broadcasting stations that played phonograph records. He had started in with a crystal detector and a 75-ohm telephone receiver and had assembled many sets, even an 8-tube tuned r.f. set that *worked*. Having achieved this height he found that reception began to pall and he began to search for other heights to scale.

In his wanderings he chanced upon a newsstand at which was a copy of *QST* and being in an inquiring state of mind he said to himself, "The price is only two bits and I might run across something worthwhile." Therefore he took the *QST*, but being honest he left a quarter of a dollar with the keeper of the newsstand.

Before his regular evening session of dial-twisting he opened the pages of *QST* and went over them one at a time, missing nothing. He became so interested that he did not listen that night tho there was scheduled the monthly initiation of the "Wild Order of Bulls" at his favorite broadcasting station. As he read it came to him that he had been very foolish to be but a receiving amateur and to neglect this sport of transmission for so many years. "Tomorrow," so he said, "I will buy the parts of a short-wave outfit and likewise an Omnigraph, for now I believe what I have heard, namely that it is more blessed to transmit than to receive."

As the days went by he became more expert in reading the code. First he was able to copy calls and collected them from all districts and from foreign lands; later he began to copy fragments of sentences and then one evening—as it has happened to many of us—he suddenly found himself able to copy sentences. He tuned in a loud station that was sending slowly and said "Now I will copy this man and learn something of benefit to me."

Thereupon he wrote industriously and this is what was on the paper after he finished:

"Yes OM that is a good one but have you heard this? A cat may have 9 lives but a frog croaks every night. Hi, Hi! Sa OM can you tell me where to get some readymade post holes? I have the two by

fours and want to make an 80-foot mast but it is too much work to make the hole for it. Wait a bit I want to make a test with you how does this sound now? Did you get that message o.k.? I mean the one I forgot to number——" and more rubbish of the same sort, all sent double at 10 words per minute. The station finally signed off like this 9XXK 9XXK 9XXK 9XXK 9XXK 9XXK 9XXK 9XXK 9XXK 9XXK 9XXK 9XXK u 8") X". This part of the sending was done with the speed—but not the beauty—of light.

BCL tuned in another station, and then

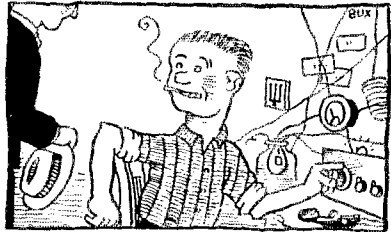

"SO YOU WANTA BE A SENDER DO YUH?"

another but heard little besides the sort of balderdash that 8")X had sent. He gave up and said—"It seems I am going at this thing wrong. I shall look up an amateur who knows how and ask him."

He went to a station he heard of and found the owner sitting before a pile of junk that could hardly be seen for the web of haywire surrounding it. The BCL mentally compared this horror with the beautiful receivers that had been built by his BCL friends and shuddered—but stayed.

The HAM (for he was not a transmitting amateur but a HAM) threw out his chest and said, "So you wanta be a sender do yuh? Well you sure came to the right place buddy; this set of mine is the best in the city. I only use 5 watts but I radiate 3 amperes. I gotta put the tube in oil—the plate gets so hot when I open up."

As they seated themselves before the kitchen table the HAM threw many inconvenient switches and began banging on a key that had a spring so strong that everything on the table jumped from the recoil every time the HAM hit the knob. He called furiously for 10 minutes and then grinned—"There, *that* otta raise them; I got 2000 on the plate." He twisted dials without any result, suddenly

\* 600 M.H. del Pilar, Manila, P. I.

projected his head into the web of hay-wire and grunted, "Darn B-battery lead untwisted again." Wiggling cautiously out of the net he sat down again and sent the same long CQ.

Immediately there was heard a strong smooth signal that called them and with good even sending said to them: "G E O M U R 5 QSS Bad Here QRMV?"

HAM answered, "G E O M RRRRRR O K U R 9 QSB DC QTA QSZ G A A R K".

So the loud station came back at him sending double and carefully repeated what it had said. HAM told him to go ahead with the msg. But while it was being sent HAM had local interference and his feeble mind went astray and he began to wander all over the scale looking for DX. Now he uttered a glad cry, for he heard an English station, and (giving the other station not even a thought) he gave the Englishman a long, long call.

While he was still calling BCL quietly went away, for his heart was heavy and he desired solitude. As he trudged homeward he said to himself, "Why did I ever fall for this bunk about amateur transmission anyway? It is easy to see that they are a flock of dumbbells. I shall have no more to do with them but shall go back and listen to the initiation ceremonies of the 'Order of Wild Bulls.'"

BCL went about thereafter, telling his friends of the matter and causing them to abandon their intentions to try transmission.

Here our whole story would end in gloom and sorrow except that there happened a lucky accident, which was that the officers of the local Transmitter's Club heard of the experience of BCL and called on him and after much argument persuaded him to attend the club and to see some good stations and in the end won him back entirely.

Now the moral of this story seems to be that there are transmitting amateurs and likewise there are HAMS—and these are not the same.

### Strays

Through a typographical error, prices in the Yaxley advertisement on page 51, of the September issue, were transposed. The No. 444 Power Control is five dollars and the No. 445 is six dollars.

We are glad to report that the latest edition (that of June 30, 1926) of *Amateur Radio Stations of the United States* is now available from the Superintendent of Documents, Government Printing Office, Washington, D. C. It is 25c per copy, payable by certified bank check, postal money order or cash, but not postage stamps.

### Strays

The Bureau of Standards announces a celebration of the twenty-fifth anniversary of the Bureau. On Saturday, December 4th the Bureau will keep Open House and a banquet will be given at which the many friends of the Bureau will meet the staff and reminiscences will be exchanged, the achievements of the quarter century reviewed, and present and future work discussed. A group of distinguished guests will attend. The event is of interest to the world of science as well as to the industrial experts who have so closely cooperated with the Bureau in making application of its discoveries and developments in perfecting the measured control of processes. The opportunity to inspect the experimental research facilities of the Bureau will be welcomed by its many friends.

It is suggested by 8BMN that excellent material for vertical pipe antennas can be made from lengths of brass sanitary pipe similar to the type used in milk condensing plants. The pipe is much lighter than iron. It comes in ten-foot lengths. 8BMN uses a 1½-inch piece at the bottom and two 1-inch pieces on top. The pipe is nickel plated.

Eugene Pike of New York City says that if one needs a modulated oscillator for testing purposes, or for use as a driver in balancing neutrodyne, one can be assembled cheaply and quickly by putting the low-voltage side of a bell-ringing transformer, toy train transformer or some similar contrivance, in series with the B battery of an oscillating receiver. This scheme gives a rather low note but it has the advantage of extreme simplicity.

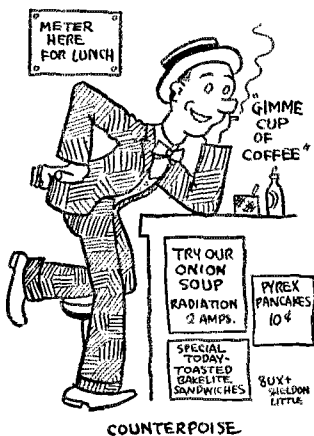

## A Break-In Relay

By M. S. Brainard\*

**T**HE relay here described has been in operation at SLO for seven months and is giving excellent service. As will be seen from the drawings, the relay has two sets of contacts, one for closing the starting current for a motor-generator and for lighting the filaments of the transmitting tubes, and the other for mak-

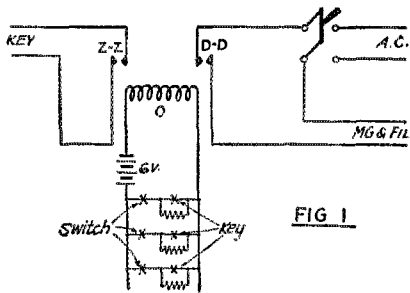

FIG. 1

ing and breaking the keying contacts. The relay itself is operated either by a straight key or a bug connected in series with the solenoid O and 6 volts of battery. The relay will handle a starting current of about 30 amperes at 110 volts on the power end, and 150 m. a. at 700 volts on the key end, and will not stick when properly adjusted. The solenoid draws only 100 milliamperes at 6 volts, so the device can be operated economically from standard No. 6 dry cells.

In Fig. 1 the hook-up for the relay circuit appears. The relay solenoid is represented at O. The two pairs of contacts are D-D and Z-Z. When the switch S.W. (or any one of them) is closed, the current flows through the resistance R and closes the D-D contacts which start the motor-generator. When the key is closed the resistance R is short-circuited and the other pair of contacts Z-Z are pulled up and the oscillatory circuit of the transmitter is completed. The resistances R can be 30-ohm Cutler-Hammer fixed resistance units. Any number of keys and resistances may be connected in parallel, as shown in the diagram, making it possible to have one transmitter to serve a large number of operators, the transmitter being controlled from each man's station through a pair of relay wires, or a single wire working through ground.

The base is shown in Fig. 2. The illustration of Fig. 2 (and all those following) is drawn to half-scale. The dimensions can

be taken directly from the drawings. The base is made of a small piece of bakelite or hard rubber, drilled with holes for binding posts, feet and solenoid core. The feet are terminals from a dry battery, and are held to the base by means of short lengths of No. 8 machine screw which are threaded into the base.

The solenoid core R is a half-inch iron bolt threaded as shown in Fig. 3. A hexagonal nut U, fitting the bolt threads, is filed down so that it will fit beneath the base. On this core are mounted two rectangular pieces of  $\frac{1}{8}$ -inch Swedish iron for pole pieces. In this particular model we used rectangular pieces. If more than two circuits are to be controlled the shape of the pole pieces will have to be changed accordingly. These pieces are S and T of Fig. 3.

From the same piece of Swedish iron the armatures D and Z are to be made. They are drilled according to the plan shown in Fig. 5. Parts F, G and J are made from quarter-inch bakelite drilled and tapped as shown in Fig. 5. The light metal parts are made from brass stock about the thickness

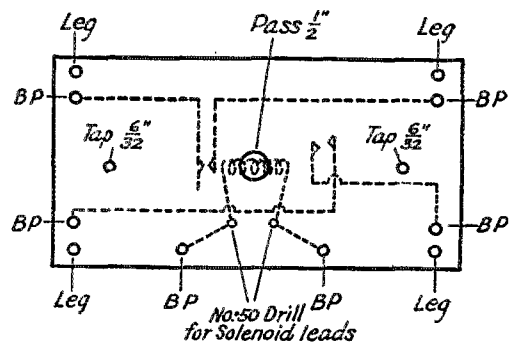

FIG. 2

of variable condenser plates. In fact, such plates were used in the construction of this model. Four pieces are cut for part B and four for part C from this material. The B parts are to be used as "back stops" for the keying armature Z (which carries a pair of Z-Z contacts mounted in the same manner as the D-D contacts on the starting contact armature D of Fig. 4).

The C parts are bolted firmly in place, and act as supports for the pivots N on which the armatures balance. When drilling for the pivots, clamp two of the C parts

\* SLO, 1313 Jefferson Avenue, Toledo, Ohio.



and the armature which these will support, in a vise and drill through both of the C pieces and the armature at the same time, so that the holes will line up properly. We used a No. 50 drill and then broke off the drill and used it for the pivot N. The hole in part B should be drilled so that a

over the core and against parts S and T (Fig. 3) to insulate the windings from the iron.

Part H is made from brass or aluminum stock and seems to be a perfectly satisfactory adjustment device. These pieces also allow one to get the proper spring tension on the armatures. Any typewriter shop can furnish the springs used to hold the armatures back.

It will be noticed that there are two pieces of bakelite a quarter of an inch thick, under the pole at the base end. These pieces raise the whole works a half an inch off the base where they can be seen, and places all parts away from possible trouble.

Some trouble may be experienced in the keying contacts sticking if too large a condenser is used across the contacts. We started with a 1- $\mu$ fd. condenser and passed along down until we found a type 640 Dubilier .01- $\mu$ fd. condenser was amply large to prevent sparking. No condenser is required across the a.c. starting contacts. Proper adjustment of the armatures will assure you that the a.c. starting contacts will close rapidly when the starting switch is closed, and the solenoid will get ample current through the resistance around the key to hold the starting contacts until the

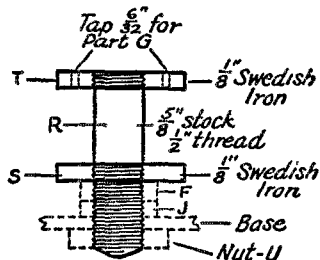

FIG. 3

No. 6 screw fits loosely, and so that this screw can be readily adjusted. The screw K is drawn up tightly to hold the armature the right distance from the pole pieces.

The contacts A are common Ford contacts, of tungsten, and cost about 30 cents

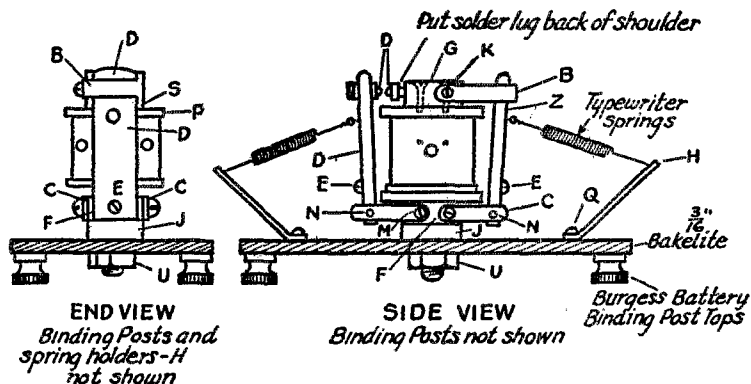

FIG. 4

each. Our first relay had \$14.00 worth of platinum contacts which made one leap for the poles when the current was put on them, and stayed there in fond embrace. A small lug is placed back of each stationary contact, and a pig-tail is attached to each of the screws E (Fig. 4). Then leads are run to the appropriate binding posts on the base.

The solenoid O is wound full of No. 36 s. c. c. or enamelled wire, first being sure that several layers of insulating paper are wound around the core proper, and insulating bushings of the same material placed

switch is opened. When the resistance is short-circuited by the key, the key armature will pick up immediately. The keying contacts can be opened and closed faster than you can send. Listen to it yourself and you can tell how it is working. If the spring on the keying armature (d) is too stiff the keying contacts will work the same as they do when the telegraph key's spring is too stiff, and if this spring is too loose the armature will not return as it should. The correct adjustment for both armatures is secured through the manipu-

lation of the two springs and the back-stop B on the keying (Z) armature. The spring on the Z armature should be quite a bit stiffer than that on the D (m.g.) arma-

faithfully. The current drain being only 100 milliamperes, the device is very economical to operate, and it is one of the handiest things at 8LO.

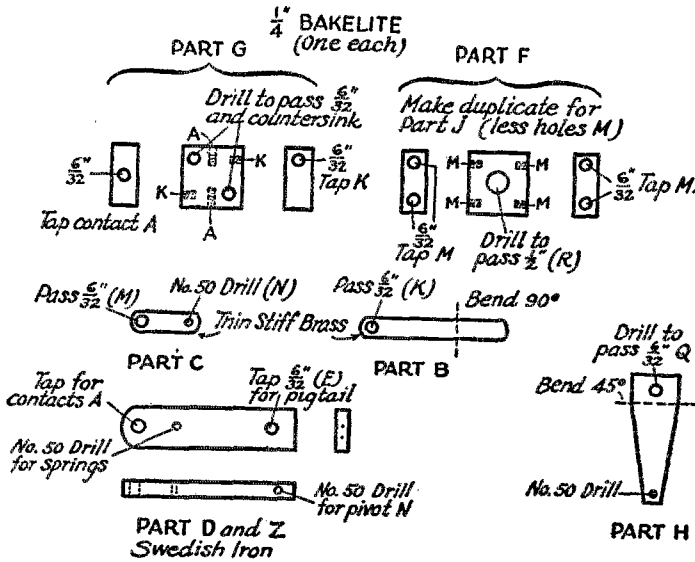

FIG. 5

ture in order that the Z armature will not close when the operating switch is closed. Once the correct setting of the springs and back-stop has been found, the relay will maintain its adjustment indefinitely.

A few words of caution, though. Be sure of the length of screws you put in blocks F and G. By careful work the ends of these screws will be at a safe distance from each other. Be sure to use Swedish iron, as common iron has too much reluctance for such a small core. If the best iron is used it will be possible to use armatures on all four sides of the relay, each armature controlling a different circuit. Our relay has a closed separation of about  $\frac{3}{32}$  inch. This is about right as the armature and pole pieces must be separated about this much or there will be a closed magnetic circuit and the armature will "hang" for a moment. Do not increase the voltage on the solenoid much above six or the keying armature will "spank" the contacts hard enough to knock the contacts out of place.

With the relay at 8LO no one has been found who can make the thing stammer. You can send as fast as you please and the relay will reproduce every action of the key

**Strays**

Another ham has deserted the ranks of the single. On the ninth of September, Miss Viola Elizabeth Mueller and Charles Kolster (2AVG) were married. The Kolsters are at home at Ozone Park, L. I. Congrats, OM.

a5BG urges the U. S. gang to get up toward the upper end of the 40-meter band if unQRMed contact with foreign amateurs is desired. 5BG points out that most of the U. S. 40-meter stations are operating all in a bunch around 38 meters, leaving the field above 38 meters wide open. He says the foreign receiving operators are regularly covering the whole of the 40-meter band. Crawl up, OM.

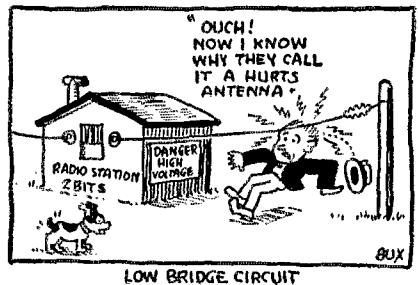

## A Shielded Short-Wave Receiver

By F. J. Marco\*

**R**ECEIVING engineers (and therefore manufacturers) are now rather well converted to the idea that the judicious use of a few sheets of metal can actually do more good than harm in the design of the highly sensitive and selective broadcast receiver of today. However, before describing a shielded *short-wave* re-

tion which persists in spreading all over the dial, sixty cycle induction from the lighting lines feeding the table lamp, and in some cases, on the shorter waves, we have "body-capacity" from the hand of the operator. In addition to this there is the roar of our own transmitter, especially bad when we attempt a "break-in" system. Shielding, carefully used will serve to cure some of these evils in entirety and all of them in part. That makes it very much worth while.

It will be found that a *completely* shielded cabinet is necessary, only the antenna itself being allowed to pick up energy. On broadcast frequencies this is not so important, the pick-up of batteries and phone cords being of small moment. On high-frequency work the batteries *must* be housed and grounded and the phone cords protected by means of R.F. chokes or a grounded, metal-braided covering.<sup>1</sup> This is because the battery's electro-static capacity and the capacity of the operator's body, transmitted to the set thru the phone cords, are fairly respectable antennas for high frequencies and as such are a disturbing element.

By referring to Figure 1., we see the complete receiver which was designed for ex-

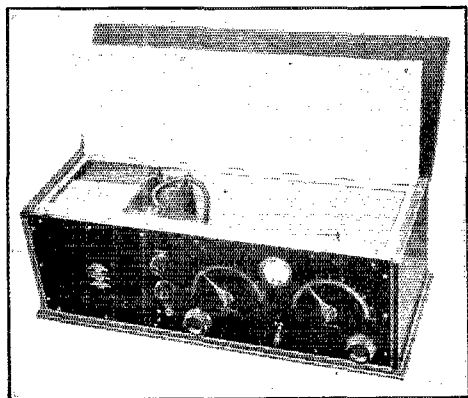

FIGURE 1—THE COMPLETED SET

ceiver, it may perhaps be pertinent to attempt to deduce what may be expected when shielding is used. Complete, perfect low-resistance shielding will confine both electric and magnetic fields, keeping disturbing influences *outside* and self-generated fields *inside* the metal compartment. In multi-stage broadcast receivers this is very important. Interstage coupling (except that existing because of tube capacity and intentional forward coupling) is eliminated. This allows a greater amplification-per-stage and a better filtering action, giving increased selectivity. Oscillation prevention is made easier and individual-stage pick-up is eliminated. This all sounds very well but in the amateur C. W. receiver of the conventional two or three tube regenerative type we have *none* of these problems. There is only *one* tuned stage and no oscillation worries, except when the thing won't. There is no hope of increased selectivity because our one tuned circuit can gain very little by confinement. It may seem from these facts that shielding is a terrible mistake. But wait! We have the power leak, the local broadcasting sta-

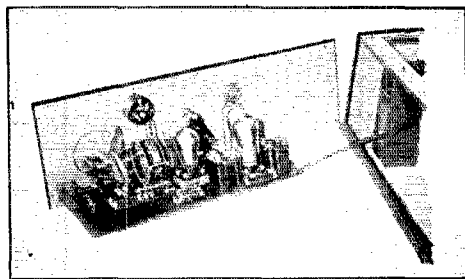

FIGURE 2—SET REMOVED FROM CABINET

perimental purposes for Aero Products, Inc., and is now in daily use at the writer's station, 9ZA. At the extreme left, covered by the blank metal plate, is the storage battery,

1. In many locations the housing of batteries is not essential, the same good effect being gained by merely bypassing them plentifully, which is to say with a 6-10  $\mu$ f condenser. The author's location near WEBB demands abnormal precautions, though other city dwellers may have equally hard luck with stations or power leaks.—Tech. Ed.

\* Consulting Engineer, 5723 Winthrop Ave., Chicago, Experimenters' Section A.R.R.L. and 9ZA.

a six-volt, motorcycle-size Willard. The battery compartment is lead-lined and vented to the outside of the cabinet. Immediately to the rear is an Elkon trickle-charger which is always in operation when the set is not in use. This is also vented to insure sufficient cooling. The next compartment houses two intermediate-size 45-volt Burgess B battery blocks and a 4.5-volt C battery to keep down the audio tube drain. The flexible cable connects all this to the baseboard of the set itself, as can be seen from Fig. 2. The front panel controls are only two—tuning on the right and

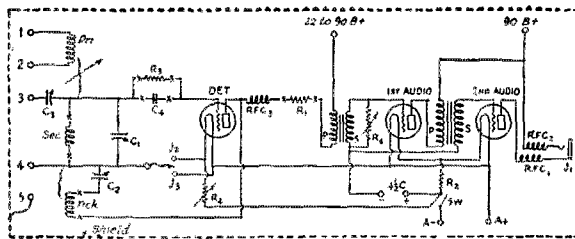

FIGURE 3—THE WIRING DIAGRAM

regeneration on the left. These use the "fish-line" vernier which is a large V-grooved pulley and pointer on the condenser shaft belted with silk fish line to a small driving pulley. This driving pulley is carried by a shaft which can be turned by a large knob. These tuning knobs are placed near the lower edge of the panel. (See Fig. 1) By careful machining and adjustment these verniers can be made to "flow" very easily and make tuning a pleasure.

The telephone key in the lower center is the filament switch, having three positions. When the switch handle is all the way down everything is off. When it is all the way up, both A and B batteries are on and the set is in operation. When the switch is in the center, only the A battery is on. This keeps the tubes warm while transmitting, though nothing is heard in the phones. When one is thru sending, the switch is flipped up and the set works *instantly*, without having to "settle down". This scheme, originally used on the Chicago Radio Laboratory receivers, is a convenience that should be welcomed by every relay man. The meter tells the usual filament voltage and plate-voltage story. The low-voltage side of the meter is connected to the detector filament, the audio tubes having no rheostats but depending on fixed "ballast" resistances. The upper small knob controls the detector rheostat, and the lower controls a variable high resistance (RA in the diagram) shunted across the first audio transformer, acting

as a volume control. The output jack of the last stage is immediately below. Two stages are always used.

Figure 2 shows the inside of the set and some detail of the front shield. The set is practically the standard Aero short wave product as in February QST, with a few refinements that can be seen from the wiring diagram, Fig. 3. Three r.f. chokes are used, each spaced-wound of No. 40 enameled wire on a half inch tube, three inches long. Two of these (RFC1 and RFC2) are in series with the phone jack J1 to keep the phone cords out of the problem, and the other (RFC3) used in the usual manner in the detector plate circuit as a radio-audio filter. In series with this latter choke (RFC3) is placed a set of clips to take a 25,000-ohm resistor (R1) in case this is preferred to the choke coil. Indications are that the choke is desirable. The audio filament ballast R2 is seen at the far right and the sponge cushioning of the detector tube socket is apparent. The tube in the photo has been de-based though that is not essential. The grid-leak and condenser are

both plug-in to facilitate finding the best combination. A 12-megohm leak R3 and a home-made 50-picofarad condenser C4 are used.<sup>2</sup> The grid return lead terminates in a flexible wire and a General Radio spring plug. This plug may be put into a jack J3 connected to the plus side of the A battery or another jack J2 connected to the negative filament. Depending on the tube and the signal strength, one or the other is best. The tuning condenser C1 has a maximum capacity of 140 picofarads and the regeneration control condenser C2 goes to 250 picofarads.<sup>2</sup> Both condensers are of the "SFL" type. The large and small pulleys can be easily seen.

#### Antenna and Ground Connections

The three binding posts on the sub-panel, together with the two on the coil support base, form a means of connection in any of several combinations. The first one of these posts is connected to the grid end of the detector input coil (i. e., the secondary) thru a semi-variable condenser C3 with a maximum capacity of 30 picofarads. This permits capacity coupling to the antenna if desired. The next post is connected to the shield and the next to the filament circuit.

2. The picofarad, as has been stated before, is the same thing as a micromicrofarad. Putting it mathematically,

1 farad = 1,000,000 microfarads.  
1 microfarad = 1,000,000 micromicrofarads or 1,000,000 picofarads.

1 micromicrofarad = 1 picofarad.

Perhaps we will eventually have a good standardized name for the "µµfd" or "pfd".—Tech. Ed.

The two posts on the coil base are the primary-coil terminals. It can be seen that by the use of these 5 posts all possible combinations of grounded and floating filament and shield can be used with either magnetic or electric coupling to the antenna circuit. Some of the possible combinations are shown in Fig. 4. This is a desirable feature because the merit of the shielding depends to a considerable extent on the location of the set with respect to ground and disturbing fields.

**Grounding or "Floating" the Shield**

All of this revives the old questions—how long is the ground lead when it is connected to the water pipes on the third floor? Is it the length of the wire to the pipe, or is it the total length of wire and pipe to the actual ground level? The answer seems to be, "It depends on the frequency of the transmitter, or receiver, and the capacity of the piping system (or other analogous system)." A broadcasting station on the roof of a twenty-story building, using the frame of the building as a ground certainly has *not* a twenty-story ground lead! On the other hand, it will be found impossible to bring the metal case of a forty-meter shielded receiver to ground potential by connecting it to a thirty foot ground lead. These results seem confusing and contradictory until one remembers that the reactance of a 30-foot wire is large even at broadcast frequencies and at amateur waves may become so high that it makes little difference whether the lower end is connected to anything or not; the shield will "float" just the same. This also explains the difficulty so many of us (with stations far above ground level) have in attempting to bring the filament circuit of the transmitter to "cold" or zero r.f. potential. About the only practical way to accomplish this, in either transmitter or receiver, is to establish an artificial ground (counter-poise) of *high capacity*, tuned to zero reactance at the desired frequency. When this condition is encountered with the shielded receiver it seems to be most satisfactory to leave the shield ungrounded, although the operator's hand touching any metal parts of the set is liable to cause detuning. By different combinations with the five binding posts as described a best compromise can be had to suit most conditions. Some of the combinations are shown in Fig. 4.

**The Wave Traps**

The trap circuits shown in figure 5 are a convenience when the station is located in close proximity to a transmitter. 9ZA is only about 600 feet from the antenna of

broadcasting station WEBH, whose field is so powerful in the operating room of 9ZA that the station can be heard comfortably on the last stage of an audio amplifier. This is with all other tubes out and no antenna or ground connection. Naturally no amount of mere tuning will get rid of that

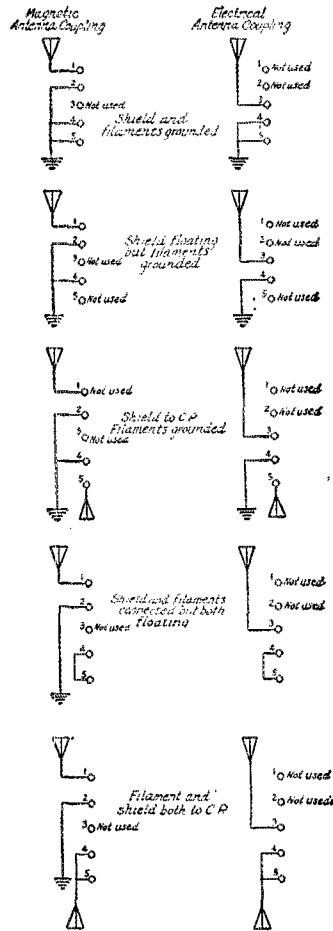

**FIG 4. SOME OF THE POSSIBLE ANTENNA AND SHIELD CONNECTIONS**

sort of pickup. Even the shielded receiver is quite helpless, altho it is perfectly "cold" to 9ZA's 1/4-K.W. transmitter 3 feet away. WEBH and WIBO will shock-excite the antenna and in this manner get into the set "all over the dial". This condition only maintains when the receiver is oscillating and a possible explanation is that the strong field of the broadcaster modulates the

carrier transmitted by the oscillating receiver. This seems far-fetched but is the only solution I have been able to find. No matter what the theory the *fact* is that the signal is there and can be very annoying. A simple trap shunted from antenna to

is in a location where the leak is at low strength and signals will therefore be stronger proportionately.\*

### Induction

Sixty-cycle induction is mostly caused by lighting cords, power leads, etc., very close to the receiver itself. Shielding will automatically cure this and judicious placing of the antenna lead-in to the receiver will prevent this wire from picking up the same noise. It is a fact that the portion of the receiving antenna *outside* the operating room (unless paralleling power lines very closely) will seldom pick up any hum.<sup>6</sup> The elimination of the A.C.-hum, will, of course, eliminate most of the induced noises caused by the operation of the transmitter. This allows a better break-in system as the operator is not distressed by a racket in his ears every time the key is pressed. As the break-in way is the *only real way* to operate a relay transmitter, this is a distinct advantage.

### Conclusion

The reader must not imagine that a shielded short-wave receiver will bring in more or louder signals from distant stations. It will bring in the same old signals, never louder and sometimes a very little weaker, but certainly will increase their readability to a great degree. The elimination of extraneous noises always increases the readability of weak signals very greatly and also makes audible a lot of new signals that we never imagined were there. The fellow fortunate enough to be located in the country or in a small town with no interference, no induction, no sixty-cycle hum (or in other words, radio paradise) has little use for shielding. To the unfortunate city amateur, who is prone to say—"ND, power leak", or "BC QRM", and who complains that he "never hears any foreigners thru the racket", it is a distinct boon. Consequently, we shall expect to see a greater number of complete broadcast receivers assuming the general aspect of an automobile chassis, and instead of "inductances that come in a box, like candy", (see QST Aug., 1919, Page 1), they may now come in a can, like tomatoes!

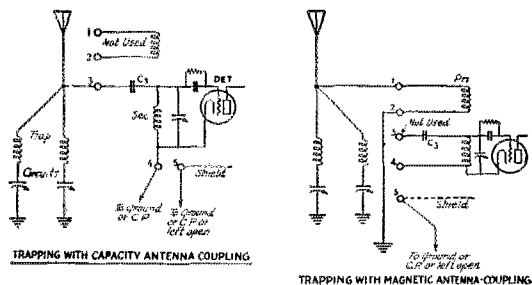

FIGURE 5—TRAP CIRCUITS

ground and tuned to the broadcaster's frequency, will *completely* kill all of this trouble. The trap should preferably be shielded and located a few feet away from the receiver itself. This offers only a small impedance, (depending upon the resistance of the antenna and trap circuits), to the broadcast frequency and so conducts practically all of this energy to ground. Two or more traps can be used, each set to one station. They never need be touched after once being tuned to eliminate the station. This stunt may be used with an unshielded receiver to alleviate the same trouble, altho it will not, of course, completely cure the trouble then, as some energy is picked up in the receiver itself and by the batteries, battery leads and phone cords.

### Power Leaks

The question of curing the power leaks is "something else again". Power-leaks are apt to be picked up in the receiver itself nearly as strongly as in the antenna.<sup>3</sup> A shielded receiver will cure part of the trouble to start with, then the antenna can be shifted around to get it into the position of minimum power-leak pickup without affecting signal strength. The third correcting factor, which I believe is due to Don C. Wallace of 9ZT, is the use of a very long receiving antenna (500-1000 feet) which will greatly add to signal strength without apparently adding volume to the leak. This antenna may with luck be so placed that the major portion of its length

3. There seem to be several varieties of these miserable noises. Some disappear almost completely when the antenna is off, others hardly lose strength at all. Can anyone suggest a theory—or show test results?—Tech. Ed.

4. There is room for argument on this matter. Tests are being made by a dozen members and there is an almost even division as to the results. Some obtain the same results as at 9ZT, others (including myself) encounter *more* noise and *less* signal.—Tech. Ed.

5. I know of at least 5 stations in which the induction hum from a 66,000-volt, 3-phase, 50-cycle line is least when the antenna is placed *parallel* to the high tension line. The distance between antenna and line varies from 60 to 3000 feet at these stations. I am unable to account for the effect but suggest a trial of the *parallel* position where induction is bad!—Tech. Ed.

# KFHW and the Trans-Pacific Yacht Race

By Stuart F. Wainwright\*

**I**N the 1926 San Pedro-Honolulu racing classic the 106-foot yawl Poinsetta of the California Yacht Club, formerly owned by the Crown Prince of Germany, successfully utilized 37-meter transmission in keeping the world informed of her progress. The Poinsetta was the only yacht in the race so equipped and having continuous contact with shore.

The accompanying photos show the short wave equipment and generator panel. The R.C.A. inductances were for an emergency 706-meter Hartley rig which was not used. The motor generator was mounted in a locker below the transmitter.

The equipment of 6BVG was revamped

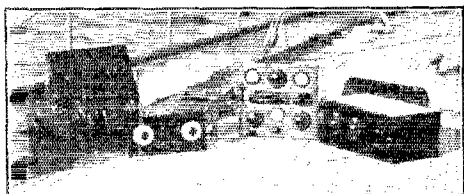

THE EQUIPMENT ON DECK

Left to right, storage battery, power panel, transformer, transmitter, receiver

to accommodate a single 203-A tube in the modified Colpitts circuit popularized by the C. F. Burgess Laboratories. A half-Kw. 500-cycle Navy Standard motor-generator was hastily secured in San Francisco for plate supply and the equipment installed two days prior to the start of the race. An antenna aboard the yawl with its masts of steel shrouds and halyards at first looked hopeless. As we were to be on the starboard tack for practically the entire run to Honolulu an antenna consisting of 25 feet of No. 14 enameled wire was run vertically up from the wardroom hatch. The distance between the antenna and shrouds was approximately 10 feet. A 12-foot length of copper tubing served as lead-in. It was impractical to use a counterpoise so a ground connection was made to the steel hull. There was no time or opportunity for testing the set before sailing.

After the rough weather of the first two days had subsided, and the north-east trade winds had put us on a more even keel, communication was established with 6CGW of Long Beach, thereafter nightly en route to Honolulu. 6CGW's audibility steadily increased as we went westward. K. L. Reidman deserves considerable credit in copying

our long QSS-ing press and position reports. No doubt all who heard KFHW knew that we were rolling our way across—and we did!! hu6TQ was the first Hawaiian Station to pick up KFHW, when we were three days out from San Pedro and was QSO nightly for the rest of the trip. hu6BUC picked us up after 4 days out and, keeping a continuous watch, faithfully handled our Honolulu traffic. The best DX worked was u4SI of Atlanta, Georgia, and u9AEK of Topeka, Kansas. A station which sounded about a mile away on the morning of June 19th proved to be Alaskan 7MN of the U.S. Naval Aerial Survey Expedition at Ketchikan. The distance on the chart was 2200 miles. I have never heard such phenomenal signal strength for that distance. 7MN was worked and given several messages.

The stations worked and who took traffic from KFHW were: 4SI, 6AIJ, 6AFS, 6BYE, 6BOY, 6CAE, 6CGW, 6CHY, hu6BUC, hu6CFG, hu6TQ, 6ZBJ, 6DEK, 6NP, 6RY, 7MN, 9AEK, 9BPT and NPM. There is not room here to list the stations heard. Some East Coast stations came in with loud speaker volume.

Short-wave radio conditions aboard a yacht on an off-shore race are quite different from those found in the average amateur's station or even aboard a 20,000-ton passenger steamer. There is more salt dampness to contend with; antenna limita-

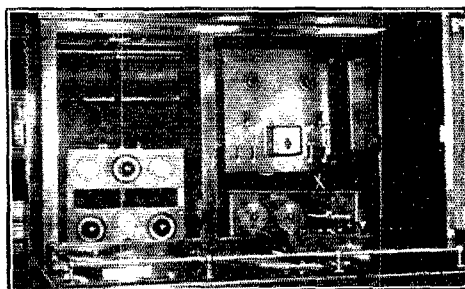

THE SET IN PLACE

tions; noise due to the rigging and the constant changing of antenna capacity. Again if the antenna is carried away while a spinnaker is being bent and the operator is in the middle of a message he must not lose his patience. In spite of the above difficulties the press received our daily report and a considerable number of personal messages were handled.

\*6BVG. 1926 Delta St., Los Angeles, Cal.

(Continued on Page 67)

# Voltage Breakdown in Transmitting Condensers

By Bert E. Smith\*

WHEN fifty watters were big things, and fifteen hundred was plate voltage of mastodonic proportions, almost anything could be used as a transmitter tuning condenser. If the darn thing flashed over, the answer was simple—tune fewer turns with more capacity. Maybe it was not quite so efficient, but it did the trick and probably did not detract any more from the way the set worked than leakage across the inductance or a half dozen things that were not thought of at all.

With the advent of higher power, however, a number of new considerations came into being. A brief review of two or three of the principals governing the voltage applied across tuning condensers may not be amiss.

Figure 1 shows an ordinary plate circuit of let us say, an r.f. amplifier. The generator at G is supplying 2500 volts to the plate of the tube. The plate inductance Lp is tuned by the variable condenser Cp.

Now then, a condenser tested for 3,000 volts flashover can not be used as Cp. Let us refer to Figure 2. Line ab indicates the d.c. plate voltage applied when the tube is in operation. When an oscillating current is set up the potential across condenser Cp will increase and decrease within maximum limits of the applied voltage which is 2500 as indicated by aXYZb. In other words, if the tube is operating at maximum efficiency, potentials as high as 5,000 volts might be obtained. With pure d.c. on the plate and if a modulated current is applied to the plate, even higher voltages will be reached.

Now let us consider the antenna circuit.

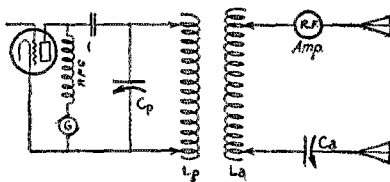

FIG. 1

In this (depending upon the number of turns used, degree of coupling, resistance, etc.) even higher voltage may occasionally be generated, and therefore, the e.m.f. across Ca, if such is used in the antenna

circuit, may occasionally go as high as two or three times the voltage across Cp. When selecting a condenser for plate and antenna tuning be sure to get one with a tested r.f. voltage breakdown at least fifty percent higher than the plate voltage you expect to use. For the antenna a breakdown voltage of double the plate voltage is desirable.

## R. F. Breakdown Voltage

Most manufacturers test condensers with 60 cycle a.c. and some at d.c. but do not

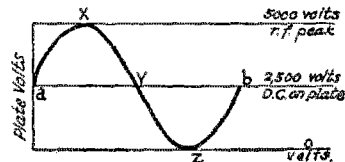

FIG. 2

take the trouble to make an r.f. test although the condensers will be expected to work with r.f. voltages applied.

Contrary to the usual impression, the spacing of the plate is only one of the factors in determining at what point a flashover will take place. This may be readily understood when some figures are looked at. For example, between needle points 10,000 volts will jump a half inch gap, while between two and a half inch balls, nearly 25,000 volts is required to bridge the same gap. In other words, if we have 5,000 volts we require a spacing of at least one-quarter inch between the needle points whereas between two and a half inch balls a gap of a trifle more than one-sixteenth of an inch will hold safely. Another consideration to be taken into account is that at high frequencies there will be a pronounced brush discharge between the needle points even though there was no actual flashover, while with the balls there would be practically none. This principal applied to condensers becomes quite important—for a truly high voltage breakdown the condensers should be so arranged that there are no sharp edges or corners on the high potential side of the condenser.

Many other things must be considered also—the type of the insulation and particularly its position in regard to the electrostatic field of the condenser are impor-

\* Allen D. Cardwell Mfg. Corp., 81 Prospect St., Brooklyn, N. Y.



tant. Unless the insulation is placed absolutely outside of the direct field there will be losses on that account.

We have found that a condenser designed merely by spacing the plates and then tested on low frequency (60 cycles) may pass with flying colors and still fail to operate properly when built into the set and subjected to r.f. voltages. Therefore, it becomes necessary for the amateur who insists upon proper material, to determine the approxi-

include modulation. However they are still perfectly good for *comparing* different condensers.

The capacity of the condenser at the breakdown point is of course easily measured by substitution in a tuning circuit where the capacity is known.

The exercise of a little thought and experimentation before putting a transmitter together may result in an appreciable saving of time and grief after the set is done. You know how it feels to build a nice transmitting set and then have things begin to pop. If you know what your voltages are likely to be and what the condenser will stand before you put the set together, you are reasonably sure to be protected from this trouble.

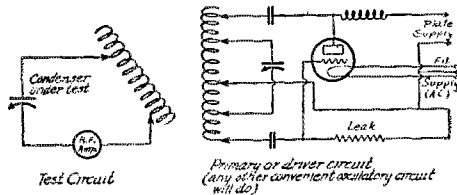

FIG 3

mate breakdown himself before building condensers into a set. A comparatively simple method of testing is shown in figure 3. An ordinary oscillator is set up and a closed circuit containing a variable inductance, the condenser to be tested and a radio frequency ammeter is coupled to it. Tune the oscillator to approximately the desired wavelength. Then tune the closed circuit to resonance. Even though the oscillator is of moderate power it is possible, by varying the taps on the coils and the degree of coupling, to be able to produce large currents in the circuit. Now vary the taps and coupling as thus described until a point has been found where, when the closed circuit is at resonance, a spark will jump across the test condenser.

When the flashover point has been found, the reading of the ammeter just before the breakdown should be taken, and then the r.m.s. voltage across the condensers at that instant can be determined by the following formula:—

$$E = X_C I \text{ or } E = \frac{1,000,000 (I)}{2\pi f C}$$

- Where E = Voltage
- I = Current
- f = Frequency in cycles
- C = Capacity in microfarads

This method can be depended upon for values within 5% if d.c. plate supply is being used on the driver and the tube is run well below normal rating so as to get a decent wave form. If a.c. plate supply or badly filtered d.c. is used the calculated values will not be correct as they do not

## A.R.R.L. Information Service Rules

Please help us by observing the following rules:

1. Keep a copy of your questions and diagrams and mention that you did so.
2. Number the questions and make a paragraph of each one.
3. Make diagrams on separate sheets and fasten them to the letter.
4. Print your name and address (not merely your radio call) on your letter. Don't depend on the return address on the envelope as this is destroyed when the letter is opened.
5. Don't ask for a comparison of the various manufacturers' products.
6. Before writing, search your files of QST—the answer probably is there.
7. Address all questions to Information Service, American Radio Relay League, Inc., 1711 Park Street, Hartford, Conn.
8. It is not essential to enclose an envelope as long as you supply postage and **PRINT CLEARLY** your name and address on your letter.

Any back issues of QST to which we refer you are obtainable from the Circulation Department for 25 cents each.

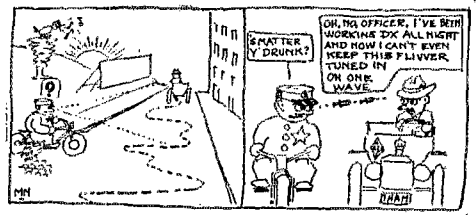

## Experimenters' Section Report

**S**INCE the details of this section have not been printed for a number of months they are given here.

The Section is informal to the last degree, consisting of nothing more than an information exchange for men interested in the experimental side of radio. In order to be able to handle this exchange with the least possible delay, things have to be systemized to some extent, hence each man is asked to apply for enrollment blanks on which are listed those problems which seem to be of greatest present interest. The list is sent him in duplicate; he marks both and returns one copy addressed "Experimenter's Section, A.R.R.L., Hartford, Conn." After that he is sent the list of the men working on the problems he has chosen, also such outlines as have been made on the various problems. These outlines are mimeographed affairs that are revised from time to time as the members suggest.

That is all—there are no officers, formalities or duties other than the general duty of letting your fellow workers and QST know what progress is being made.

From time to time, bulletins of various sorts are sent out, schedules of tests to men working on transmission matters, notes as to various new ideas that have turned up, etc.

### Electrolytic Rectifiers

An arrangement has been made with Mr. Junius D. Edwards, Assistant Chief of Research for the Alumium Co. of America, whereby we will be able to make some well-

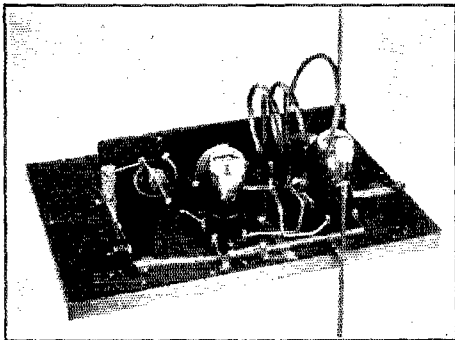

C. H. WEST'S 5-METER TRANSMITTER

The set normally operates with VT-14 tubes and is surrounded by a metal shield from which the antenna system protrudes.

controlled tests of aluminum rectifiers with materials of known grade and under proper transmitting conditions. The cooperation of a number of members of this section is

needed. The materials will be furnished except for the lead electrodes and possibly the jars. It will be necessary to set up the rectifier and to operate it under usual sending conditions. It will be necessary to keep a *complete* record. If a successful rectifier can be evolved, a very great good will have been done to amateur transmission and we will have something that will take the place of the tantalum rectifier which has been made unavailable.

Please write about this matter separately—not in a letter referring to other things also. Postal cards will be ignored.

### 5 Meter Progress

As was stated last month, Italian 1ER has been heard in Tripoli when working at a wavelength near 5 meters. The recep-

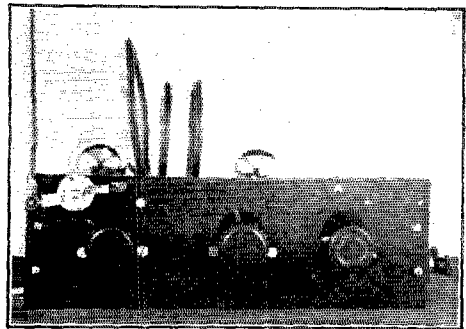

FRONT VIEW OF THE WEST TRANSMITTER, SHOWING THE TELESCOPING ANTENNA AND THE ANTENNA-CURRENT INDICATING LAMP

tion was accomplished in September on one evening of a test that ran thru the evenings of a week. Unfortunately, details are either lacking or do not agree, as received from different sources. The points on which we are sure at present are that the transmitter used two tubes (rating unknown) in parallel in the Armstrong tuned-plate, tuned-grid circuit and that the receiver was of a conventional sort with an oscillating detector and audio amplifier. The receiving station was operated by Captain Fillippini of the Italian army. The transmitter was operated by Mario Santangeli, who is a radio engineer by profession. The only photograph so far available is too small for reproduction.

### The 2AUZ work

The transmission from 2AUZ to Hammond, Indiana, was reported briefly on

page 13 of our November issue in the "vest pocket" section report. Further details on that test are as follows.

2AUZ transmitted with a UX-210 tube operating in a circuit like that shown on page 34 Fig. 1A of the July issue. Each half of the inductance consisted of 3 turns  $1\frac{1}{2}$ " in diameter. The chokes were normal. The antenna system consisted of two rods placed parallel to each other with one

the photos, where it is unfortunately somewhat misrepresented by having receiving tubes in the sockets which are normally filled by VT-14s. The circuit is the familiar Vallauri-Mesny "back-to-back" arrangement (Fig. 10, page 34, July QST) and the antenna consists of a pair of telescoping curtain rods which are partially shown in the photos. These rods are extended up until the fundamental of the system is

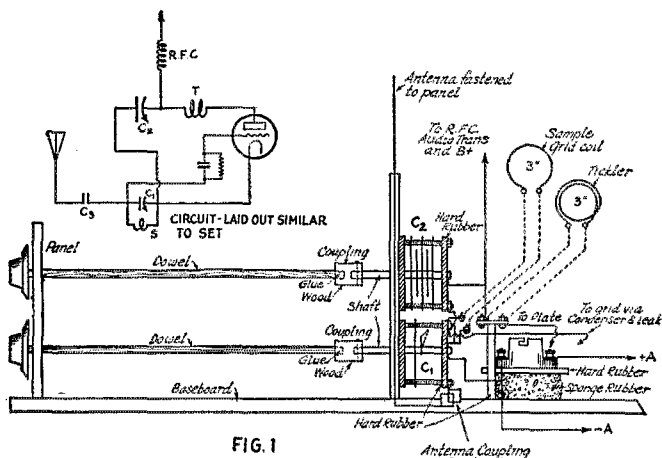

FIG. 1

FIG. 1. THE NEW WEST RECEIVER

The secondary tuning condenser has a single stator plate and a single rotor blade as shown in Fig. 2. The regeneration control is a 5-plate variable condenser with two rotor plates between 3 stator plates that are spaced  $\frac{1}{4}$ " apart. The antenna is a vertical rod whose lower end terminates in a metal plate  $\frac{1}{4}$ " square spaced  $\frac{1}{4}$ " from a similar plate connected to the grid side of the tuned grid circuit.

extending beyond the other, constituting a sort of "Zeppelin antenna". The combination was fed by an input circuit consisting of a coil and two variable condensers in series, the same arrangement as shown in Fig. 9, page 13 of the July issue, except that the extension was not kinked over as shown there.

This system has been replaced by one using an "H" tube and a longer two-wire line, each of the Zero-voltage points being permanently short-circuited (as is done in Lecher-wire work to locate the nodes) so that only one wavelength will operate. The free extension of the one wire is 100 inches.

#### C. H. West's Transmitter and Receiver

C. H. West of Stapleton, N. Y. and Brooklyn has been working with especial attention to the matter of steadying the wave of a 5-meter transmitter and making the receiver shock-proof, reasoning that these were necessary preliminaries before any serious and consistent 5-meter work could be done.

The transmitter is shown adequately in

equal to the operating wavelength. The system is, of course, considerably loaded by the single inductance turn at the center and is therefore not as long as might be expected. A flashlight lamp is used as an antenna-current indicator (shunted when necessary) to avoid the loading effect of a meter.

The transmitter normally works inside a metal box, only the antenna protruding thru suitable openings. The antenna can be approached without affecting the received beat note though the signal strength naturally varies. When the shield is removed the set shows the usual bad body-capacity effects.

#### The West Receiver

To work with this transmitter there is a receiver laid out with special thought to shock-proofness and to reduction of the appalling noises common to 5-meter sets. The general construction is shown in the drawing which also shows that here is ONE receiver which does not attempt to tune from 3 to 7 meters at a half-turn of the

controls. The tuning range in the neighborhood of 5 meters is about  $\frac{1}{2}$ -meter, which is more rational than our customary practices. Quoting from Mr. West's letter—

"The sockets are set on large rubber bath sponges; the sponge is glued to the baseboard and the socket is glued to the sponge. To prevent vibration noises no stiff wires are soldered to the sockets. A thin connection of copper foil was tried but was not good enough. It still allowed a little noise to come thru. A short length of No. 40 wire was wound in a very small spiral and then stretched slightly. This was then soldered to the bus-bar and the socket binding post. This was "the goods". You can now tap the baseboard with a pencil and nary a noise do you hear."

The set uses 5 secondary inductances (with some overlap) in the 5-6-meter region.

### Field Tests

Even before this last receiver was done, some field tests had been made. A range

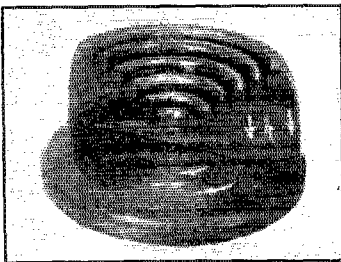
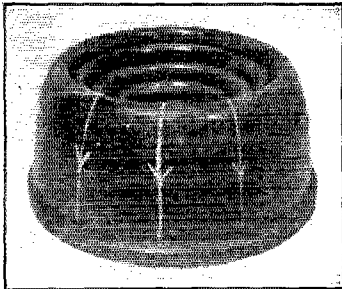

MR. WHITE'S COMPLETE MODEL. THE CHALK MARKS REPRESENT ELECTRIC STRAIN LINES. THE MODEL WITH ONE HALF REMOVED SO AS TO SHOW THE INTERNAL MACHINERY OF THE ADVANCING WAVES. CHALK MARKS SHOW THE ELECTRIC AND MAGNETIC LINES.

of 24 miles was obtained with *good signal strength*, receiving being done in a moving automobile. A curious effect was observed—there were "dead" points about

twelve feet apart along the road. How does one account for this? There were two listeners and both are sure of the effect. Mr. West comments further to the effect that he is absolutely sure that no "junky" and unshielded receivers and transmitters will ever get us anywhere in the 5-meter field; that it is essential that we make things firm and well-shielded if we ever hope to get out of the block. Note, inci-



FIG. 2. THE ROTOR BLADE OF THE TUNING CONDENSER, ACTUAL SIZE

This is twisted as shown in Fig. 1. The minimum clearance is  $\frac{1}{16}$ ".

dentally, that the 24-mile work was done with UX-201-A tubes (receiving tubes) in the sockets and thru the ignition noises of the car, showing that there must be some question as to the alleged rapid absorption of 5-meter waves. This is in thorough agreement with the results obtained in the Phelps tests at Jamaica.

### 40 and 80 Meters

One of the really urgent questions in amateur radio is the one of devising an antenna that is equally good in the 40- and 80-meter bands, the two most commonly used in combination. A little thought will show that in any ordinary system the voltage and current distributions change in a most inconvenient manner when making this shift so that a different feed method becomes almost essential. A circular on this matter has been sent out, basing on a very good analysis made by Mr. E. G. Watts of Miami. Can someone help?

### A Wave Model

Mr. F. W. G. White of Wellington, N. Z., is the contributor of the very pretty model shown by one of our photos. He has devised it for instructional work but it appeals to the writer also as deserving some sort of a name as a piece of sculpture. Perhaps it deserves such a name as "The Birth of a Hertzian Wave."

### Transmission Theory

In the last issue of the I. R. E. proceedings is presented a paper that was read before the New York section on Sept. 1. The paper is by Young and Levin of the Radio Department of the General Electric Co., and gives some very vital information on the use of amateur antennas. The discussion centers around the variations in

(Concluded on Page 61)

# dg1XL, University of Michigan Greenland Expedition

By P. C. Oscanyan, Jr.\*

**T**HE University of Michigan's Greenland Expedition was taken to Holstenborg, Greenland, by the Schooner *Morrissey*, which then proceeded on the business of the Putnam Expedition. Our expedition was thus left dependent upon the *Morrissey* and therefore, in turn, on our radio contact with her. Manley on the *Morrissey* (signing VOQ) was able to keep

transmitter and receiver, with which we could test locations and with which we incidentally could maintain contact with the *Morrissey* as has been mentioned.

The transmitter was home made and used a pair of CX-301-A tubes in a Hartley circuit; "B" battery operated. We used no special parts but depended upon well-known products.

We operated at 38 and 41 meters and consistently covered over a thousand miles in working with VOQ, although the plate voltage was only 200.

Last summer's work was done with a receiver made for the expedition by the Burgess Battery Company. The case of the receiver is of aluminum, an ideal material for a set that must be portable and yet must withstand rough handling. The set has a regenerative detector and two stages of a.f. amplification, only one step being used except when I entertained myself with short-wave broadcasting from WGY or KDKA. Here, too, the parts were standard. "Plug-in" coils permitted a ready shift of tuning range.

The sectional bamboo mast was 2 inches in diameter, 35 feet high and had six guys, each broken in the middle by a Pyrex insulator. Pyrex insulation was used for the



THE AUTHOR

in touch with us on schedule so consistently that all traffic went thru without a single hitch.<sup>1</sup>

Our expedition went into Greenland last summer to gather meteorological data and to lay down a base station for the extensive work which is being planned for next year. The work of this expedition was solely scientific and to do it full justice would require all the space in this issue of *QST*. However, there is space to tell of the radio work.

Among the things most necessary, it was important to locate a suitable place for the radio station which we plan to erect next year, in order to keep in direct touch with the United States and the rest of the outside world. In establishing a radio station for an expedition, nothing should be left to chance or good luck, therefore, we took with us this time a small portable

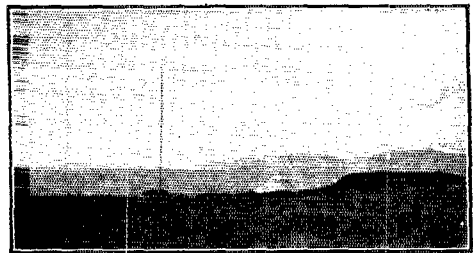

LOOKING WEST ACROSS THE STATION LOCATION

antenna and counterpoise. The single wire antenna was 40 feet long while the fan counterpoise was composed of three twenty-foot wires.

This arrangement worked beautifully. We worked the *Bowdoin*, WNP, when she was off the coast of Labrador, also VOQ up to a thousand miles and beyond as mentioned before. Over 125 American amateur stations were heard. The Brazilian amateur sta-

\*In charge of expedition radio, also 2AZA, 49 Larch Ave., Bogota, N. J.

1. The transmitter "VOQ" of the *Morrissey* was shown on page 17 of July, 1926, *QST*, where appeared also some details on the American Museum (Putnam) Expedition.—Ed.

tions were wonderfully consistent as were also the English ones. An acknowledgment card is to be sent to every station heard.\* The station was set up in the "pup" tent

### The Graphs

Before we left, John L. Reinartz told us that for all wavelengths from 50 meters down, there is a 17-degree shadow-angle which cuts out all signals; that is, no signals will be heard behind a hill whose crest rises more than 17 degrees from the horizontal as viewed from the receiving point. This we tested by first establishing the station down in the valley or bowl where our tents and storehouses were located. The station was then moved to a point some 400 feet high which projected out into the fiord so that, with the exception of a small hill behind us, the angles to the hilltop were in no case in excess of 17 degrees. These angles were checked by a theodolite. The photographs show the station located on the point. We were north of the Arctic Circle and summer is short there so that late in August the mountains behind the station acquired snowcaps.

Referring to Fig. 1, we see a series of graphs showing the average audibility of the stations heard from each U. S. Radio District between 8 p. m. and midnight of each day during the test just described. These graphs were made by averaging the "R audibility" of the stations of each district.<sup>2</sup> Let us say here that all districts were most carefully watched for. The graphs do not take into account the number of stations heard and in some cases a district was "saved" by a single station. The surprising thing is the general high level of audibility which seems to obtain. There were some nights when no station was heard, but these were sometimes followed by a night when the air was full of stations. In the measurements it was necessary to estimate the audibility values by ear alone,<sup>2</sup> but personal bias probably entered less than is usually the case in such work. There was always present the sobering thought that the correctness of the data would determine whether next year's work would stand or fall. The curves, therefore, should have some weight and by analyzing them one can determine the extent to which the 17-degree theory was substantiated. In doing this, one must remember that the "valley station" of July was shielded in all directions from which signals were received.

### Further Plans

Because of great pressure of other work, we were not able to take up the 15-meter work which had been planned for daytime. Next year this phase of radio will receive close attention.

2. The "R" system of signal intensities is admittedly not accurate but nevertheless is about the best thing available in the absence of an audibility meter!—Tech. Ed.

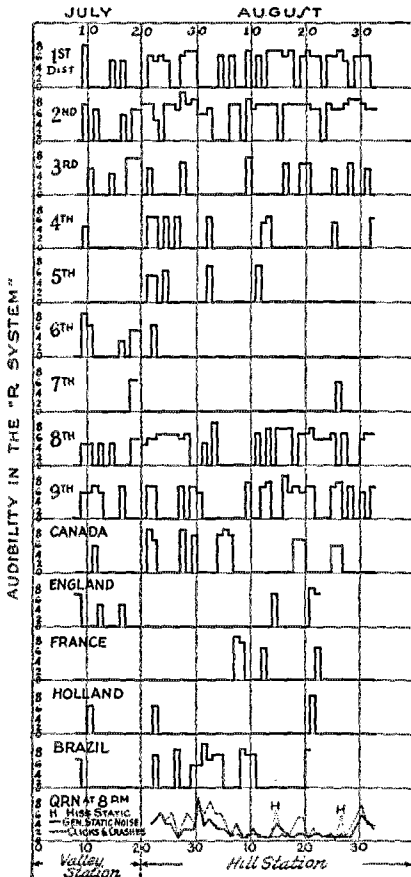

FIG. 1 AVERAGE "R" AUDIBILITY FOR DIFFERENT REGIONS FROM JULY 8 TO SEPTEMBER 3

The measurements to the left of the dashed line, that is to say the July measurements, were made at the valley station, while those to the right of this line were made at the hill station. The average for each day is from 8 p. m. to midnight eastern standard time, while the measurements of static were made at 8 p. m. Measurement of static for each day was made in the 40-meter band at 8 p. m. eastern standard time after which signal strengths were observed until midnight.

shown in the photograph, at a place about 40 miles inland from Holstenborg. Operating the set was an acrobatic trick since one had to sit with the feet straight in front, enclosed in a sleeping bag for comfort, and then operate by twisting the body around. It was like sitting up in bed and operating.

\*See *Calls Heard*, page 56.

Dg1XL (dg is the temporary intermediate we have adopted for Greenland, which is a Danish possession) expects to be on the air next summer and probably next winter (1927-28). A 250-watt tube is to be

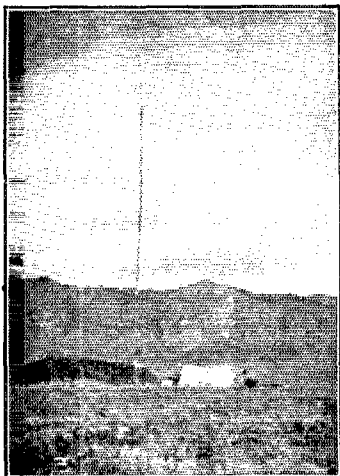

LOOKING NORTH ACROSS THE STATION LOCATION

used. Work will be done in the forty-meter band, the wave to be set with the General Radio 358 wavemeter which will give a common standard for us all to go by.

Thus you see how a U. S. amateur has set up the first short-wave amateur station in Arctic Greenland. Next summer I hope to be QSO with all whom I hear, for this is an amateur and experimental station and the University takes as much pride as anyone else in the radio progress made there. The message traffic will, of course, be very important also.

## TRANSMITTING HINTS

### "Ur QSB F B"

What's the sense of such bunk as "Ur QSB F B"? We have heard it hundreds of times and it is nonsense—does not mean a thing. The international list says that "QSB" means "Your note is bad".

If that's what it means why stick "Ur" in front of it, incidentally what is the object of saying "bad" and then following it up with "Fine Business"?

If the note is bad—"QSB"

If the note is good—"Ur tone F B"

The second statement is shorter than the dizzy thing at the top of this paragraph—if you don't believe it just add up the dots and dashes.

### Helix Strip

6ARX has been "junking" and finds that the copper strip from an old Ford magneto makes good material for winding a transmitting (or receiving) loop. It can also be used for wiring the transmitter.

It seems to me we remember several helices in the Ninth District that were wound with the same material.

By the way, brass linoleum strip or rug binding is not half bad. Be sure it is brass and not just brass finished. The zinc strip is N.G.

### Transmitting Grid Leaks

2AOP suggests that a good transmitting grid leak can be made by connecting the two halves of a 10,000 to 100,000 Bradley-ohm in parallel. The device is said not to heat up when used with a 50 watt tube but we imagine the adjustment of this particular tube is such that it takes less grid current than most we have seen.

### Secondary Filament Rheostat

Not everybody can use a primary filament rheostat because one has to have the thing before one can use it and these rheostats are mostly somewhat higher priced than the usual secondary variety. A stunt for dodging the difficulty is shown in the cut herewith. Set the two rheostats alike and the center tap remains undisturbed. One can connect the two rheostat arms together so that one knob will operate them, although it is hardly worth the trouble.

### Transmitting Condensers

The antenna condenser and even more the primary condenser of a tube transmitter becomes quite a problem when the set is operating at a wavelength above 80

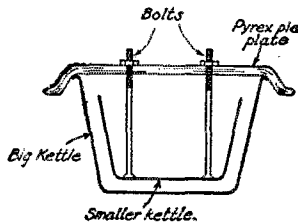

meters or with a power exceeding a couple of hundred watts. A beautifully simple condenser, capable of standing a great deal of misuse can be constructed as shown by the cut herewith.



5 "MILLS"

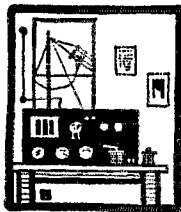

# Amateur Radio Stations



z2XA, Wellington, N. Z.



signed as Chief of the Governmental Telegraph Service after *forty-four* years in that game.

The photo of the radio room shows both transmitter and receiver. The lead-ins from antenna and counterpoise come through porcelain bushings five inches long. These bushings are set in the window panes seen at the top of the photo. The antenna and counterpoise are brought to two single-pole double-throw knife switches (insulated by corrugated porcelain stand-off insulators) which serve as grounding devices. Directly under these lighting switches is seen a single-pole double throw "send-receive" switch. In order to make all leads as short as possible, this switch is mounted in the position shown. It is operated by means of lanyards attached to the blade of the switch. All of the wiring and connecting leads in and to the transmitter are of copper strip.

The transmitter is placed on top of a small bench, the legs of which are insulated from the operating table by porcelain cups. The transmitting circuit is a loosely coupled Hartley and the tube is a 50-watt Western Electric. Since the photograph was taken the transmitting inductances of edgewise wound strip have been replaced by flatwise strip with the result that the output has been increased 15 per cent.

Plate supply comes from a 250-watt Esco motor-generator unit mounted on a concrete base directly below the operating table. All indicating meters are Weston in-

**F**OR a long time we have been after this description of the internationally known station of the Shrimptons (father and son) at 38 Rongotai Terrace, Wellington. The station is a consistent performer and the operation of 2XA leaves nothing to be desired—and this is not surprising for the Senior Op has recently re-



struments. The filament supply comes from the a.c. lighting mains, through a step-down transformer.

At the left of the transmitter is a B.C.L. receiver and under it (and on the operating table) is the high frequency receiver, the circuit of which is really a Hartley but goes under a variety of other names. The receiver has two stages of audio frequency amplification. For headset work one stage is used. When loudspeaker signals are desired, the second stage is plugged in, and the small speaker between the transmitter and B.C.L. receiver is used. The B.C.L. receiver operates the loud speaker at the left of the illustration.

On top of the B.C.L. receiver is a Heising modulator which is used for phone work occasionally. The individual with the headset on is the elder Shrimpton who is also an enthusiastic deer stalker. That accounts for the fine 16-point stag head shown on the back wall.

The other illustration shows the residence in which 22XA is housed, and the very beautiful antenna layout. The masts are of steel and are 136 feet apart. Both masts are about 80 feet off the ground. 2XA has gone through all evolutions of antenna building; beginning with a flat-top and multiple down leads, then all sorts of cage affairs. The present antenna is a single

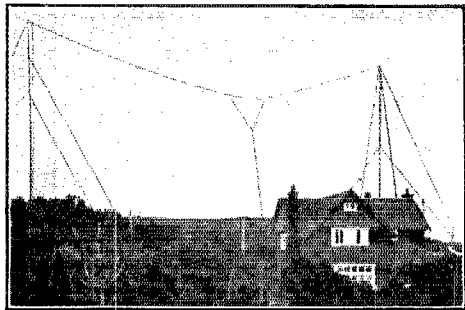

No. 8 hard drawn copper wire 50 feet long which is the top of a triangle of copper, the other two sides of which are 14 feet long. The insulators attached to the triangle are of heavy plate glass, eighteen inches long and an inch and a half wide. There are four porcelain eggs between these plate glass insulators and the masts. The mast stays are well cut up into short insulated sections.

The counterpoise is supported by three short poles. A single wire arranged in the form of a "T" is used.

Unfortunately, the Junior op was not present when the photos were taken. Needless to say both operators have done a tremendous lot of DX work, traffic handling and rag-chewing.

## 3VX, Audubon, N. J.

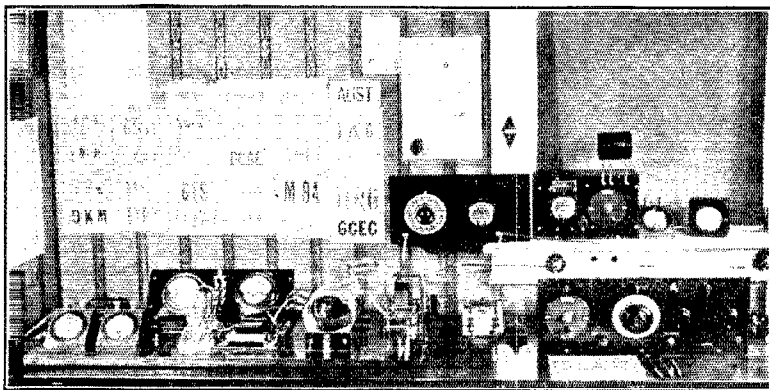

**C.** H. JENKINS of 3VX started in wireless in 1912. There was no one to help him with the code so his initial efforts soon died out and the set was relegated to the junk pile only to be brought out and put in operation when the broadcasting boom started. Then he got hold of a copy of *QST* and broadcasting went by the board. With the aid of 3BHG his present set was started

off in February of 1925 and he has been hard at it ever since.

The radio room is located in the rear room of a bungalow and for that reason Jenkins has made a particular effort to see that both transmitter and receiver present a neat appearance. The transmitter uses the familiar coupled Hartley circuit with two tubes, varying from 201-As to 210s. All of the

apparatus with the exception of the antenna ammeter and series condenser and the power supply is mounted on a white pine board. All leads are of quarter-inch copper tubing insulated with glass where any of the high frequency might touch wood instead. The inductances are also of quarter-inch copper tubing, and rest on Pyrex glass tubes. No lead in the transmitter proper is over six inches long.

The plate power consists of a chemical rectifier fed by an Acme plate transformer. Switches are used for low and high powers.

A filter consisting of two RCA 40-henry chokes and seventeen  $\mu$ 's are mounted under the operating table.

The receiver shown at the extreme right uses a modified Hartley circuit and is a plug-in affair. It uses a detector and two stages of audio and brings in signals from all over the globe when QRM and power leak QRN are not too bad. On the window is the

wavemeter which was built to Bureau of Standards specs and uses a fixed crystal detector and a 0-10 mil d.c. meter for resonance indication. This device has proven to be very sensitive and rugged.

The antenna consists of a two-wire flat-top supported between a 60-foot tower at the far end and a 30-foot pole at the house end. The counterpoise has three wires fanned out from the lead-in bushing to fourteen feet at the far end. The antenna and counterpoise are insulated with 5 & 10 glass towel bars. A separate receiving antenna is used for break-in purposes.

The station's DX includes New Zealand, Brazil, France, Mexico, Cuba, Porto Rico and all of the U. S. Jenkins has an RCC certificate, an O.R.S. certificate, an Army-Amateur Station certificate and is Route Manager for Southern New Jersey, all of which show that DX is not his only aim in life.

## 7IT, Portland, Oregon

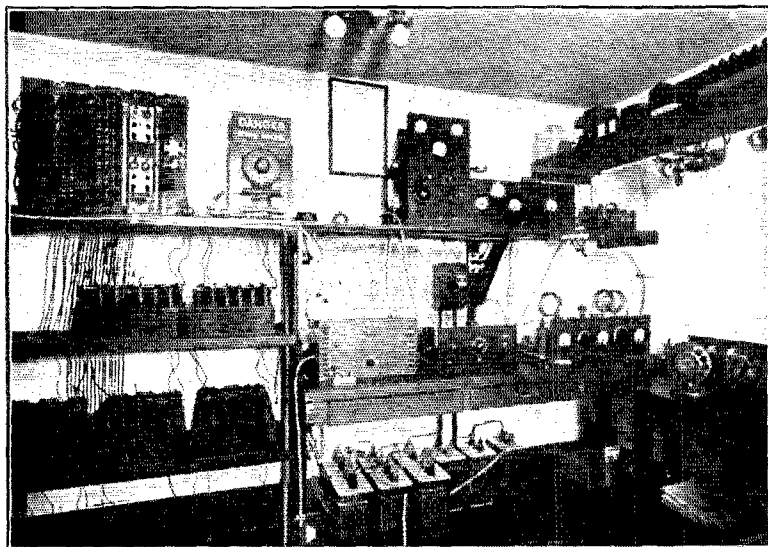

**T**HIS is another father-and-son station, being constructed and operated by Ashley C. Dixon, Sr. and Jr., at 1350 East 36th Street, Portland. Both the Dixons got the radio bug about four years ago, the elder starting off in the B.C.L. game and the Jr. in the ham game. 7IT is a combined broadcast and amateur station. Most all of the broadcasting work is done by the Sr. Dixon, the Jr. tending to the short-wave end in the main.

The station has several unusual proper-

ties. The comparatively high-power transmitter (one 50-watt) is supplied with battery power, both filament and plate. An active broadcasting station and an equally active amateur station are combined in one at 7IT. An exceptionally large antenna-counterpoise is used.

As seen in the photograph the antenna masts are self-supporting and are sufficiently rigid to be climbed with safety. They are 145 feet apart and 68 feet high. The antenna is a six-wire flat-top and the

counterpoise is also a six-wire affair. The broadcasting outfit is operated at the fundamental of the antenna while the short wave set operates at the 5th harmonic of the antenna. The lead-ins from antenna and counterpoise enter the station through Pyrex bowls.

The transmitter uses a single 50-watt Western Electric tube in a tuned-grid tuned-plate circuit. This transmitter sits on the operating table to the right of the receiver. Ordinarily the storage B batteries shown at the left are used on the s/w set. Occasionally when the batteries are being charged the 500-watt Esco motor-generator is brought into use. This generator is situated in the cellar below the operating room. Filament supply comes from the large storage battery units beneath the operating table. The combination of a rigid antenna system, filament-and plate-battery supply, the tuned-grid tuned-plate circuit and sponge mountings for the transmitter to eliminate vibration, results in a note which is invariably mistaken for a crystal controlled transmitter.

The short-wave receiver (in the center of the photo) uses the conventional throttle control of regeneration with a UX-200-A detector tube. Dixon says it is a poor morning indeed when z2XA cannot be heard six feet from the phones, while on a good morning his sigs can be copied fifteen or twenty feet away—and this on a single stage of audio frequency amplification.

When operating the set, it is the custom to leave the filament of the W.E. tube burning all the time. This eliminates the warming up process and the resultant change of

transmitter frequency which, however seems to be only about 2,000 cycles at 7IT. The only thing which seems to change the char-

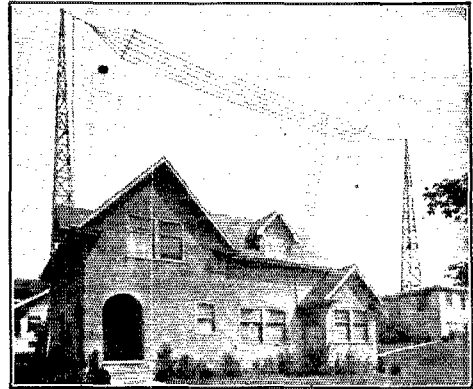

acter of the emitted note during normal operation is the vibration of the transmitting inductances. The sponge rubber pads under the transmitter baseboard take care of most of this trouble.

7IT is always open for traffic although no determined effort is made to grab gobs of it since the station is primarily an experimental one. The ops are no slouches at traffic work though. Witness 7IT's recent work with z2XA during the time that a local business man was in N. Z. and needed to get in touch with the U. S. Around 2,800 words of business messages were handled between the two stations.

**Correction**

In the article "The Flying Loop" in November QST, we printed the wrong cut for

Fig. 3. We are herewith reproducing the cut that should have been shown. We apologize to the author and readers.

**FIG. 3. THE MODULATION CIRCUIT**

Note that this does not change the original set at all, it merely supplies voice-modulated plate current to the set. The wiring to the left of the dotted line is a part of that shown in Fig. 1.

Ma 2—Meter to show oscillator plate current. The original meter now shows total plate current of three tubes.

Ma 3—Meter to show modulator plate current.

VT2—Modulator tube.

VT3—Speech amplifier tube.

L1—Modulation choke, 40 henry or more. L2—Choke to prevent modulation from plate of VT3 escaping to filament.

L3—Choke to prevent R.F. from reaching plate of VT3 or A.F. from reaching plate other tubes directly.

Both L2 and L3 are Ford spark-coil secondaries with the iron cores in place. An air-core R.F. choke may be used at "X" in addition.

MT—Modulation transformer.

Mic.—Microphone.

C1—Large condenser, 1/2 microfarad or more.

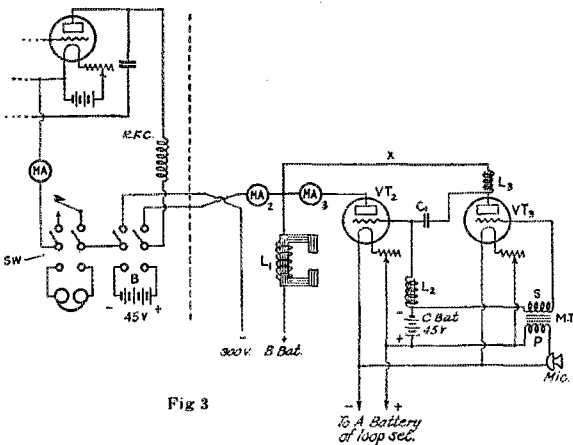

Fig 3

# Calls Heard



**F-8TBY-8KU, Tabey, 1 Place Abundance, Lyon, France**

iaac iaao iadm iaxa iber lbhb lbwn lch lcmf lemy  
 lenz ldi lkk lmy lzw 2acg 2aes 2afn 2agt  
 2ahk 2aib 2amj 2apv 2bs 2byg 2orb 2cth 2civ 2exn  
 2yk 2lm 2rv 2za 2zv 2zw 2ay 2bva 2cin 2co 2zx  
 4ji 4jk 4js 4ut 5zaz 5atv 5bay 5brc 5bth 5ccq 5es  
 8jq 9adk 9bpb 9day 9dng 9za a-2bb a-2eg a-2em  
 a-2im a-2no a-3bd a-3kb a-3ls a-4an a-7cy bz-lac  
 bz-lad bz-laf bz-laj bz-laj bz-lak bz-lal bz-lan  
 bz-lao bz-lap bz-lag bz-lar bz-lav bz-law  
 bz-lbd bz-lbg bz-lbh bz-lbi bz-lia bz-lib bz-lja  
 bz-2ab bz-2af bz-2aj bz-5ab bz-6qa bz-9qa bz-9qb c-lar  
 ch-2ah ch-2ar ch-3ij ch-3io ch-3iy pr-4sa pr-4ja  
 r-bal r-db2 r-fc6 r-2to r-rp ra19 s-2co s-2nd s-2nl  
 s-2nn s-2ns tj-cvj z-lau z-lao z-lax z-2ac z-2ae z-2aq  
 z-2bt z-2bg z-2br z-2gc z-2xa z-3ai z-3aj z-3ar z-3mg  
 z-3rf z-4aa z-4ac z-4ak z-4am z-4as z-4av u-abl u-dx8  
 bxy egkk jrg niss nkf nt munx sab sgt voq wghm  
 wnp.

**A. G. Weynton, 2 Cesca Flats, 36 Cranbrook Avenue, Cremorne, Sydney, Australia**

laci laao lacd laxa lbgq lbgm lch lckm lcmx  
 lga lka luo luw lxad lza 2agq 2ami 2atc 2le 2me  
 2no 2rm 2uo 2za 2zn 3ahl 3bnu 3buv 3bva 3kb 3kk  
 3lo 3lm 3mi 3wm 3ww 3zo 4ag 4hu 4iz 4li 4mv  
 4ro 4wo 4xj 5aq 5aab 5akn 5akt 5alq 5amn 5arn 5ask  
 5asv 5auz 5avf 5er 5dl 5dq 5ft 5kc 5kk 5ky 5lg  
 5nn 5uk 5ya 5wi 5ww 5yd 5arr 6adr 6adv 6ahn  
 6aj 6ald 6alr 6amm 6anp 6avy 6axw 6bbq 6bq 6bcn  
 6beh 6bek 6ey 6bh 6bj 6bl 6bls 6bm 6bv 6bo  
 6bat 6bs 6btm 6bus 6bv 6bw 6bwy 6bxc  
 6bx 6cy 6cey 6cev 6egw 6es 6cht 6chv 6civ 6cmg  
 6cmj 6cor 6esw 6eub 6dat 6ddo 6djl 6eb 6fw 6fx  
 6hj 6hur 6hv 6ih 6jn 6in 6kb 6kq 6ky 6lq 6mb 6nx 6oa  
 6oi 6pr 6pw 6qu 6rn 6rw 6sb 6sv 6ts 6tx 6ukm  
 6xam 6zv 7aek 7as 7dk 7d, 7hi 7id 7ix 7no  
 7pu 7rl 7vr 7wa 7wv 7xf 8adg 8aep 8aj 8alo 8amd  
 8bhm 8bon 8bpl 8cc 8dl 8daj 8del 8dqz 8don 8dx  
 8gz 8mtb 8oq 8nz 9aek 9aot 9bao 9bbf 9bhx 9bjn  
 9bpb 9bqe 9bv 9bwn 9bz 9ci 9ce 9che 9clr 9cmn  
 9cp 9cpm 9clj 9cpq 9dte 9euz 9evn 9exe 9ev 9da  
 9db 9dez 9dlj 9dng 9ds 9eek 9ect 9efa 9eij 9eji 9ek  
 9eig 9ejm 9eft 9ez 9fj 9kv 9kg 9mb 9od 9sl 9sw  
 9tg 9xi 9zt 9zx hu-6hd hu-6bdl hu-6buc hu-6sar hu-6axw  
 hu-6az hu-6tu hu-fxl hu-wyi hu-5ab au-7bh c-4gt  
 c-2rc f-8jn f-8kf g-2od g-6ab g-6tz j-lzq j-3kk m-ln  
 m-lj m-lx m-b6 m-4v m-9a pi-lau pi-lbd pi-lhr  
 pi-3aa pi-cd3 r-hal r-ha2 sme ska agbl octn bam rxy.

**A-3EM, C. H. Doudney, Dickens Street, St. Kilda, Melbourne, Australia**

laao lawe lbjd lbd lcmp lcmx ldb lhn lkm  
 lky lzma luw 2ab 2am 2av 2en 2mu 2uf 2zy 3air  
 3at 3kk 3imn 3lw 3lm 3ra 3zo 4ac 4af 4bt 4cek  
 4ft 4js 4lk 4rm 4sa 4si 5ado 5ag 5arl 5aw 5ak 5alq  
 5atr 5auz 5ef 5fl 5aur 5de 5uk 5aah 5aam 5aan  
 5acg 5adt 5aj 5am 5al 5aj 5amm 5an 5are 5asd  
 5bay 5bbq 5bbn 5bcn 5bd 5bge 5bh 5bu 5buc 5bse  
 5bvd 5bx 5bxa 5bxc 5bd 5bxj 5bxx 5bvm 5ege 5egz  
 5chy 5cto 5eub 5gh 5hj 5ka 5kq 5ph 5sa 5tq 5vr  
 5ww 5zku 7aj 7bh 7gh 7la 7mf 7no 8bh 8bpl  
 8ea 8od 8gz 8kc 8ux 8vy 8yz 9aan 9aek 9ak 9ap  
 9ajm 9axq 9bez 9bdq 9btr 9caw 9cc 9cu 9edf 9ek  
 9eks 9cor 9er 9et 9ks 9dq 9du 9dng 9de 9m 9lr  
 9nk 9pu 9tc 9za hu-6aj hu-6ak hu-6axw hu-6dl  
 hu-6nl c-5lc z-lap z-lau z-lax z-2bx z-2bx z-3af  
 z-3aj z-3ar z-4aa m-6asy pi-lbd j-lzb j-lth.

**A-3WM, W. J. McAuley, Union Street, Brunswick, Victoria, Australia**

al-7kx al-7mn b-8aa b-4zz bn-8kl bn-8k2 bn-vqf  
 f-8cs f-8ct f-8gm f-8ix f-8hm f-8jc f-8jn f-8jf f-8kf  
 f-8kfe f-8rz f-8tk f-8tby f-8tdy f-8ag f-8woz f-8rbp  
 f-8xh f-8odj f-8octn fm-8mb g-2bz g-2cc g-2kf g-2lj  
 g-2nm g-2od g-2bg g-2sz g-2to g-5lf g-5oc g-6td gi-2it  
 gi-5nj igw i-lau i-lap i-lrm i-ler j-oc k-k18 la-lx  
 m-9a smuk sad y-2ak pi-lau pi-lhr pr-4sa bam fbjo  
 hu-6clj hu-6buc hu-6est ss-2ae ic-1b hu-4a ffz.

**T. H. Harris, "Westhoek", Mintaro Avenue, Enfield, (near Sydney) N. S. W., Australia**

g-2ab g-2ao g-2bz g-2cc g-2dr g-2dx g-2fu g-2go  
 g-2it g-2kf g-2kw g-2kz g-2lz g-2nm g-2od g-2oj  
 g-2ph g-2qb g-2sh g-2sz g-2wj g-2wy g-2xv g-2xy  
 g-5ar g-5by g-5dh g-5hs g-5lf g-5ma g-5nb g-5nj  
 g-5nn g-5pm g-5qv g-5si g-5ta g-5tz g-5uo g-5uv  
 g-5uz g-5vl g-5ah g-5br g-5cf g-5fh g-5gh g-5ko  
 g-6lj g-6mj g-6nf g-6ox g-6vm g-6td g-6tm g-6ty  
 f-8bn f-8bw f-8ec f-8cc f-8cl f-8es f-8ct f-8cu f-8cy  
 f-8di f-8dk f-8ee f-8eu f-8ez f-8jr f-8gm f-8hm  
 f-8hu f-8ip f-8ix f-8jc f-8jf f-8jn f-8kf f-8kl f-8kk  
 f-8kn f-8ma f-8mb f-8nn f-8rz f-8sm f-8sz f-8tk  
 f-8tl f-8wv f-8br f-8fbh f-8gsm f-8hsf f-8lmm  
 f-8ll f-8pfp f-8pot f-8art f-8rbp f-8rdi f-8sc f-8th  
 f-8tk f-8tuy f-8wag f-8yor f-8ocng f-8octn f-8ho  
 f-8den f-8pp fm-8ma n-obq n-ocg n-ofp n-ohb n-opp  
 n-opm n-ovs n-owe n-ozn n-pb3 n-pb7 n-stb n-rdm  
 i-lat i-lau i-lax i-lca i-lce i-lch i-leo i-ldi  
 i-ler i-lfn i-lgn i-lgw i-lmt i-lno i-lrm i-lrt smnd  
 smn smz s-2co s-2nn a-lx sab sdc sgc sct ska sme  
 b-4 b-h5 b-o2 b-y2 b-z1 b-w1 b-wc b-4yz b-4zz b-2  
 e-ar1 e-ar2 e-ar2o e-ar21 e-ar23 e-ar26 v-ri r-nrl  
 r-tuk z-arl r-lf r-1nn r-1nn r-1h ka-8 k-18 k-p6 k-y5 k-y8  
 kp kw kx ei-pkl e-ldrj pk3 ctj d6n 8th p-lae p-ln  
 l-6c okl ies ezech oedj go maroc el xj o-xua ftj fua  
 fut feg flj mb6 y6 da hr gas bkn gefu gfup luv  
 9lx 9sa 9yn pe2k ybhk 8c 8cr 8px 8yx 8zc 8z6  
 ghmm ldh ghli gha ghb gbm gfc gfp byc.

**Z-2BQ, G. J. Tinney, 74 Kaimui Road, Hataitai, New Zealand**

2uo 3cdk 4bl 4ft 5aq 5lg 5agn 5ain 5ask 5auz 6bx  
 6fz 6lq 6np 6pr 6ts 6pw 7it 7kx 7vh 7aim 8ey 8sx  
 8dz 8don 8kd 8bz 8br 8che 8cd 8day 8af 8bl 8b3  
 fl hu-6bd hu-fxl ch-2ld ch-2ab ch-2ah bz-1ib bx-lav  
 bz-1bi bz-2ab bz-2bc bz-2ak r-ff9 r-bal r-c88 r-ha2  
 y-1bu y-1cg z-2co ss-8z2 b-4zz c-efl pi-lbd pi-ldl  
 pi-lhr j-lts j-3aa i-acc i-lap i-lau i-lbb i-ico i-lcr  
 i-ler i-lgw i-lrm g-2kf g-2lz g-2nm g-2od g-2bz  
 g-6td f-8octn f-8co f-8cn f-8es f-8ct f-8lf f-8fo f-8fo  
 f-8gm f-8ix f-8jn f-8kf f-8ky f-8ma f-8nox f-8tby  
 k-12 m-jh m-ln m-5c m-9a pt-lbd bam dl4 ffq oedj  
 perr.

**K. Kajii No. 100 Torisimacho, Osaka, Japan**

6adg 6adp 6agn 6akx 6alg 6air 6alt 6amm 6asa  
 6awl 6bbq 6bvy 6bhr 6bjd 6bjx 6bmv 6bq 6blm  
 6bvq 6bzm 6cgr 6ct 6cto 6eva 6db 6dca 6dl 6lg  
 6kb 6br 7it 7ms 7vh a-2bd a-2bk a-2no a-2yi a-5bw  
 a-5lf a-5wh bn-8kl bn-8k2 fi-1b fi-8tok hu-6af  
 hu-6adh hu-6ahh hu-6aj o-a3b o-a3e o-a3z o-a4z  
 o-lsr pi-lat pi-lau pi-lbd pi-ldl pi-lhr pi-3aa  
 pi-wuch ss-2se z-lax z-lao z-2bx z-4aa z-4ak.

**A. F. C. Adye, 3 Vale Avenue, Turnbridge Wells, Kent, England 40 meter band**

laae laao laay labn luci -ado lads -aff lafn  
 lafo labh laiu laja laka lakm lala lalk laiq lapo  
 lapv lapz lasf laud lauk lav lavf lavl lawe laxg



A. F. C. Adge, 3 Vale Avenue, Tunbridge-Wells, Kent, England.

laae laqa lawe laxx lazt lbec lbdq lboy lbhs 1lhb 1lbt lcaa lcaw lcxw lcjc lcjh lcim letr leu lkk 1rd lue luw lvg lvw 2aes 2ahk 2aib 2ann 2aod 2ap5 2ap2 2apv 2aqr 2aqq 2aqp 2aue 2aus 2ays 2bcb 2bs 2buv 2cep 2eg 2ejc 2eqo 2exl 2eyx 2gk 2kg 2ls 2mm 2om 2pf 2tk 2ty 2uf 2afw 2ajt 2bd 2bwt 2eeb 2eok 2hr 2ld 2nr 2zo 2ak 4iz 4sk 4lk 4oa 4pf 4qi 4rm 4tp 4wj 5aab 5fi 5he 5st 5ql 5az 5bz 5bi 5cb 5cc 5ad 5ae 5eq 5gz 5jb 5jq 5pl 9adm 9axb 9bc 9bt 9ck 9eo 9cw 9cz 9da 9ob 9oc 9z 2bk a-2cs a-2dy a-2lj a-2ls a-2sh a-2bq a-3hl a-3kb a-3ls a-3wm a-4rb a-7cw z-lax z-2aq z-2bg z-2gc z-2xa z-3al z-3ar z-4aa z-4ak z-4am y-lbp y-lbu y-led y-leg y-lcx y-lna y-2ak ch-2ab ch-3at BZ-1A laa lac lak lam lan lao lar law lab lbz lbi lqa 2ab 2ak 2ar sqi sq4 e-lar c-3dh c-9ai O-A4Z af5 a6n R1BA1 e8s hb5 bn-skl bn-sk2 cb-f2 cz-f75 tj-crj 6xc p-lay pr-4ja ss-2se bxy hvi fe-8f0 p-lbd m-ln ys-7xx. Unknown: aag abv dck npi bik.

IZL, Carlton A. Weidenhammer, 33 Washington Place, Bridgeport, Conn.

a-2yi a-3em a-5dx a-5kn a-7dx a-7dy b-4zz bz-lao bz-law bz-2ab bz-2ad bz-9qa ch-nad ear26 f-8ca f-8gm f-8rd f-oen g-2kz g-2sz g-2vq g-6nw gz-6mu g-6nf g-6td i-len i-lay m-ln m-9a n-2pz pr-4ja pr-4sa q-2lc q-8kp r-aas r-bal y-led y-lbu z-4ac z-4ag hik voq wnp.

2AYU, A. H. Fischer, 1112 North Avenue, Elizabeth, N. J.

August 3rd to October 8th

4aah 4bk 4do 4du 4f 4fx 4hl 4if 4iz 4jj 4jk 4js 4li 4lk 4ll 4nh 4ns 4oa 4ou 4oy 4pf 4pi 4pk 4pp 4ps 4qb 4rm 4si 4st 4tk 4tl 4w 4y 5ac 5ad 5adz 5afi 5ag 5aj 5aik 5ajs 5amg 5am 5aot 5api 5apo 5aqs 5bql 5ard 5aua 5ax 5er 5di 5dq 5do 5dz 5eh 5fe 5f 5ht 5iz 5ih 5il 5le 5iz 5mq 5ml 5sd 5sg 5tt 5uk 5vl 5wi 5zaf 5zai 5zaz 5adm 5akm 5anp 5bhg 5bhr 5bmw 5bpl 5bux 5btv 5bdx 5bzm 5cbj 5cbu 5cgv 5chl 5cjd 5cpl 5cqv 5ctt 5cto 5cuu 5cub 5cuc 5cd 5dd 5dgo 5do 5fz 5ge 5ha 5ih 5jn 5kh 5mb 5pw 5uf 5zat 7w bz-lam e-lld e-2ax e-3dw e-4dq ez-f75 f-8gm hu-6asd i-lau m-jh m-lj m-9a pr-4ja pr-4qe pr-4sa aat aas abl agb age av7 bb3 cb3 xc 7 fb6 fw jb.

6BUX, Walter Bolinger, 1485 East 5th Avenue, Pomona, California

lawe lboa lbox lecz lemx lf ll luw lbus 2dg 2da 2gy 2mo 2nz 2uo 2bua 2zo 2zz 4dd 4ft 4jk 4li 4ll 4mh 4oa 4ob 4rm 4si 4w 4y 5ad 5am 5apm 5bfe 5egr 5dbb 5dck 5jb 5uk 5v 5z 8aa 8ak 8al 8as 8bc 8bbx 8bus 8bxc 8cb 8ch 8cl 8dx 8dl 8el 8ew 8ex 8k 8ku 8mo 8sv pr-4uf hu-6bd hu-6buc hu-6ni z-4ak.

7GC, Geo. DeWitt Line, Sterling, Idaho September 5th to October 5th

1ab 1cz 1sr 2aar 2bbx 2bg 2ld 2es 2ev 3afu 3atu 3cl 3ea 3od 4cu 4ft 4gt 4ni 4nk 4si 4sz 4wz 4zu 4zz 5au 5af 5ahp 5oa 5ap 5arr 5bh 5ck 5ft 5hu 5ke 5sd 5sp 5vi 5wo 5zl 8aa 8ak 8al 8as 8bc 8bbx 8bus 8bxc 8cb 8ch 8cl 8dx 8dl 8el 8ew 8ex 8k 8ku 8mo 8sv pr-4uf hu-6bd hu-6buc hu-6ni z-4ak.

7NH, Paul J. Globensky, 710-5th St., Hoquiam, Wash.

laei laes lajp lamu lana laof laoh lba lba lba lbi lbi lbi lca lca lca lcj lcj lcj lcx lcx lcx ldu lej lf lf lkk lmy lwi lxy 2aa 2ah 2ah 2ah 2aib 2aib 2aib 2amq 2apd 2aqw 2avr 2awq 2br 2bz 2exl 2nf 2nz 2or 2rk 2sq 2uf 2uo 2za 2afw 3ahj 3auv 3avm 3bwt 3cc 3oc 3oj 3ekl 3iy 3kp 3pf 3tr 3w 3w 3w 3w 3w 4aa 4bt 4dd 4du 4ek 4f 4ft 4gw 4it 4iz 4jk 4li 4lk 4lt 4nf 4ob 4ob 4rm 4si 4tn 4tt 5ado 5agu 5aex 5aq 5ask 5ash 5hz 5mi 5ql 5qy 5uk 5wi 5ahc 5aia 5aj 5aks 5alk 5aly 5apm 5aul 5azh 5bb 5bbx 5bcq 5bf 5bz 5bjq 5bkm 5bpl 5bz 5ccm 5ccq 5ccr 5cdy 5eeh 5efh 5ech 5esm 5exh 5daq 5dgp 5dx 5dnp 5eb 5eq 5es 5ew 5ex 5jb 5jq 5jz 5kc 5kf 5nn 5nt 5ov 5sd 5za au-7bh au-7wm au-wwdo a-2bb a-2bk a-2cs a-2dy a-2hl a-2ij a-2mh a-2no a-2tm a-3bq a-3ef a-3em a-3en a-3kb a-3lm a-3sz a-3wm a-4an a-4cm a-5bq a-7bq 8-7cs a-7cw a-7dx a-7la a-7om a-7ow ch-2ar ch-2ld

hu-6akp hu-6asr hu-6axw hu-6est hu-6mx hu-6nl hu-6l hu-6xl j-joc m-lj m-n m-lx m-jh pi-lbd pi-lhr pr-4sa r-bal z-lax z-2ac z-2ae z-2bg z-2xa z-3ai z-3ar z-4aa z-4ac z-4am.

8BNH, W. E. Stabaugh, Jr., 142 S. Union St., Akron, Ohio

a-2bb a-2bk a-2cg a-2cs a-2lj a-2no a-2yi a-2ys a-3bq a-3ef a-3em a-3en a-3hl a-3sz a-3wm a-3yx a-5bx a-5lo a-5ma a-5nb a-5rm a-5wh a-6kx a-7cs a-7cw a-7la a-7lz b-3aa bz-2ab bz-2bc f-8ca f-8ct f-8f f-8gm f-8ix f-8jn f-8jf f-8kv f-8by f-8yor g-2kf g-2od g-2sz g-2to g-6td i-lau o-lsr o-a3b o-a4e o-a5o y-led y-2ak ys-7xx z-lao z-lax z-2ac z-2ae z-2xa z-3ai z-3ar z-4aa z-4ac z-4ak z-4am z-4av rxy.

8DCW, Wilbert Simpson, Saranac, Michigan September 27th to October 30th

6abg 6abm 6adt 6adv 6agr 6aj 6ajm 6ako 6azw 6air 6anc 6ano 6api 6are 6aut 6av 6aw 6axw 6axy 6bam 6bbn 6bch 6bhh 6bhr 6bia 6bi 6bd 6bpz 6bux 6bvg 6bvs 6bvz 6bws 6bwt 6bxd 6bxn 6byh 6bzm 6bzn 6cbj 6ccw 6cdy 6cky 6cl 6ct 6cn 6cg 6cwg 6cs 6cu 6eb 6ec 6ec 6ep 6er 6eu 6ev 6ew 6fx 6ih 6in 6eb 6ko 6mu 6py 6pv 6sz 6ts 6ul 6yb 6zat 7ag 7bz 7dd 7jf 7jk 7kn 7ob 7or 7pu 7sf 7sm 7vh 7vl 7wx.

a-3bd a-3ef a-7cw a-7dx au-wwdo b-h5 bz-lak bz-lam bz-law bz-1bl bz-2ab bz-2af bz-2ao bz-5ab bz-5ad bz-6ca bz-8q2 c-lad c-lar c-lax c-2cg c-3bj c-3nj c-3xi c-4aq c-4bb c-4du c-4hs e-2ax e-3ef c-9ai c-9aq c-9cd ch-lamf ch-2ah ch-2ar ch-2as f-8ck f-8jf f-8jn f-8mb f-8xix f-ocfn fm-2cnp g-2lz g-2od g-2xy g-5dh g-5ms gh-1fg hu-6bl hu-fxl i-lau jm-2pz m-cyy m-jh m-lj m-5c pr-4ug q-8kp r-af1 ri-bal r-d29 y-led y-2ak z-lax m-9a m-xc51 m-xc55 o-a3b o-a5e o-a50 o-lsr pr-4ja z-lax z-2ac z-2br z-2xa z-3ai z-3aj z-3ar z-4aa z-4ac z-4am aat abl agb arax av7 bb3 f8z fut fw glyk gyo ido jwh lpl m5n rxy sbl sdk sgl 4ni (qrat)

Leo Junge, 2349 Farnam Street, Davenport, Iowa

a-2bb a-2bk a-2cg a-2cm a-2cs a-2ds a-2no a-2sh a-2tm a-2yg a-2yi a-3bd a-3ef a-4an a-5kn bz-law bz-lax bz-bab ch-2ah ch-2ld ear1 f-8az f-8jf f-8jn g-2kf g-2lz g-2od g-2sz hu-6asr hu-6axw hu-6est hu-6wu hu-fxl m-lj m-ln m-lm m-9a pr-4ja q-8kp r-cb8 y-led z-lao z-lax z-laz z-2ac z-2ae z-2ga z-2xa z-3af z-3ai z-3an z-3ar z-3bx z-4aa z-4ac z-4ak a-2bm a-2cl e-3cb e-4dj e-4dm e-4dq g9y dx8 ahl bb3 xs-7qs.

P. C. Oscanyan, Operator Univ. of Mich. Greenland Expedition Near Holstenborg, Greenland July-August-September

laf lag lda ldi ldu lij llw lmd lmv lse lxx lzd lzv laao laay labt laci laff lahk lajp lakm lair laf lawy laxx lba lbez lbjx lbuz lbhs lbxz leaw leek lejx lemx lenp letp 2af 2gk 2gw 2ws 2mz 2or 2pf 2pj 2tk 2uo 2wv 2wz 2zv 2afn 2ahg 2aib 2aib 2amj 2apv 2asq 2baa 2bvg 2cc 2ejb 2vj 2xcl 2yq 2yza 3bc 3mbz 3bva 3edu 3enu 3id 3zo 4ca 4f 4gw 4it 4iv 4jk 5akn 5by 5qf 5zaf 6gf 7jf 8am 8ax 8bf 8eq 8w 8if 8im 8jq 8pk 8ar 8ahc 8alf 8aks 8ame 8aul 8axn 8bfo 8bre 8thk 8thf 8cfr 8cg 8dhw 8don 8ef 8he 8ep 8ek 8ex 8ev 8eu 8pu 8amq 8ast 8bbj 8bc 8bht 8bpd 8bna 8cej 8che 8cx 8cg 8ee 8efc 8egu 8drs 8dte 8bkl pr-4sa pr-4ja e-lar e-lld e-2be e-3am voq vyz g-2it g-2sz g-2xy g-6yd a-2co d-7xu sab su smvl rej g-6b octx ocdj fw f-5ac f-8hu f-8tis f-9cf k-12 o-hl m-8st m-un z-4ac z-2ws ch-2cx bz-lap bz-law bz-2ab bz-2aj bz-2ao bz-5a r-fb5 r-bal rxy wnp lr-6.





## Important Changes in the I. A. R. U.

**S**OME important changes have been inaugurated in the organization of the International Amateur Radio Union as a result of some months of study by the Board of Directors and the Executive Committee.

The most important one is the establishment of the policy of retaining membership dues in the treasury of each national section, instead of paying them into the international treasury at Hartford. The officers of the Union saw it as imperative that the income from dues be put at the disposal of the organized sections, in order that each section might have that money for its own operating expenses. The new system was made retroactive to May 1, 1926, and all dues paid into Hartford by members of organized sections since that date have been returned to the proper sections. Henceforth each section will collect and retain its own dues. Each section is furthermore authorized to determine for itself the amount of the dues that its members shall pay.

This provision applies only to countries where sections are organized and operating under a national president. In countries where the minimum membership strength of 25, necessary to form a section, has not yet been realized, dues will continue to be paid into international headquarters, but as new sections come into existence they, too, will operate under this provision.

A further most important change is that each organized section in the Union is now engaged in organizing itself as an independent national society. It is obligatory in many countries that organizations collecting dues have an independent identity and an independent constitution, and this fact, in addition to the logic of the action, dictates the establishment of the sections as independent associations, administering their internal affairs of dues, rules and regulations, etc., under their national presi-

dents, but remaining the I. A. R. U. member for their respective countries and cooperating in the I. A. R. U. in international matters. This will put each section on exactly the same basis that the A. R. R. L. occupies in the Union's constitution as the U. S. and Canadian Sections of I. A. R. U. In fact, this action has already been followed in France and Spain, where the *Reseau des Emetteurs Francais* and the *Asociacion E. A. R.* have been formed from the respective I. A. R. U. sections of those countries. Similar action in pursuance of the idea of the self-determination of sections is now to be expected from the remaining sections, involving the selection of a society name and the adoption of an independent constitution. Altho thus established as independent units nationally, these bodies remain none the less national sections of the I. A. R. U., the spokesman for amateur radio in their country in I. A. R. U. matters, and thus we come one step closer to the goal which the I. A. R. U. has set for itself.

The Executive Committee of the Union feels that the Union must eventually become a federation of independent national transmitting-amateur societies. That was the original idea at the time of the 1925 Paris Congress, but was found impossible of adoption because of the non-existence of bona-fide amateur societies in many countries. Since that time the Union has created and fostered closely-knit bodies of telegraphing amateurs in many of these countries, the *R.E.F.* and the *Asociacion E.A.R.* being typical examples of progress in countries where there was no nationwide association of two-way telegraphers before the advent of the Union. This change is for the future; there are many difficulties to overcome before it can come into being; perhaps we shall have to await further growth—but it is indicated now as the Union's future and is receiving the serious study of the officers.

### U. S. A. and Canadian Members

Under the terms of the above-outlined changes, the members of any society which is a part of the Union are automatically participants in the Union to the fullest extent that an individual can be. The A. R. R. L. constitutes the United States and Canadian Sections of the Union. Therefore, amateurs of the United States, Canada and Newfoundland who belong to the A. R. R. L. are *ipso facto* members of their proper section of the Union and will not hereafter be charged Union dues in addition to League dues.

The various sections are entitled to receive from the international treasury the dues paid in since May 1st last by members from their countries, and thus the A. R. R. L. would be entitled to receive the dues paid in by U. S. and Canadian members of the Union. The League, however, is leaving this money in the international treasury of the Union, for carrying on I. A. R. U. administration. —K. B. W.

**T**HE officers and Executive Committee of the Union have spent many hours studying the various problems which confront the organization. Many things have been settled, although it has taken a great deal of time, due to the fact that the officials are so widely spread throughout the world, and mail-order votes had to be secured on all matters.

### The Emblem

Suggestions for a suitable I. A. R. U. Emblem have been solicited for some time. After much consideration, the design which is reproduced herewith was adopted. Each Section of the Union is to include the name of its section in the space provided in the center of the device (Seccion Espanola, British Section, Nederlandsche Section, etc.) This design may be printed on the stationery of the Section, metal emblems or electrotypes as individual Sections desire. The emblem proportions should be such that the height of the emblem is twice its width and the height of the centerband (in which the name of your Section is to be placed) is one-fourth of the total height. It's a mighty nice looking emblem, no?



### European Assistant Secretary

By vote of the Executive Committee (I. A. R. U.) it has been decided to appoint an European Assistant to the Secretary of the Union, a man elected from the European membership who is to serve without pay. The I. A. R. U. Headquarters has re-

ceived several requests that it suggest a man and the names of W. Tappenbeck, n-PCII and Mezger, f-8GO have been mentioned. The choice is to be made by vote of the National Presidents of Sections in Europe, and any European member of the Union is eligible. It is expected that the appointee will be announced in this department in the near future.

### Bulletins

It is announced that International Headquarters will undertake the preparation of a monthly bulletin of I. A. R. U. information. The Presidents of the Sections are authorized to translate, reproduce and distribute any and all portions of the Bulletin they may desire to their respective memberships.

### Signal Strength

Although it has been in general use for some time, the British "R" system of indicating audibility on the basis of R1 to R9 until this time has not been officially approved by the Union. It has been voted that the British "R" system become the recognized means of indicating signal strength as standard I. A. R. U. practice.

### G. M. T.

By vote of the Executive Committee, Greenwich Mean Time is adopted as recommended I. A. R. U. practice for all correspondence, tests, schedules, etc. It is urged that all members adopt G. M. T. immediately in place of local time. Once the G. M. T. has been in use for a short time, the difficulties in keeping the clock straight when doing international DX work will disappear.

### Wavelengths

At the 1925 Paris Congress, certain wavelength assignments were recommended in the interests of interference elimination between different countries. The Executive Committee has carefully studied the problem and recommends the adoption of the allocation, suggested at the Paris Congress, in countries where amateurs are free to choose their own operating waves. It is urged that all amateurs in countries where existing legislation can be or is going to be modified, attempt to have transmission in their countries comply with these suggestions. The recommended bands are as follows:

Country	Lower Band	Upper Band
Europe	47.0 m to 43.0 m	115 m to 95 m
Canada and Newfoundland	43.0 m to 41.5 m	75 m to 70 m
The United States	41.5 m to 37.5 m	95 m to 75 m
The rest of the world	37.5 m to 35 m	120 m to 115 m 95 m to 85 m

### The Springbok Competition

Although the Springbok contest is over by now (by the time these lines appear in print) at the time of going to press it is



impossible to say who is the winner. At the moment 1CMX leads with 29 contacts. 6CTO being next with 21, 6BMW and 6LQ tied with 15 and 6ZAT with 14. There are a total of 81 contestants entered in the contest. FB vy. And may the lucky man win. The winner will be announced in the January issue of QST.

### Australia

The following radiogram has just been received from a2YI via 9DRD: "Since the report in August issue, conditions in Australia have been very patchy. Most nights we have had bad QRN, and generally, an hour after sunset, DX signals are only half the strength as during the hour before sunset. Most of the more powerful stations appear to have been resting up during the summer months, but a few of the Old Reliables are heard regularly and consistently. From 0530 to 0630 G.M.T. we are getting good reception of European stations. Many Australian amateurs report excellent two-way work on low power with French and other Continental amateurs. We were also expecting to hear South African stations at this time, during our winter months, but so far they have not been reported. Results from English stations using the 32-meter band are rather disappointing. They do not seem as loud as on their 45-meter wave and local QRM makes working more difficult. It is remarked that the U. S. hams are still bunched around the lower end of the 37.5-meter band, and as each night there seems to appear a fresh 500-cycle station, it is surprising the U. S. gang does not run out of the QRM. Above 38 meters the air is practically quiet. Owing to QRN we have not discovered any fresh countries yet, during our evening sessions, but hear stations in Borneo and Java operating frequently.

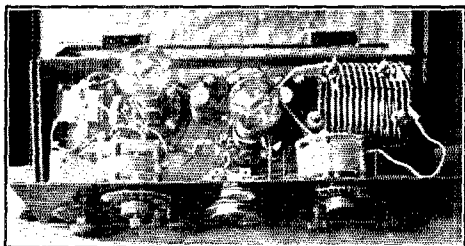

THE CRYSTAL OSCILLATOR AT a2CM

Chinese 1CRS, a five watter in Shanghai, is heard often. Much interest was shown in the detailed results of recent trans-Pacific tests, and our gang is looking forward to something more of this kind in the near future."—a2YI.

a2CM, the station of Charlie Maclurcan

of Sydney has recently been converted to crystal control. We are reproducing herewith two views of the layout. One shows the interior of the crystal oscillator cabinet which is shielded with sheet copper. The

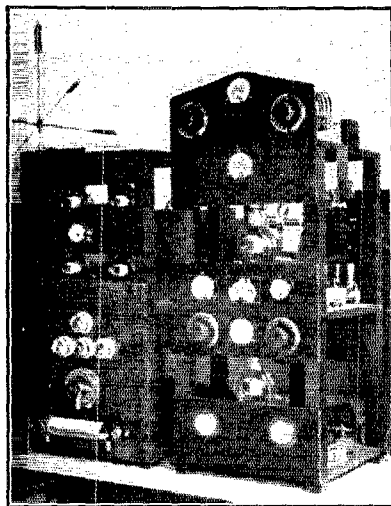

RECTIFIER AND AMPLIFIER AT a2CM

crystal mounting, crystal oscillator tube and tuning condenser appear at the left of the set. The oscillator plate inductance is a pancake one which, unfortunately does not show up very well. To the right is the first amplifier (and frequency doubler). The other photograph shows the rectifier panel (at the left) which houses four MR1 rectifier tubes which furnish 3,000 volts of D. C. to the power amplifier at the right. This amplifier panel contains two 250-watt tubes amplifying at the frequency of the preceding stage (in the oscillator cabinet). The crystal has a fundamental of 129 meters. In the first amplifier this is halved (64.5 meters) and is again halved in the first of the two, 250-watt tubes, causing the signal of a2CM to appear in the ether on 32-25 meters. Mac is anxious to know how the gang hears the new set and will appreciate QSLs.

### Austria

1BMS recently was QSOö (— — —) HL, whose QRH was 37.4 meters. 1BMS reports that 5HL comes in with an audibility of about R5, from 9 p. m. to midnight. From 9ASY we receive the calls of six active Austrian stations. The intermediate in all cases is ö and the calls HM at Wein, FS at Wein, AA at Wein, KL at Klosterneuburg, IT at Graz and GP at Wein. QSL'S to any Austrian amateur should be

sent via *Radio Welt*, III Bez, Rudengasse II, Vienna, Austria.

### Belgium

"While quite dead, as far as radio is concerned, during the late summer months, the Belgian amateurs are showing a slow but steady increase in activity. bP2 is working regular night schedules with cbF2 of Kinshasa, Belgian Congo. bU3 is now using pure d.c. on his two 50 watters and is anxious to get schedules with any of the gang on 20 meters. bCH5 has been appointed D.M. for the Antwerp District, and his dad, bB1 City Manager for Antwerp. bB9 is now in Belgian Congo keeping daily contact with his home station in Belgium and is preparing a series of schedules with Belgian friends. bS6 has been appointed D.M. for Limbourg District in place of bV2, who is now in Brussels. b4AA, who was playing with low power and a Hertz antenna all summer, has a 50-watt tube working on 44 meters and was QSO u3ACB right off the reel. bG6 has joined the Army and with a small 10-watt Army set has been QSO pr4SA."—*Paul de Neck, General Manager, Reseau Belge*

### Chile

"At Valparaiso and Vina del Mar there is a new bunch of growing hams whose first activities are being spent on fishing for DX instead of trying to QSO each other. There is a wholesale cry that a great percent of the U. S. hams make their CQs with a Creed machine-like velocity which leaves the CH newcomers in a "dit dit dah dah dit dit" condition. U. S. hams will receive many more QSL cards from Chile, and will establish many more contacts, if their speed is moderated. The following CH hams in the 2nd district are operating on short waves: 2AB, 2AC, 2AG, 2AH, 2AK, 2AR, 2AS and 2AW. Ch2AS is now on the air on 32½ meters, both c.w. and phone. Buenos Aires amateurs are picking him up in fine shape and last month sigs were heard in England. The Radio Club of Valparaiso is growing very rapidly and has a broadcasting station in operation. A short-wave transmitter has been completed, although call letters have not been assigned it yet."—A. W. Keitel, ch2AK. To which ch2LD adds that during the past month he has established the first contact between Morocco and Chile when he and fm8MA were QSO. Ch3AT is continuing to reach out in his regular DX fashion. Ch4AQ at Chance, using one 201-A tube with 220 volts of d.c. on its plate has been working many U. S. stations and established the first two-way work between Chile and Porto Rico when he QSOed, pr4SA. Ch4AQ has also worked z2AC, z1AX and has been heard in England.

### Denmark

"There are now about 35 licensed transmitting stations in Denmark, including one in the Faroe Islands (d7JO). Most of these stations use from 5 to 10 watts of power. D7MT has been QSO the U. S. with only 5 watts and has also worked Brazil. D7XU has been doing a lot of work with his new 50 watter. D7BJ is building a 100-watt crystal-controlled set (the first, we believe, in Denmark). D7ZM is operating with an input of 200 watts, under a special license. Copenhagen has had a long visit by NISS the U. S. S. *Memphis*, whose d.c. crystal-controlled set has been putting in an R10 signal into this country. Most of the amateur work is being done in our 43-47-meter band, but we are trying to get a narrow band around 33 meters for DX work, as very few DX men seem to listen around 45 meter. We usually work the U. S. between 5:30 and 7:30 p. m., E. S. T., and we usually answer a "CQ Europe" instead of calling a "CQ DX" ourselves. Reports on our signals would be very greatly appreciated as we are using low power almost entirely."—*d7JS*

### Japan

We understand that the amateurs of Japan are now applying for amateur station licenses, and that it is likely that they will be issued soon. So far, all amateur work has to be done under cover.

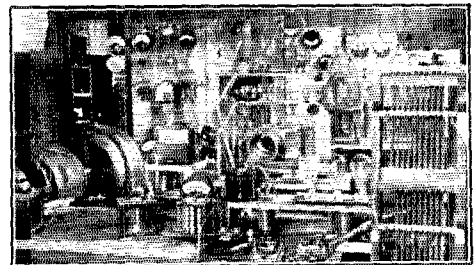

JHHB, RADIO LABORATORY, AT TOKIO JAPAN

j3AA and j3WW have applied for licenses. j3AA for five months has been using a single 5 watter and has worked South Africa, Uruguay, the sixth and seventh U. S. districts, Australia, New Zealand, Honolulu and the Straits Settlements.

From 6PW we have received the photograph of jHHB, a Government short-wave station near Tokio. This station can be heard nightly on a wavelength around 39.6 meters, with a 500-cycle note. 6PW has arranged tests with jHHB on the night of December 4th. Amateurs hearing jHHB are requested to send QSLs to E. Takagishi, Electro Technical Laboratory, Ministry of Communication, Tokio, Japan.

### Morocco

9DNG and several others report having worked fm8MA whose QRA is Cesaire Grangier, B. P. 50, Casablanca, Morocco. 9DNG also reports having worked fm8MB and fm8RA on the same night.

### WAC Club

Quite a few new calls appear in the lineup of the WAC Club. Our best DX this month is ss2SE in Singapore who has worked all six continents. The complete list of members is as follows: u60I, u6HM, u1AAO, c4GT, pr4SA, u9ZT-9XAX, b4YZ, u9DNG, pi3AA, u2APV, pi1AU, u5ACL, u5JF, g21T, gi5NJ, pi1CW, o1SR, u1CMP, u1CMX, b4RS, u7IT, u1CH, pi7BD (CD8), u6CTO, u5TW, ch9TC, 4SI-4TN, ss2SE, g5XY, ch2LD, and f8CS. She do grow! Shoot in your six QSL cards, OM and sign up.

### Lighthouse

WWDO, the U. S. Lighthouse Tender *Cedar*, in Alaskan waters, is on short waves and has been doing some nice DX work on 34.4 meters. Via radio direct to 2CRB he tells us that the ship is 100 miles west of Juneau, Alaska.

### New Ones

1BHP reports VED, Canadian Dredge No. 2, Miramichi Bay, N. B., Canada, on short waves. S. M. Chard says that the University of Siberia's short wave station TUK has changed its call to RA19. 1RF also reports VED, but gives his QRA as *S.S. Minerva*, from Bermuda QRD Halifax. Which is the correct QRA, pse? 8DCW was QSO jm2PZ, who gave his QRA as John Grinan, Kingston, Jamaica, West Indies. Is this John Grinan of ex 2PM, the pre-war whizzbang 2nd District Station? 9FI reports LA-FKA working u-8CDV. FKA QRA is at Monrovia, Liberia, on the west coast of Africa. 8CWK reports listening in on FKA-8CDV work, but got the intermediate as LI.

### Crystal Controlled Additions

The following are some of the converts to crystal control: a2CM, g2NM, u1CCZ, u4NS (ex 4NH), u3BWJ and u9SZ.

### France

The French Section of the I. A. R. U. regrets to inform all amateurs of the tragic death of our excellent fellow amateur Franz Hueber, f8DP, member of the REF and of the A.R.R.L., who met with a fatal accident while mountaineering during the holidays. Our friend was known to amateurs all the world over. We are losing in him an excellent friend and a fine operator.

There is still considerable activity among the principal French stations. On July 9th 8KF QSOed for 20 minutes with u6BAV,

which is the most difficult DX for France.

The station of f8GM has managed to QSO New Zealand when using very low power. 8GM's signals were reported R5 by six New Zealand operators. He is using the symmetrical system type circuit known in France as the Mesny circuit, with four receiving tubes having a total input of about four watts. Jamas of fl1B in Saigon, who is now on the air with a power of a few watts only, has nevertheless been heard by f8KF. This is certainly a fine low-power record. The large station f8JN has been in consistent communication with z2AC for ten months. 8JN has also kept in communication with the French cruiser *Jules Michelet* in the harbor of Shanghai. The signals from the *Jules Michelet* are heard remarkably well in France despite the fact that the transmitter on the ship is composed of six receiving tubes with a total input of about fifteen watts.

## EXPERIMENTERS' SECTION

(Continued from Page 46)

the angle at which energy leaves a vertical antenna when it is operated at various harmonics, grounded, ungrounded but near the earth and finally ungrounded and far from the earth. This covers almost all amateur requirements. Do not miss this paper.

—R. S. K.

## ~~Strays~~

### An Ow's Lament

How dreadful the life of an amateur's wife,  
Whose hubby "pounds brass" all the day;  
What storm and what strife when the  
house is all rife  
With the noise of "CQ," "QRA?"

We can hardly eat; he can hardly sleep,  
So entirely bewitched is he,  
By those little taps and those little raps,  
That are made with a radio key.

When I want him to come to a meal just  
done,  
I say, "Won't you please 'QRT'?"  
But all he can hear are the "sigs" in the  
ear,  
As he send out a "QTC?"

The dinner grows cold, and I grow bold,  
And repeat my "QRT OM,"  
But all the reply to my "QRY"  
Is "QRX" and a "QRM".

Now such is the life of an amateur's wife—  
To reform him what shall I do?  
'Tis useless to try; so with him I'll vie,  
And become an amateur too.

—Winifred Wilhite Earnhart.  
(9CHU's OW.)

# Correspondence

The Publishers of QST assume no responsibility for statements made herein by correspondents



## Practical Application

415 North Carroll St.,  
Madison, Wisconsin.

Editor, QST:

Amateur radio has served again in a very practical and efficient manner. On June 19th I sailed with my parents for a two months trip to Europe, taking a small forty-meter two-tube receiver with me in my suitcase. Before sailing, I made arrangements with an amateur friend in Madison to operate my station, 9EGH, on regular schedule every night during the trip over and back, and every Wednesday night throughout stay in foreign countries. Test messages were broadcast and home news was also sent.

With the exception of our ocean trip over and back, when receiving conditions were poor, I was able to pick up signals and copy the messages with little trouble throughout our month and a half stay on the other side. While traveling through out-of-the-way villages by auto in rural France and Germany, I received several very important business messages for my father—messages which could not possibly have been received any other way, regardless of cost, since we continually missed our mail, and there were no cable offices for many hundred miles away.

As a result of what was originally intended as an experiment only, I have concluded that this is by far the most reliable and practical means of keeping in touch with home on trips of this sort.

—R. H. Jackson, Jr., 9EGH

## Aurora Investigation

16 East 40th Street,  
New York City.

Editor, QST:

Mr. W. M. Sutton's article in the October issue on the Aurora and its effects upon radio signals opens a subject upon which concentrated and exhaustive research might well be expended. The Western Union Company, the Radio Corporation of America, the A.R.R.L. and similar organizations should

combine forces through a board of scientists paid by the commercial organizations interested to spend not less than one year in a careful compilation and analysis of data making it possible to define the relation of Aurora to radio and line disturbances.

The long lines of the telegraph and telephone companies of America are excellent means of measuring the electric energies induced at times of Aurora display. When clouds and limited vision of the sky make it impossible to say that Aurora exists, the voltages as measured in the east-west Western Union lines are a good indication of the severity of Aurora electrical storms and are measured with ease by the electricians on duty.

During the Spring of 1926, certain heavy telegraph lines leading to Western Union headquarters at New York were tied up for hours at a time. In fact for weeks Aurora disturbances handicapped routine traffic to the West almost nightly. Only once did the New York papers comment on this condition, and that after a night when even the transatlantic cables were seriously affected.

Since Aurora effects are so definitely embarrassing to the telegraph companies, and are known to affect radio communication in some manner not very definitely known, all associations and corporations likely to gain knowledge which might prove of very great worth, if not in the means for counteracting the effects at least valuable in estimating the degree of the disturbing effect of Aurora upon commercial routine, will do well to combine their resources through a central board of scientists to hasten the day when something more will be learned about the matter.

I believe the well-known unselfish energies of the officers and members of the A.R.R.L. might well be directed along lines of Aurora investigation, and that the A.R.R.L. as a noncommercial and therefore neutral body might be a means for getting the commercial bodies above mentioned to join forces with them in some manner which will reduce the time required for a general study of Aurora effects.

—Charles C. Henry,  
Sonora Phonograph Company

## Break-In With Motor-Generator Supply

597 North James Street,  
Hazelton, Penna.

Editor, *QST*:

I note that break-in when using a motor-generator for plate supply, was left out of the discussion of various forms of break-in systems described in the article "Break-In and Remote Control" in the September issue of *QST*. Like Postum, "There Is a Reason." I have tried break-in with my m.g. for some time and have at last licked the problem.

My motor-generator caused QRM to B.C.L.s within a radius of several blocks in the form of a steady "hash", making break-in at my station entirely impossible on short wavelengths. The trouble was traced to direct radiation, caused by commutation on the D.C. generator, despite the fact that the commutator was in good order and did not modulate the signal from the transmitter to any extent.

Many varieties of filter systems on either or both sides of the machine failed to remedy the trouble, and in some cases actually aggravated it. The solution was finally found in shielding the motor generator by placing it in a box lined with tin, all seams being thoroughly soldered. The tin, the frame of the machine and the negative lead of the generator were all grounded to a good ground, independent of water or gas mains. If grounded to water mains the noise was actually increased about fifty percent.

A twelve-inch hole in the top of the box, and one in the bottom, both covered with fine mesh screen also soldered to the tin lining, provided ample ventilation for the m.g. when the box was mounted several inches off the floor.

With this set-up it is impossible to tell whether or not the machine is in motion by listening on the receiver, whereas before, the QRM drowned out even the strongest signal. In the broadcast band a portable super-heterodyne receiver set right on the motor-generator box will not pick up the slightest noise from the m.g. while with the shield removed or improperly grounded, reception is out of the question a block away, even from WJZ, with the same super.

While I have my d.c. filter inside, the box along with the motor-generator, it has no effect on the QRM, whether inside or out.

—H. M. Walleze, 8BQ

### Concerning the Condenser

Villa Montezemola,  
Caletta, Livorno,  
Italy

Editor, *QST*:

The statement is made by Mr. Hatry in the July number that a small grid condenser is

desirable in order to avoid putting capacity in parallel with that of the tuning condenser. Such capacity is of course that of the grid condenser in series with the inter-electrode (grid-filament) capacity of the tube (and holder if used).

I would venture to say that the better way to reduce this parallel capacity is *not* by reducing the grid condenser (and therefore the strength of signals) but by using *no holder*, and if possible a special tube.

European tubes of the usual type average about 8 $\mu$ fd. under representative conditions and the holders anything from 5 to 40  $\mu$ fd. With the tubular type (V-24, etc.) the grid-filament capacity is too small to be measurable and the holders give 4 to 10  $\mu$ fd. I have no figures available for the American types, but as most of the capacity within the tube is in the pinch, it probably does not exceed 10  $\mu$ fd. and the holders are probably not far different from the European ones.

Taking the worst possible case, where the tube with an entirely unsuitable holder gives a total of 50  $\mu$ fd., it will be seen that the resultant capacity with a 300- $\mu$ fd. condenser will be 43  $\mu$ fd., and with the 100  $\mu$ fd. recommended by Mr. Hatry, 33  $\mu$ fd. Using the tube without holder (or probably one of the special anti-capacity holders on the market) the corresponding values would be 9.7 and 9.1  $\mu$ fd., an entirely negligible reduction, obtained at the cost of signal strength.

I suggest that, rather than reducing the grid condenser, we should *increase* it to 66  $\mu$ fd. (with a resultant capacity of 9.8 in lieu of 9.7) in order to get a slight increase in signals.

Further, it can be shown that a small grid condenser favors the detection of highly damped waves (such as many forms of QRM and QRN) and is on this account to be avoided. It also tends to produce undistorted detection throughout the audio-frequency range (and is therefore desirable for music) whereas a larger condenser tends to suppress the higher notes and is thus especially suitable for selective audio frequency detection at say 800 cycles.

—Major R. Raven-Hart, Member I.R.E., (ex CH-9TC)

### Mr. Hatry's Reply

Hartford, Conn.

Editor, *QST*:

I have read Major Raven-Hart's letter to you, and I also have a letter from him himself. In the letter he mentioned that he has done experimental work in connection with the proper sizes of grid leak and condenser, asserting that there is a measurable gain in

signal strength for the larger capacities of condenser.

Being without the laboratory equipment necessary to accurate measurement, my own determinations regarding the correct size of grid condenser are based on "ear-say". I don't know the correct size. I believe that an exact size is not necessary since above a certain degree of goodness we bump against that Chinese wall, the indifferent accuracy of the ear, which means that there will be no practical gain. Briefly my own results are such as to lead me to use consistently 40  $\mu\text{fd.}$  to 100  $\mu\text{fd.}$  as the grid condenser capacity for sets in the ordinary amateur bands. I use the smaller capacity where possible. On 20 meters and thereabouts I convinced myself that 30 to 15  $\mu\text{fd.}$  was somewhere near to what gave me the best signal strength. In the broadcast band (i.e., for 200 to 600 meters) I came to conclude on a capacity somewhere between 60 and 160  $\mu\text{fd.}$ , and I generally use 100  $\mu\text{fd.}$  Further, my ideas on the subject were assisted by some laboratory measurements not published and not mentionable with less vagueness without breaking a confidence. Here, of course, is an apparent contradiction to Major Raven-Hart; yet there is no choice but to admit that my own conclusions are not based on laboratory measurements.

The small-size grid condenser will affect the size of the tickler. When a smaller grid capacity is used the ordinary receiver will cease to oscillate in the normal fashion unless the tickler coupling is increased by using more turns or otherwise. When accidental or unintentional leakage is in a set, I know positively that increasing the grid condenser capacity will help out the volume somewhat.

I believe Major Raven-Hart entirely right regarding the capacity-reducing properties of the small grid condenser. He says in effect that it is unimportant. It is. If we have the right size of tuning condenser and have used a little care in wiring it can hurt nothing. The mention I made was simply to call attention to the fact that a small size of grid condenser did reduce the minimum wavelength of the circuit slightly.

Consultation with Morecroft's *Principles of Radio Communication* will give some mathematical figures for grid condenser if the formula given there is solved often enough, and the figures obtained will indicate the possibility that a capacity much smaller than 40  $\mu\text{fd.}$  may be useful at 40 meters. "Ear-say" convinces me that smaller than 30  $\mu\text{fd.}$  is disadvantageous. The time constants of the larger condensers indicate them to be of very doubtful advantage.

Major Raven-Hart mentions the sup-

pression of the higher audible frequencies, with the large size grid condenser he recommends. R.f. is of course of even higher frequency. At the least this looks like poor logic to defend the large condenser.

An advantage of the smaller grid condenser is that it reduces the tendency of the detector to put an audio frequency fuzz, or immature howl, on the start of oscillation, which is very annoying to the sensitive ear. Amplification of the idea in the other direction is indicated in the circuit Major Raven-Hart recommends in the latter part of his letter. An over size tickler in a normal circuit with the usual control will achieve the same result of a modulated oscillator save when the grid condenser is much smaller than 250  $\mu\text{fd.}$

This letter is no serious attempt to contradict Major Raven-Hart. His letter to you offers nothing stronger than ear-say. I am only offering ear-say. This does not settle the matter. Only a mass of confirmative evidence can—or a set of good measurements.

—L. W. Hatry, 10X

### A Comment from General Electric

1 River Road,  
Schenectady, N. Y.

Editor, QST:

It seems to be a little indefinite as to whether you are referring to the reception of modulated continuous waves or continuous waves with the detector oscillating to give a beat frequency. Most of our work on this subject has been done with modulated continuous waves and my answer will probably be confined to this phase of the subject, although perhaps the condition in the oscillating detectors is not so very different.

Mr. Smith, in the paper which appears in the latest issue of the *Proceedings* of the I.R.E. discusses the source of distortion in the detector and mentions the effects of the grid condenser. I am not sure whether he discusses this point in his forthcoming QST paper. If the grid condenser is made too small there will be a radio frequency drop which lowers the voltage at the grid. I think that most of us are inclined to underestimate the importance of this as we fail to consider the rather low input impedance of the tube when the mean potential of the grid is slightly positive, as it always is in grid rectification. This impedance may fall below 50,000 ohms in some cases so that it does not take much

(Continued on Page 65)

reactance in the grid condenser to have a considerable effect on the voltage delivered to the grid. I have never figured out the effect on the tuning circuit, but am inclined to agree with your opinion that if the grid condenser is reduced enough to lower the shunt tuning effect it must at the same time present a considerable reactance. From this line of reasoning it would appear that the grid condenser should be rather large, but as Mr. Smith points out in his paper the audio frequency reactance must be considered and this limits the capacity in broadcast reception to a point around .00025. This provides a high audio impedance up to several thousand cycles while the 10,000 micromicrofarad value which you mention would give considerable cut-off above 800 cycles.

To sum this up, it would appear that the shorter the wave-length the smaller may be the grid condenser, with considerable benefit to the higher audio frequencies and better detector action due to a higher proportion of the induced grid circuit voltage actually reaching the grid.

As regards the oscillating detector, I have practically no information and do not recall ever having seen a good treatment of the subject. It apparently is one of those things that has been over-looked by the people who are competent to give it a thorough theoretical study. It would seem to me that if the tube is oscillating weakly, as is usually the case in actual reception, the conditions may not be much different from the modulated continuous wave case. This would point to a decrease in the capacity as the wavelength is lowered. I have no experimental proof of this opinion however.

—J. C. Warner, Research Laboratory, General Electric Co.

## It Isn't Gutter Pipe

Frankfort,  
Michigan

Editor, *QST*:

On reading the good book *QST* I find that almost everyone is misnaming a very common piece of material that I am in very close contact with most of the time. Some call it "Gutter Pipe", others "Evespipe", or "Down Spout" and still others call it by the dignified name of "Roof Drain Pipe", all of which (if shot at a tinner) would hardly get you what you wanted. The correct name for all of the above is "*Conductor Pipe*". I know 'cause I am a tinner.

This Conductor Pipe can be obtained in copper as well as galvanized iron from most of the sheet metal houses. I have a 20-foot length here at my station, and I noticed that

when I installed the copper in place of the iron, the antenna current went up about two tenths of an ampere. The copper costs about sixteen cents a foot and the galvanized iron about eight cents.

I don't know whether this little information will make all the misnamers correct themselves but it would save a lot of explanations when trying to get some of the material for an aerial or mast.

—George Collier, 8CYM

## Concerning Break-Ins

Fayetteville, Ark.

Editor, *QST*:

I noticed the relays for break-in work in the September *QST* and so am sending along a photo of the dingus I made to use with 2-k.w. spark sets. It should work admirably in the system mentioned where the grid and supply circuit to the plate transformer are both opened. It is little more than a more dignified layout of the same thing as mentioned in your article.

The two silver contacts (of course they

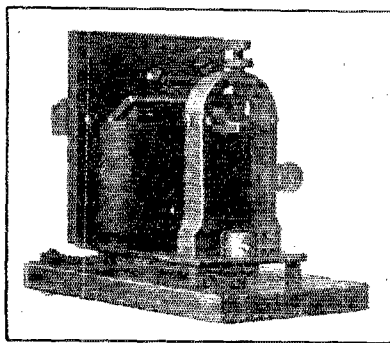

couldn't be dimes) are mounted, one directly on the armature lever, and the other, below, on the brass boss fastened to the Formica panel with a single screw through the back, allowing a degree of adjustment to that contact. On the top of the armature lever is seen a small black thing which is a piece of Formica turned down and inserted in the lever. This small knob presses against the brass spring fastened to the boss at the left. The boss at the right merely holds the brass strip which makes contact with the long strip. The screw projecting through is for adjustment. The round boss on top holds the upper contact and forms also the back-stop for the upper movement of the armature. In its original use on the spark set, this relay used the upper set of contacts to change over from receiver to transmitter, the uppermost being the antenna contact, and

the long strip the connection to the antenna through the transmitter secondary. The right hand contact was of course, connected to the ground through the ammeter. If used for c.w. work those contacts would be used for the grid break. Since the photo was made, the upper contacts have been replaced with platinum contacts.

The beauty of the whole thing though, is the way the consecutive operation of the contacts is carried out. It is seen that the strip is easily adjusted to close on the right hand contact before the main contacts are

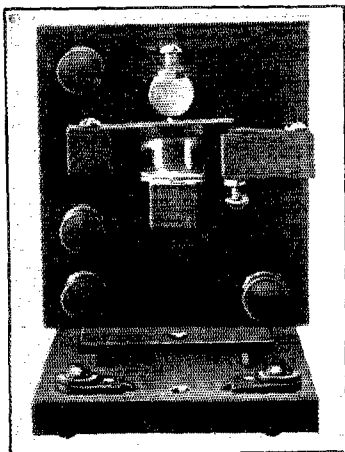

made, and that they remain closed until quite a distance separates them on breaking the circuit. An even more valuable feature of the thing is that the flat contact spring opposes the action of the armature lever spring at the rear so long as the insulating knob is against it. This can be so nicely adjusted that the entire armature is practically floating when in the upper position. This gives a very nice action when working with the "bug" as it removes the stiffness from the armature and yet allows the full strength of the main spring to be used in separating the main contacts when breaking the circuit. You know how useful this would be in working with the old 2-k.w.s, which it handles very well. The armature, floating as it is, is in motion before the auxiliary contacts let go, and the momentum carries it on, quite differently from its operation when having to start from a standstill with full main spring pressure at the back.

If I had the time now, I would give you some good, or at least passable, drawings. Oh, yes, the panel is mounted on the sounder base by means of two 8/32 screws tapped up into the panel.

—Lawrence W. Stinson.

## Micro-Micro Again

633 Lexington Ave.,  
New York City.

Editor, QST:

In your recent letter you asked me what I thought about this micro-micro business. I think pico.

It isn't a question of looking around for a new term to supplant the inexcusable micro-micro. It is merely necessary for us to begin using what we already have. The metric fathers gave it to us in the beginning, but we haven't used it for the simple reason that until now we have never had any use for a "millionth of a millionth" of anything, let alone capacity. The trouble of course dates from the fact that the creator put too much capacity into the farad, just as the same party didn't put enough b.t.u. into the kilowatt hour.

As for the possible confusion of pico with micro; I would solve that very easily. I would abolish micro along with micro-micro. I would make pico the universal handle by which to pick up capacity.

Thus balancing condensers would run from 10 to 50 picos. Low-wave tuning condensers would run from 50 to 150 picos and B.C.L. tuning condensers from 250 to 1000. Bypass condensers would run from 250 to 5,000 and blocking condensers (such as used in resistance coupling) would be of the order of 100,000 picos. Filter condensers would be of 1-, 2-, 3-, 5- and 10-million picos capacity—it is no harder to say "3 million picos" than "3 microfarads."

Once you the amateurs get to thinking in these terms for every-day fare they won't be asking you every month—"What kind of an animule is a  $\mu\text{afd.}$ " If they do ask, tell them, "It is a pico." Shortly, by repetition, a pico will become a pico, just as a spade finally became a spade.

Of course you can say "pico-farad" if you want to be nice! However I suspect you will clip it to pico shortly after getting used to it.

Whatever you do, *do something*. When QST wastes a half page, as in August, to translate micro-mikes into mikes, it seems to me that kindness to dumb animals can go no farther.

I hope these lines will make you see the light as the wise metric fathers intended you should from the beginning.

—F. I. Anderson





## KFWH AND THE TRANS-PACIFIC YACHT RACE

(Continued from Page 41)

On arrival at Honolulu the operator was extended a warm welcome by the radio fraternity there and for ten days enjoyed the hospitality of the Radio Club of Hawaii. A Lincoln Light Four to cruise about in was contributed by hu6NL. Waikiki Beach, a Luau, and a trip around the Island of Oahu were some of the many interesting features of the stay in Honolulu.

On the return trip to San Francisco, in which some 3500 miles were sailed in a little over three weeks; communication with the shore was less frequent due to heavy weather and dampness. Still there was the feeling of safety amongst the men. This was due to the reliability of the short-wave equipment as well as to the ever watchful amateur ashore.



### What Size Grid and Plate Blocking Condensers?

You have always used .002 mfd. for blocking condensers but who knows that it is the best size for short waves? Our UC 1015 condenser gives eleven different capacities between .0002 mfd. and .001 mfd. so you can select the best size for your set. Why not try them? Tested at 7500 volts.

Price \$1.25 postpaid

### General Electric Gridleaks



Enameled porcelain G. E. Gridleaks in 5000 ohm and 10,000 ohm sizes for all tubes. Size 1" x 6".

PRICES, 5000 ohm \$1.25, 10,000 ohm \$1.75, Postpaid.

Utility Radio Co., 80 Leslie St., East Orange, N. J.

## CARTER New "Midget" Rheostat

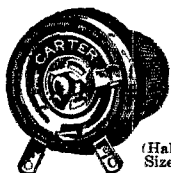

50c

(Half Size)

Smallest made. Self-Cooling all metal frame absorbs and radiates heat. No moulded parts to crack or break. Smooth, silent, positive contact. Made in all resistances, including new R.M.A. Standards. Specified in better popular circuits.

### "Midget" Rheostat with Filament Switch

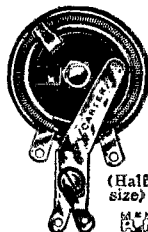

\$1

(Half size)

First and ONLY battery switch and rheostat in one. As soon as Knob is turned from "off"—the filament Circuit is closed. Eliminates one Knob from panel, simplifying operation and conserving space. A big advance in radio construction. Made in all resistances including all R.M.A. Standards.

Carter Parts are specified in all really popular circuits including Hammarlund-Roberts, LC 27, New Browning Drake, Victorean, Infradyne, etc.

In Canada—Carter Radio Co., Limited, Toronto.



\$9.00

**ADD  
DISTANCE  
AUDIBILITY  
AND  
SATISFACTION**

to your reception  
with a pair of

### GENUINE NATHANIEL BALDWIN

HEADSETS—The World's Most Sensitive Phones

Send \$9 to THE BALDWIN SALES CO., 227 Fulton St., New York City

Official Factory Repair Station—Prompt Service

# Hey, Am— Have u ordered ur copy of Handy's Handy Handbook?

THE BEST \$1 YOU EVER SPENT!

PUBLISHED BY  
AMERICAN RADIO RELAY LEAGUE  
1711 PARK ST., HARTFORD, CONN.

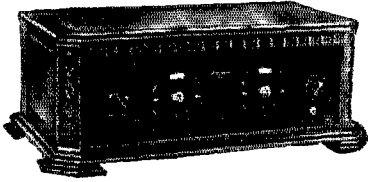

## ... how to get equal amplification

JUST below the point of oscillation is the point of maximum amplification. But how it hit this point **over the entire tuning range** has long baffled radio experts. Now it has been solved in the new Automatic Variable Coupling, which is included in the many modern features of the 1927 Hi-Q Receiver.

Through this new feature the same control operates tuning condenser and primary coil simultaneously. The result is practically an even degree of amplification—**just below the point of oscillation**—over the entire wave band. This is just one of the improvements which makes the New Shielded Hi-Q even a finer instrument than the famous Hammarlund-Roberts of last year.

Parts Complete  
(less cabinet)

**\$63.05**

The "How to Build" Book explains all features in detail.

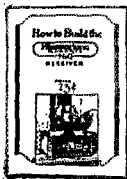

Get a copy from your dealer or send 25 cents direct.

**Hammarlund  
ROBERTS  
Hi-Q**

\*High ratio of reactance to resistance  
High ratio—Great Selectivity—Loud Signals

**HAMMARLUND-ROBERTS**  
1182-H BROADWAY NEW YORK

**American Transformer Company**

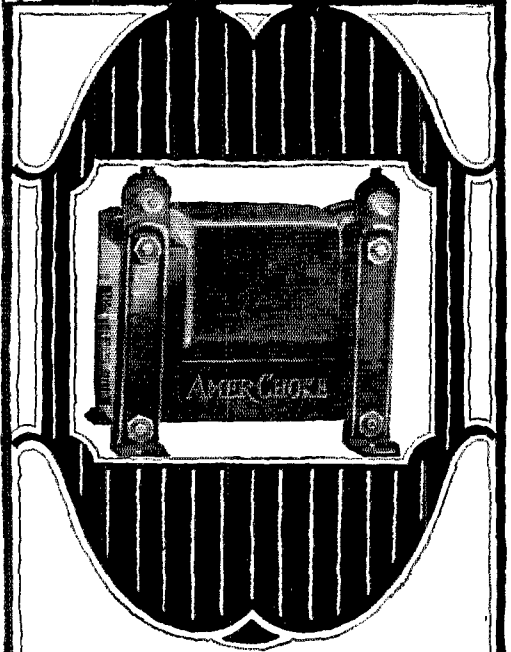

## A Reliable Choke for Filter Circuits

The AmerChoke Type 854 is a choke coil or impedance designed primarily for use in filter circuits. As an output impedance with a fixed condenser it forms an ideal filter for the loudspeaker, insuring tone quality equal to the average output transformer. And it will be more economical. For filter circuits in "B" eliminators, the AmerChoke will give perfect results due to its scientific design and generous proportions.

To obtain even, quiet current supply use the AmerChoke and the AmerTran Power Transformer (Type PF-52) in the construction of your power amplifier. Write for catalogue giving uses for all AmerTran Radio Products.

We shall be glad to send you upon request a copy of our booklet "Improving the Audio Amplifier."

**AMERICAN TRANSFORMER CO.**  
178 Emmet Street Newark, N. J.  
"Transformer Builders for Over Twenty-five Years."

AmerTran Products are Sold Only  
at Authorized AmerTran Dealers

**Transformer Builders for  
Over Twenty-Five Years**

# Making Better Radio by Shielding

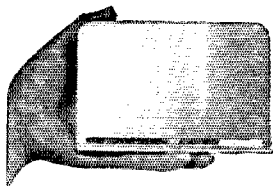

*The Alcoa Radio Shields are especially designed for insertion between stages or instruments.*

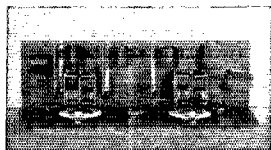

*Alcoa Radio Shields in the New A. C. Varion Receiver, marketed in kit form by the Morison Electric Supply Co., Inc., 15 East 40th St., N. Y. City.*

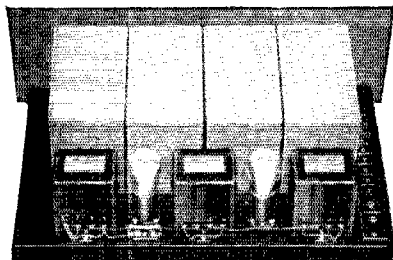

*Aluminum Shields of the can-type give total shielding to this new Silver-Marshall Receiver.*

**S**HIELDING is a most important necessity to get real radio results today. Partial shielding prevents undesired coupling, disturbing pick-up of local signals, increases distance, enhances tone quality.

Aluminum excels all other metals in shielding value. The conductivity of virgin aluminum (highest mass conductivity known), its easy fabrication, make aluminum the cheapest, as well as the best metal to use.

Any radio receiver can be shielded with aluminum with more electro magnetic efficiency, with less weight and more cheaply than with any other metal.

Interest at the radio shows was so great that we invite experts, manufacturers, constructors and amateurs to send for the new and unusual treatise on this subject by L. M. Cockaday, E. E. Free and the Research Engineers of the Aluminum Company of America. Use the coupon below.

## ALCOA



TRADE-MARK

*Only the genuine bears this mark*

**ALUMINUM COMPANY OF AMERICA  
PITTSBURGH, PA.**

Aluminum Company of America,  
Room 2322, Oliver Building,  
Pittsburgh, Pa.

Gentlemen:

Please send me a complimentary copy of the booklet "Aluminum Radio Shields."

Name.....

Street.....

City.....

What Circuit do you now use?.....

What one will you build next? .....

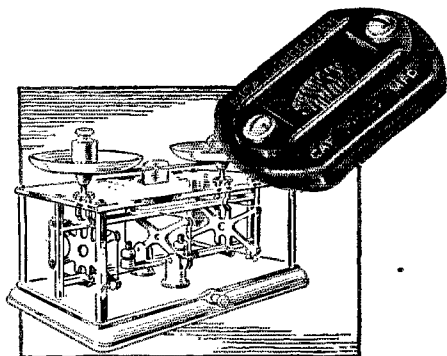

"Weights out right capacity as accurately as the apothecary weighs out a precious drug."

A. C. L.

TECHNICAL men were quick to appreciate Sangamo condensers in intermediate capacities. One engineer, well known to readers of radio publications—Austin C. Lescarbourea—sends us the following characteristic comment, which is published with his consent:

"In my laboratory we develop new circuits and variations of old circuits, publishing the results in radio magazines. Needless to say, we are using and specifying Sangamo condensers throughout. In my opinion there is no other fixed condenser that can compare with the Sangamo in accuracy, permanent capacity value, neatness and handiness.

"The Sangamo condenser weighs out just the right capacity as the apothecary weighs out a precious drug."

## SANGAMO

### Mica Condensers

are made in 34 sizes, ranging from 0.00004 mfd. to 0.012 mfd. Sangamo Wound Condensers are ready in capacities from 1/10 mfd. to 4 mfd.; Series A guaranteed for continuous operation at 250 volts AC, 400 volts DC; Series B guaranteed at 500 volts AC, 1000 volts DC; also 12 and 14 mfd. blocks.



**Sangamo Electric Company**  
Springfield, Illinois

6312-10

RADIO DIVISION, 50 Church Street, New York  
SALES OFFICES—PRINCIPAL CITIES



### Have You Tried the New OUTPUT TUBE TYPE J-71

Will handle sufficient power to operate the largest loud speakers at full volume. Does not require high voltage plate supply. At 90 volts it will give twelve times the undistorted power of the ordinary "A" type. Filament 6 vol.—1-2 amp.

PRICE  
\$4.50

The Tube  
of  
Longer  
Life

A Type  
for Every  
Radio Need

*Makes a Good Receiver Better*

*Write for Complete Data Sheet*

C. E. MFG. CO. Inc. . . . PROVIDENCE . R. I.



### APPROVED

By the critical amateur, TECO products are already world-famous. TECO is exclusively devoted to "ham" business. Our object is to give you just what you want at an economical price. May we serve you?

#### TECO SHORT-WAVE RECEIVER

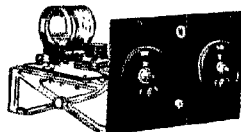

Designed by amateurs, this receiver is laboratory tested and made of the best parts obtainable. The great care exercised in its construction insures efficient operation over the entire tuning range of 10 to 30,000 kilocycles. SPECIAL SALE PRICE, \$27.50.

#### TECO SHORT-WAVE TRANSMITTER

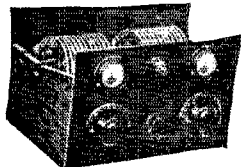

Built to the highest of standards. Has all necessary high voltage filters and chokes. A milliammeter and a hot wire meter are mounted on the panel. Two sockets in parallel give the operator complete control of the output. Tuning condensers are high voltage Cardwells. SPECIAL SALE PRICE, \$39.50.

Write for Information on Teco Plug-in Coils and Crystal Controlled Transmitter

TRANSMITTING EQUIPMENT CO., 19 Stuart St., Boston, Mass.

# WHY IS THE KARAS EQUAMATIC THE MOST EFFICIENT RECEIVER EVER DESIGNED

**Y**OU who have attended the great radio shows in New York and Chicago do not need to be told that the Karas Equamatic Receiver was not only the biggest new thing on exhibition there, but also the most talked about new receiver of either show.

Every visitor at both shows was given a new thrill when he observed how Karas had solved the last and most baffling problem of radio.

All who have heard this sensationally successful receiver—all who have built Karas Equamatics for themselves—have been amazed at its flexibility—its selectivity—its great volume—its remarkable tone, while at the same time marveling at the innate simplicity of the set and the ease with which anyone, without even a particle of radio experience, can quickly build the Equamatic and enjoy the possession of a receiver which is the last word in efficiency.

## The Hidden Secret of Equamatic Efficiency

The efficiency of the Karas Equamatic lies in its uncanny ability to maintain the tubes at their very highest point of efficiency—just below the oscillation point. Radio engineers have known for years that this was desirable, but only Karas has been able to design a receiver that accomplishes this—not occasionally—not at certain points of the dials—but AT EVERY WAVE LENGTH SETTING FROM 200 to 600 METERS! You can turn the dials of the Equamatic from one end of the scale to the other and the set will not lose one particle of its efficiency at any point. The tubes positively will not break into oscillation. Yet the slightest change in the rheostat setting will permit them to oscillate.

All of this has been achieved in the Karas Equamatic by providing a continuously equal transfer of energy between the primary and secondary of the inductance coils at all wavelength settings of the dials between 200 and 600 meters, and by making this transfer of energy at all times the practical maximum necessary to keep the tubes exactly under their oscillation point. No other set ever did this before. No other set does this now.

### Note the Three Lines on the Chart

In the chart shown above the line AA represents the oscillation point of a tube between 200 and 600 meters. The line BB, directly below this, is the point at which the tube will operate at its highest efficiency, and is also the point at which the radio frequency tubes in the Karas Equamatic operate at all wave lengths. The curved line CC indicates the tube efficiency of a tube in an ordinary tuned radio frequency set and in the neutrodyne circuit.

Note that the line CC falls far below the oscillation point at its right hand end, i. e., at low frequencies. Note also that such sets as tuned radio frequency and neutrodyne receivers approach the efficiency of the Karas Equamatic Receiver at only one point between 200 and 600 meters (this point being where the curve CC almost but not quite touches the line BB). At this one point in the broadcast wave band, and at this point only, do these sets come anywhere within range of Equamatic efficiency. If various stabilizers and other so-called lesser methods of control were not used to keep the tubes from breaking into oscillation when tuned to the shorter wave lengths the curve of these sets would extend far above the lines AA and BB, as indicated by the dotted upper portion of the line CC. Due to these lesser methods the tube efficiency of such sets at the shorter wave lengths falls away from the desired optimum line BB, at which the Equamatic System always maintains the Karas Equamatic Receiver.

Note that the left hand end of the line AA represents 200 meters, and the right hand end 600 meters, while the center represents 300 meters. Since the impedance of an inductance varies with the frequency and the amount of energy transferred from primary to secondary varies with the impedance, a primary coil must have much greater inductance to tune to 600 meters than will

be needed to tune to 200 meters. Assume that these values are 14 turns of primary for the longer wave and 3½ turns for the shorter.

### One Hundred Coils in One

The Karas Equamatic Receiver automatically provides the exact number of turns of primary for EVERY WAVE LENGTH SETTING OF THE DIALS—its ingeniously designed Inductance Coils accomplish what could only be done otherwise with a hundred separate inductances, each of the proper value for a certain wave length—and the tubes thus are kept at precisely their proper point for highest efficiency operation—just below their oscillation point. The primary coil is mounted upon the extended shaft of the Karas Orthometric variable condenser at an angle of 58 degrees, which gives, in effect, the precise number of turns or parts of a turn needed to furnish the continuously increased inductance for each succeeding longer wave length.

### What Is the Result of this Equamatic Efficiency?

As a result of its remarkable design the Equamatic has a selectivity undreamed of save in a superhot. It has a volume on DX that remains constant for every station brought in. It has a clarity of tone that is unlike any other receiver, regardless of price or number of tubes. It is easy to tune. Any member of the family can get superlative results with the Equamatic. It stays put—does not develop temperamental streaks—has no "off nights"—and performs consistently and uniformly at 100% efficiency always.

### You, Too, Can Build This Great Receiver

Anyone, even without set-building experience, can build this wonder set in a short time. We furnish a complete manual of simple, easily understood assembly instructions with every set of three Karas Equamatic Inductance Coils. We supply every nut, screw, binding post, for mounting all the parts. In addition to the Karas parts listed in the coupon you will need certain other standard parts easily obtainable anywhere. Your dealer can supply ALL of the parts you will require, including panel and subpanel completely drilled and engraved, if you wish. If he is out of stock you may order Karas parts direct from us by filling out and mailing the coupon below. SEND NO MONEY. Just hand the postman the price of the Karas parts plus a few cents postage.

Order your parts today so that you can begin building your Karas Equamatic Receiver just as quickly as possible. You want one of these great sets—you should have the most efficient receiver obtainable—you will have it if you build this Karas Equamatic. MAIL THE COUPON NOW!

### KARAS ELECTRIC CO.

1039 Association Bldg., Chicago

Equamatic System Licensed under King Patents Pending.

Karas Electric Co.  
1039 Association Building  
Chicago, Illinois

Please send me set of 3 Equamatic Inductance Coils, \$12.00; 3 special Orthometric Condensers with extended shafts, \$7.00 each; 3 Micronetric Vernier Dials, \$3.50 each; 2 Harmonic Audio Transformers, \$7.00 each; 2 Equamatic Retard Coils, \$1.00 each; and 3 sub-panel brackets, 70c, for which I will pay postman \$60.20, plus postage, upon delivery. It is understood that I have the privilege of returning any of this apparatus for full refund any time within 30 days if it does not prove entirely satisfactory.

Name .....

Address .....

City ..... State .....

(If cash accompanies order we will ship postpaid.)

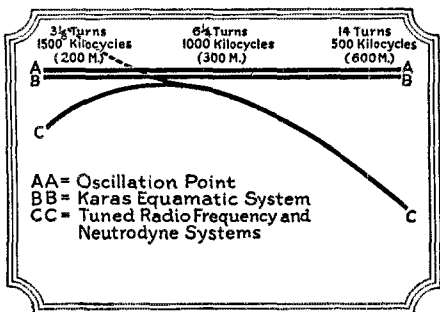

AA= Oscillation Point  
BB= Karas Equamatic System  
CC= Tuned Radio Frequency and Neutrodyne Systems

**KARAS ELECTRIC COMPANY**

1039 Association Building, Chicago.

SAY YOU SAW IT IN QST—IT IDENTIFIES YOU AND HELPS QST

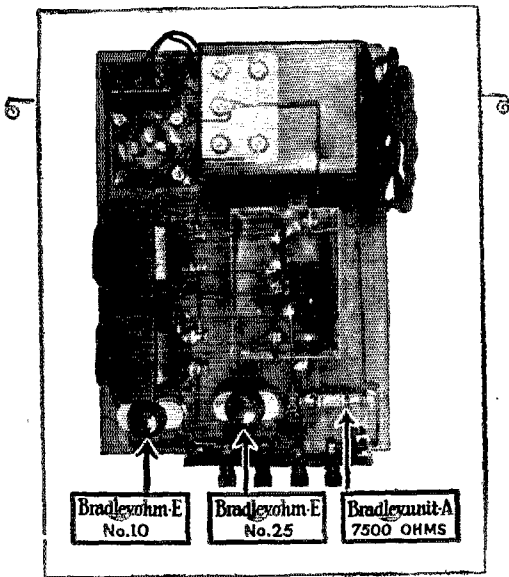

## What a whale of a difference a few Bradleyohms make —in a B-Eliminator!

THE leading manufacturers of B-eliminators all use Bradleyohm-E for plate voltage control as standard equipment in their B-eliminators. Leading radio authorities specify the use of Bradleyohm-E and Bradleyunit-A in B-Eliminator kits. There



Bradleyohm-E perfect variable resistor

You then will be assured of perfect plate voltage control which is so essential for radio sets operated with B-eliminators.

Send for folder entitled "How to Build a B-eliminator" describing 7 popular hookups.



Bradleyunit-A perfect fixed resistor

Allen-Bradley Company  
277 Greenfield Ave., Milwaukee, Wis.

Use  
**Allen-Bradley**  
Perfect Radio Devices

# Makes Any Set a New Set in 15 Minutes!

Bring your set up-to-date. Make it more sensitive and selective so you will get ALL the stations. Install

## METRALIGN SLT STRAIGHT LINE TUNING

condensers in place of your old ones and set an even spread of all stations. Write for booklet.

**GENERAL INSTRUMENT CORP.**  
477 Broadway,  
New York  
City

PATENTED



## 635 Short Wave Kit

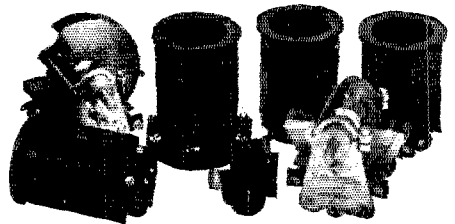

Deep in the unexplored tropics of South America—with Commander Dyott's expedition to the River of Doubt—a short wave receiver built around the S-M 635 Kit is doing its stuff, supplied and recommended by Radio Broadcast. Need more be said about the "sure fire" dependability of this remarkable Short Wave Assembly?

The S-M 635 kit consists of four coils, a coil socket, two short wave condensers, and an antenna condenser. The price is \$23.00. Or you can buy the four plug-in coils alone, covering the 18 to 150 meter range with any standard .00014 condensers, for \$11.00 if you just ask your dealer for a No. 117 short wave coil set.

Price \$23.00 at Your Dealers

**Silver-Marshall, Inc.**

858 West Jackson Blvd.

Chicago, U. S. A.

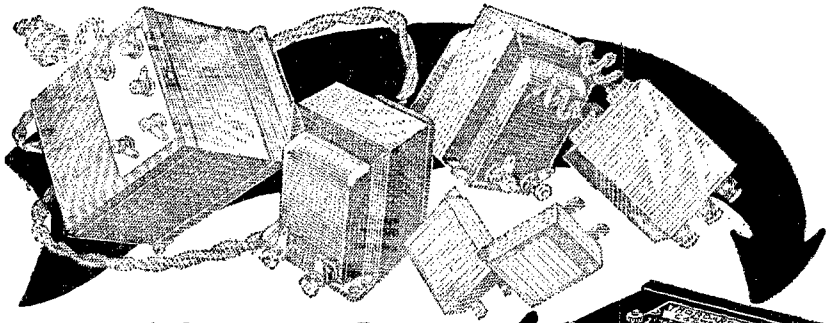

*All in One!*

**THORDARSON  
POWER  
COMPACT**

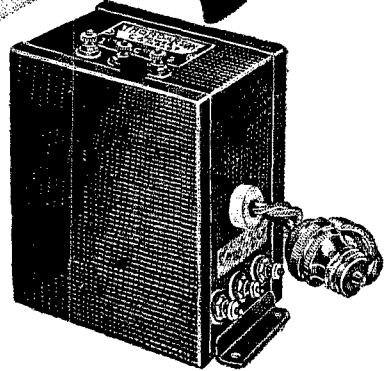

**TYPE R-171**  
For Raytheon BH rectifier  
and power tube UX 171.  
Includes buffer condensers.  
\$15.00

**TYPE R-210**  
For UX 216-B type rectifier  
and power tube UX 210. In-  
cludes no condensers.  
\$20.00

**The Complete Foundation Unit  
— for —  
power amplification & B-supply**

**Simplified Assembly.** Only 14 leads are necessary to complete the Raytheon assembly. All terminals are carefully located for the greatest ease of connection.

**Compactness.** The only additional apparatus required to build the B-supply are the condenser block (Raytheon type), a Raytheon tube BH, and the resistance units.

**High Efficiency.** The power supply of either Power Compact furnishes the proper current for maximum efficiency of the rectifiers used; the chokes are of sufficient capacity to carry the maximum output. Conservatively rated; will not heat up in continuous service.

**High Voltage Output.** The R-171 Power Compact assembly will deliver a maximum plate voltage output of 300v. at 30 MA., or 275v. at 40 MA.

**A power supply transformer  
2 filter chokes  
A power filament supply  
2 buffer condensers**

**ALL IN ONE CASE**

The R-210 type assembly will deliver 400 volts to the plate of the power tube, and, in addition, will supply a constant 90 volts to the receiver

at any current drain up to 40 MA.

**Silent In Operation.** There is no traceable hum, either mechanical in the compact itself, or electrical through the loud-speaker.

**Complete Supply For Power Amplification.** The Power Compact provides for complete A-B-C supply for the power stage. **Makes it possible to use power amplification even on sets designed for dry battery operation.**  
**Electrical Centered Filament Supply.** The power tube filament supply is **tapped at the exact electrical center for grid return.** The center tap is taken from the common lead of two perfectly balanced windings—completely obliterating the A. C. hum. (An exclusive Thordarson feature).

Write for instruction booklets SD-49 and SD-50  
If your dealer cannot supply, order direct from factory

**THORDARSON ELECTRIC MANUFACTURING CO.**  
*Transformer Specialists Since 1895*  
**WORLD'S OLDEST AND LARGEST EXCLUSIVE TRANSFORMER MAKERS**  
*"Luron and Kingsbury Streets" - Chicago, Ill., U.S.A.*

246-A



# YAXLEY

APPROVED RADIO PRODUCTS

## Automatic Power Control

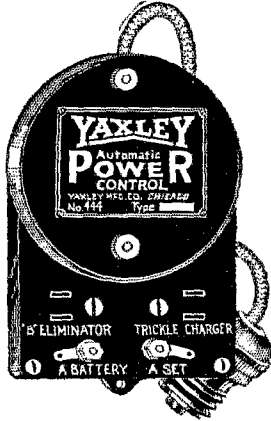

No more plugging in sockets and turning several switches every time you use your set. No more pulling out plugs from sockets and turning off switches when you turn off the set. No more needless burning of lamps which reduces their usefulness, and runs down your battery.

These are some of the things the Yaxley Automatic Power Control will do for you. It does all the extra switching. It takes care of your B eliminator or trickle charger or both. When you turn the switch on your set, the trickle charger is off, the B eliminator is on. When you turn the set off, the Power Control is standing guard for you. It works automatically, surely and without fail to turn off the B eliminator and turn on the trickle charger.

**No. 444**—Automatic Power Control, Series Type—for use with sets having tubes with a current draw equal to or greater than 6 U.V.-199-type Tubes .....Each, \$5.00

**No. 445**—Automatic Power Control, Multiple Type—for use with any set, but especially for sets having tubes with a current draw lower than that of 6 U.V.-199-type Tubes Each .....\$6.00

*At Your Dealers. If he cannot supply you, send his name with your order to*

**YAXLEY MFG. CO.**  
Dept. S, 9 South Clinton Street  
Chicago, Ill.





*"Built Better"*

## FIXED CONDENSERS

are Specified in

**LC ~ 27** by L. M. Cockaday  
 Diamond of the Air " Herman Bernard  
*To be announced soon(?)* " John Rider  
 Raytheon "B" Eliminator " Raytheon Mfg. Co.  
 Ultra-dyne " R. E. Laeault  
*To be announced soon(?)* " R. E. Laeault

AEROVOX fixed condensers have been approved by M. I. T. and Yale Universities.

**AEROVOX WIRELESS CORP.**  
489-491-493 Broome Street, New York

# 5 tube SINGLE DIAL Control \$75

CONSOLE MODEL 5 tube 5-75 Single dial control with graphic drum station selector. A mahogany cabinet, two-toned finish, into which is built the famous Crosley Musicone, cleverly concealed behind a silk screen. Cabinet will hold batteries and accessories. Stands 40 inches high. Rose gold trimmings. Price slightly higher west of Rocky Mountains.

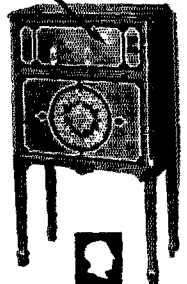

**CROSLEY RADIO**  
CROSLEY RADIO CORPORATION  
CINCINNATI

Licensed Under Armstrong U. S. Patent No. 1,113,149  
Write Dept. 18 for Catalog



Look  
in the  
magnifying  
glass!

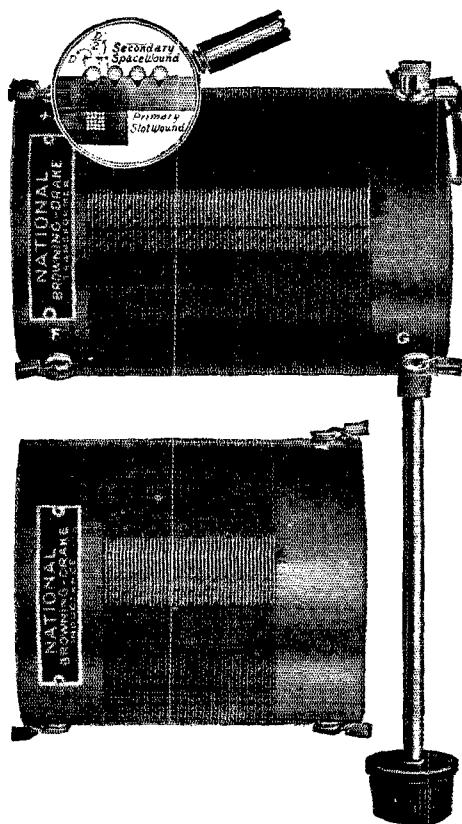

You can see 2 reasons why  
**NATIONAL BROWNING-DRAKE**  
Inductances and R. F. Transformers perform so  
consistently well.

- 1 SLOT-wound primary, making for minimum capacity coupling between primary and secondary.
- 2 SPACEWOUND secondary, for best selectivity and lowest R. F. resistance. Developed mathematically by Glenn H. Browning and F. H. Drake, at Cruft Laboratory, Harvard University, after a year of research, and made under the personal supervision of Mr. Browning.

These are the coils and transformers used on the famous NATIONAL tuning units,—which also embody the NATIONAL "EQUICYCLE" Condensers and the universally used NATIONAL VELVET-VERNIER Dials. These last are now made as the ILLUMINATED Dials Type C.

NATIONAL CO. Inc., 110 Brookline St., Cambridge, Mass.  
Engineers and Manufacturers — W. A. Ready, Pres.

BE SURE YOU GET GENUINE

**NATIONAL**  
**RADIO PRODUCTS**

SAY YOU SAW IT IN QST—IT IDENTIFIES YOU AND HELPS QST

# YOU NEED THESE PLUG-IN COILS

Note the many advantages of these better and different coils listed below and try to do without them

1. Positive contact is secured through General Radio plugs and jacks.

2. With 3 Coils, continuous, gapless range is secured from 140 to 16 meters. One of the 20-40-80 meter amateur bands is located in the middle of the tuning range of each of the 3 coils. (For this a SFL Condenser, 140 mmfd. max. cap. is essential.)

3. Operation of regeneration condenser has no effect on the tuning; the 2 controls are completely independent.

4. Antenna coupling is adjustable; by a primary coil

and not through a condenser. Secondary coils are specially constructed so that setting of primary coil does not need to be changed when secondaries are exchanged.

5. Coils are space-wound solenoids on skeleton frames.

6. Both tickler and antenna coil are at filament end of the secondary.

7. These coils cover the 3 U. S. Amateur Bands, all European Amateur Bands, Short - Wave Broadcast, U. S. Naval and Commercial Short-Wave Stations, etc.

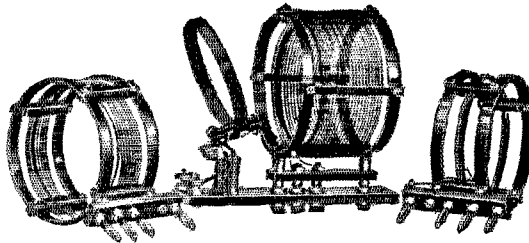

The Kit Illustrated Covering 15 to 133 Meters Complete \$12.50

Coil No. 4, 125-250 M  
Price \$4.00

Coil No. 5, 235-550 M  
Price \$4.00

These coils are essential to the most efficient operation of your station. Order yours TODAY.

**AERO PRODUCTS INCORPORATED, Dept. 16, 1768-1772 Wilson Ave., Chicago, Ill.**

## GENUINE BAKELITE PANELS 1/4" THICK

First Grade. Highly Polished on Both Sides

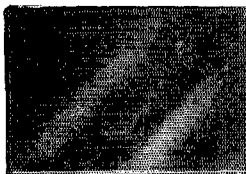

Size	Regular Price	SPECIAL PRICE
9 1/2 x 11 1/8"	\$2.63 ea.	\$1.00 ea.
10 1/16 x 14 1/16"	3.63 ea.	1.50 ea.
14 9/16 x 17 15/32"	6.38 ea.	2.50 ea.
14 9/16 x 17 1/2"	6.63 ea.	2.60 ea.
15 1/4 x 17 1/8"	6.63 ea.	2.60 ea.
15 1/8 x 16 13/16"	6.38 ea.	2.50 ea.

Make your TRANSMITTER and RECEIVER efficient and neat with these High Grade Panels.

AMERICAN SALES CO., 21 WARREN STREET, NEW YORK CITY

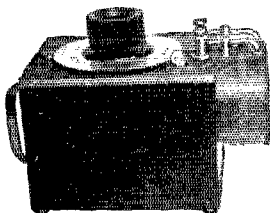

### LOOK!

THE  
NIFTIEST  
AMATEUR  
WAVEMETER  
MADE

COMPACT, RUGGED, DEPENDABLE  
ACCURATE  
JUST WHAT YOU NEED!

Bulletin A tells the rest. Write for it.

SEATTLE RADIO LABORATORY  
3335 33d Avenue, South Seattle, Wash.

## RADIO OPERATORS WANTED

THE EASTERN RADIO INSTITUTE can train you quickly and thoroughly because:

MODERN AND EFFICIENT METHODS  
THOROUGH INSTRUCTION under staff of  
LICENSED COMMERCIAL OPERATORS  
MODERN APPARATUS including SHORT WAVE  
TRANSMITTER

FOURTEEN years a RADIO SCHOOL  
THE OLDEST, LARGEST and MOST SUCCESSFUL  
school in New England. RECOMMENDED BY THE  
A. R. R. L.

Day or Evening Classes Start Every Monday.

SPECIAL CODE CLASSES

Write for Illustrated Prospectus

**EASTERN RADIO INSTITUTE**  
899 BOYLSTON STREET BOSTON, MASS.

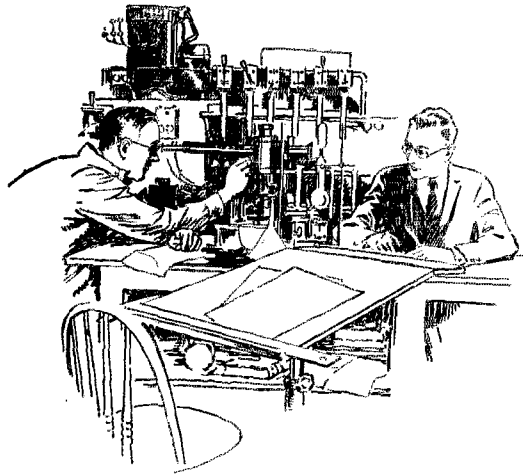

# A \$20,000,000 IDEA



## "Approved by Raytheon"

- Manufacturers of Complete B-Power Units, Raytheon-equipped:
- Acme Apparatus Co., Cambridge, Mass.
  - All-American Radio Corp., Chicago, Ill.
  - Amer. Bosch Mag. Corp., Spring'd. Mass.
  - American Electric Co., Chicago, Ill.
  - Apco Mfg. Co., Providence, R. I.
  - Cornell Elec. Mfg. Co., L. I. City, N. Y.
  - Electrical Research Labs., Inc., Chicago.
  - General Radio Co., Cambridge, Mass.
  - Grigsby-Grunow-Hinds Co., Chicago, Ill.
  - Kink Elec. Mfg. Co., Buffalo, N. Y.
  - Kokomo Electric Co., Kokomo, Ind.
  - Moyolian Radio Corp., Bronx, N. Y.
  - The Modern Elec. Mfg. Co., Toledo, O.
  - Pathe Phonograph Co., Brooklyn, N. Y.
  - Sparks-Withington Co., Jackson, Mich.
  - The Sterling Mfg. Co., Cleveland, Ohio
  - Storad Mfg. Co., Cleveland, Ohio
  - J. S. Timmons, Inc., Germantown, Phila.
  - Valley Electric Co., St. Louis, Mo.
  - The Webster Co., Chicago, Ill.
  - Zenith Radio Corp., Chicago, Ill.

TEN YEARS ago Charles Grover Smith began the intensive study of the possibilities of handling electrical power by gaseous conduction. With the resources of the Raytheon Research Organization behind him, he produced the Raytheon Rectifier, giving for the first time full wave rectification with simplicity, long life, and absolute reliability, and making possible in the one year since its introduction, a business in Raytheon-equipped B-Power units of approximately \$20,000,000.

Raytheon has many ideas. For their development Raytheon maintains a Research Organization housed in a separate building, and with a staff headed by such men as Mr. Smith, Dr. Vannevar Bush of M. I. T., Monsieur Andre of the La Radio Technique of Paris, Mr. J. A. Spencer, inventor of the Million Dollar Thermostat, and many others. The equipment at their disposal cannot be duplicated anywhere. It is little wonder that those close to radio power problems look to Raytheon for their most effective solution.

RAYTHEON MANUFACTURING COMPANY  
Cambridge, Massachusetts



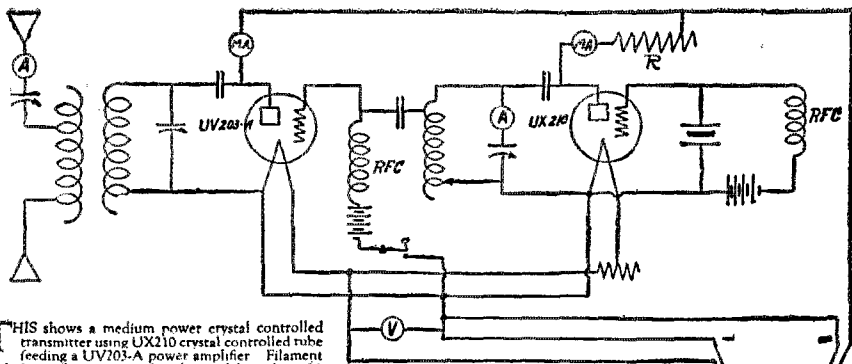

THIS shows a medium power crystal controlled transmitter using UX210 crystal controlled tube feeding a UV203-A power amplifier. Filament and plate voltages are to be obtained from item 34, operating from either DC or AC house mains. The voltage to the filament of the tubes is variable, either by the field rheostat in the filament generator circuit (not shown) or by the resistance in the filament circuit of the UX210 tube. Keying is done in the bias circuit of the 203-A power amplifier. As the amplifier is NOT neutralized, the power amplifier must work on some harmonic of the crystal tube (preferably the second), for all operations in the 20, 40 or 80 meter bands. A crystal having a fundamental of 160 meters will allow operation in all bands with best output in the 80 meter one. An 80 meter crystal is best for 40 meter operation and in like manner the 40 meter crystal would be best for 20 meter operation. Forty meter crystals are hard to get and blow up easily, so for 20 meters the 80 meter crystal is used again. Both tubes obtain plate supply from the plate end of item 34, the UX210 being supplied with not over 350 volts through resistance R, and the 203-A taking the full 1000 volts.

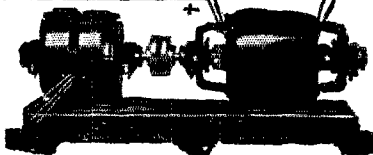

## ELECTRIC SPECIALTY COMPANY

150 South Street

TRADE "ESCO" MARK

Stamford, Conn., U.S.A.

Manufacturers of Motors, Generators, Motor-Generators, Dynamotors and Rotary Converters for Radio and other purposes

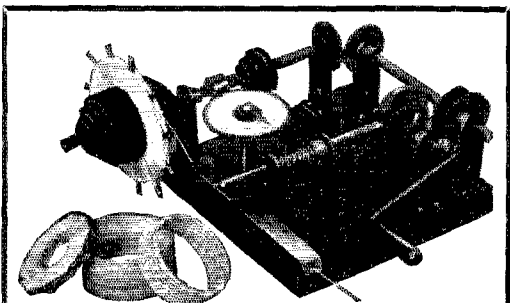

**Morris Universal Coil Winding Machine**  
The one machine that winds them all, Spider-web, Honeycomb, solenoid and others, PRICE \$7.50.  
MORRIS REGISTER COMPANY, Council Bluffs, Iowa

## Broadcasting Station Accessories

Push-Pull Transformers for 7½ w. 50 w. and 250 w. speech input circuits.

Microphone Mixing and Amplifier Output Transformers. A complete line of retards and transformers for amplifier circuits.

Variable and Fixed Air Condensers of any size required.

High voltage Plate Generators up to 30 k. w.

Broadcast Station erecting, rebuilding and general engineering.

**J. E. Jenkins & S. E. Adair, Engrs.,**  
1500 No. Dearborn Parkway, Chicago

## THIS IS A PLAIN BUSINESS TALK.

There were certain grave drawbacks in all forms of the old keys. Some persons NEVER could learn to use a standard key—much less other forms. Some never could learn to use these WELL. They had BUM FISTS. The keys produced GLASS ARMS. It took months of practice to master some keys and years to master others. Beginners could not learn to READ CODE without some one to send for them. There was an insistent demand for a key which would do away with these difficulties. One who had invented some score of articles took up the matter and working and studying for more than a year under the direction and criticism of a radio operator perfected

### THE CRICKET KEYS

which do away with all these evils—"the greatest advance in radio since the vacuum tubes." They everywhere receive hearty praise. They are destined to be the popular keys.

We guarantee workmanship and material and that with even ordinary intelligence they will do all that we claim for them. Highest quality combined with moderate price.

#### Desk CRICKET

Brass contact, \$9.00 prepaid  
Silver contact, \$10.50 prepaid.

#### Portable CRICKET

Brass contact, \$10.25 prepaid.  
Silver contact, \$11.75 prepaid.



Listen to 5EH

DESK CRICKET

Hams' Delight and Beginners' Best Friend.

**F. F. MACE & SON, 132 Sunset Ave., Dallas, Texas**

# New

**.0001** m. f.  
maximum  
capacity

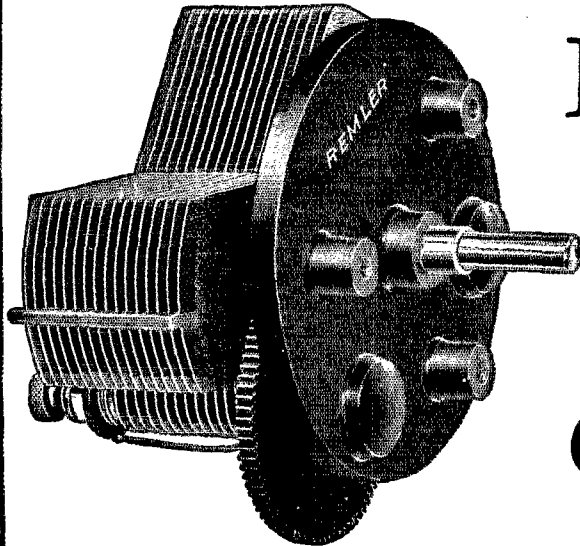

## REMLER

TWIN-ROTOR

*Straight-Line  
Frequency*

## Condenser

*Specially designed for short wave reception*

Its immediate popularity is not only in its improved design, but in the new standards of perfection it brings to radio reception. A straight-line frequency type condenser of .0001 maximum capacity, and as low as .000001 minimum. Full 360° movement, and special zero dial setting allows still further spreading of stations.

Superior design is proven in every feature—back lash eliminated by a spring acting against one of the rotors—brass plates specially crimped and aligned by hand—pigtail connections throughout—dielectric losses and body capacity effects completely eliminated.

Superiority that needs no further proof—just try it!

**Price \$4.50**

*Write for complete descriptive folder.*

**REMLER**  
GRAY and DANIELSON  
Manufacturing Company



CHICAGO

260 FIRST STREET • SAN FRANCISCO

NEW YORK

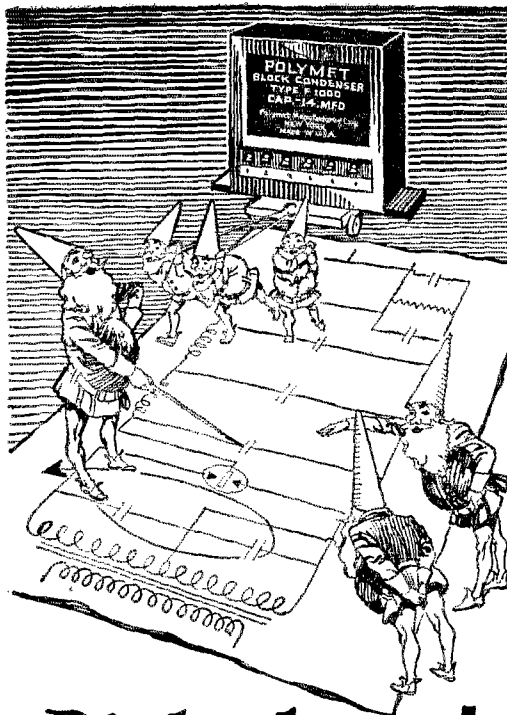

# Right here!

You can't go wrong when you use Polymet High Voltage Condensers in sets or power units. Built to withstand 1,000 volts permanently, and individually tested for this rating, their obvious superiority, both in workmanship and in performance, definitely establishes Polymet's leadership as condenser manufacturers.

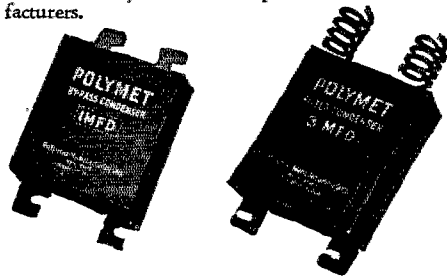

Obtainable as individual units or in blocks; in cans or unmounted; with fixed or flexible leads.

Capacities .1 to 5. Mfd. . . . 60c to \$4.50  
**RAYTHEON CIRCUIT BLOCKS**

F1001 1-C. 1 Mfd. . . . \$2.00  
 F1000 14 Mfd. . . . . 9.50

Follow the manufacturers—specify Polymet Products—at all good dealers. Illustrated descriptions sent FREE on request.

**Polymet Manufacturing Corporation**  
 599 E. Broadway New York City  
 "World's Largest Manufacturers of Radio Essentials"

# POLYMET

# ADVANCE

## "Sync" RECTIFIER

*the favorite with amateurs*

Although lower in price, the ADVANCE Sync Rectifier is far superior in quality—as proven by its prevailing use in international transmitting. It actually does what other rectifiers claim to do. Meets all requirements for heaviest duty. Can be easily and quickly filtered. Speedy starting because of Advance Bakelite wheel. Requires no attention—always ready.

Revolving disk is moulded bakelite six inches in diameter. Nickel plated brush holders with adjustable gauze copper brushes.

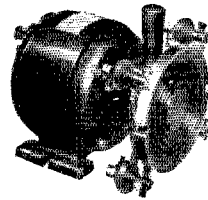

Convenient control handle. Disk, aluminum brush arm support and brush holders perfectly insulated.

Price complete with Westinghouse 1/4 H. P. Synchronous Motor . . . \$40  
 Rectifying wheel with complete brush assembly and mounting ring to fit your own motor . . . \$15

We Pay All Transportation Charges in U. S. A.  
**ADVANCE ELECTRIC COMPANY**  
 1260-1262 West Second St., Los Angeles, Calif.

# LYNCH

## METALLIZED

**WARRANTED FIXED RESISTORS**

THE vital importance of a silent, accurate resistor cannot be overestimated. Comprising a concentrated metallized deposit one-thousandth of an inch thick, upon a glass core and sealed forever within the tube, each Lynch Resistor is warranted absolutely noiseless, permanently accurate, dependable! Guaranteed accuracy—10%; in production they average 5%. .25; .5; 1; 2; 3; 4; 5; 6; 7; 8; 9; 10 Meg., 50c. .025; .09; .1 Meg., 75c. Single mounting 35c; Double, 50c. If your dealer cannot supply you, send stamps, check or money order. We ship postpaid same day order is received.

Dealers—Get on our mailing list; we keep you posted on new developments. Write us today!

ARTHUR H. LYNCH, INC. MEMBER **RMA** 426 Q  
 250 W. 57th St. New York, N.Y.

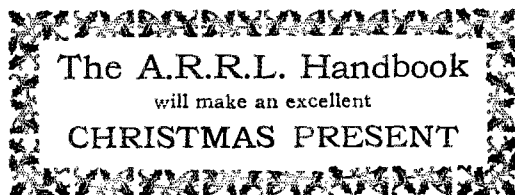

The A.R.R.L. Handbook  
 will make an excellent  
**CHRISTMAS PRESENT**

# AMATEURS

Standardize on

# GENERAL RADIO

Apparatus in Your  
Short-Wave  
Receivers and Transmitters

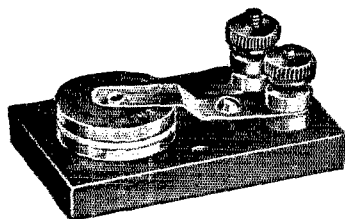

### Type 276-A—Quartz Plates

Quartz plates for crystal controlled transmitters are available at random frequencies in the 150-170 meter band. These plates provide harmonics in the 20, 40, and 80 meter bands, and may be used for transmitters on these wavelengths. Calibration is to 0.25%. All plates are guaranteed to oscillate when used as directed. The only licensed plates available to amateurs.

Type 276-A Amateur Quartz Plate, unmounted, \$15.00  
Type 356 Crystal Mounting, 1.00

### Type 358—Amateur Wave Meter

This instrument is particularly designed for amateur use in checking wavelengths. Consists of a coil mounting directly on the binding posts of a shielded condenser of 125 MMF capacity. A small lamp serves as a resonance indicator.

The 358 wavemeter is supplied with 4 coils, a calibration chart and wooden carrying case.

The coil ranges are as follows:

Coil A .....	14 to 28
Coil B .....	26 to 56
Coil C .....	54 to 114
Coil D .....	105 to 224

Wavemeter complete ..... Price \$22.00

### Type 349—UX-CX Tube Socket

This socket is made of moulded Bakelite and designed for UX and CX base tubes. Positive contacts are made with double gripping springs of Phosphorus bronze to the sides of the tube prongs.

Type 349 Socket ..... Price \$5.00

### Type 334—Transmitting Condensers

The types 334-T and V condensers are similar in appearance and assembly to all other Type 334 condensers except that they have double spacing for use in short wave transmitting on voltages up to 2000. They have metal end plates with shielded rotor. Plates of the rotor and stator groups are soldered to insure perfect electrical contact. The type 334 transmitting condensers are supplied with counter weights only.

Type 334-T Capacity 100 MMF Price \$4.25  
Type 334-V Capacity 50 MMF " 3.75

### Type 277—Low Loss Coils

The type 277 coils are wound on moulded Bakelite forms, and the ratio of diameter to length so proportioned that they have very low losses. They are available in various ranges of wavelengths from 50 to 900 meters, and are supplied with single winding and with primary and secondary windings closely coupled. For ranges and prices, see Bulletin No. 925.

Write for Folder 276-A on Quartz Plates and Parts Bulletin 925-A

**GENERAL RADIO CO. :: CAMBRIDGE, MASS.**

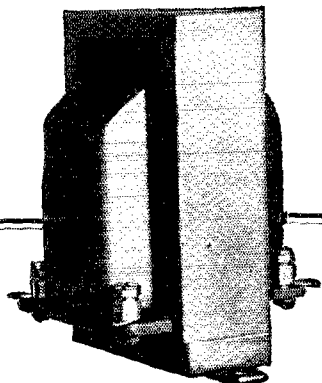

## Audio Frequency Transformers

Every note of the entire musical range—from the highest to the lowest—is brought in with its natural, unmarred tonal beauty with the

### PACENT SUPERAUDIOFORMER

INPUT TYPE No. 27A, Ratio 3 to 1, Primary Inductance 124 henrys, designed for use between any vacuum tubes.

Shielded \$7.50 Unshielded \$6.00

OUTPUT TYPE No. 27B, Ratio 1 to 1.

Shielded \$7.50 Unshielded \$6.00

### AUDIO CHOKE

A type of Super audioformer developed for use in filter circuits of power amplifiers and battery eliminators.

CHOKE TYPE, No. 29, Inductance 50 henrys.

Shielded \$6.50 Unshielded \$5.00

*Ask your dealer or write us direct about these and other Pacent Radio essentials*

**PACENT ELECTRIC CO., INC.**  
91 SEVENTH AVENUE NEW YORK CITY

Canadian Licensed Manufacturer :  
White Radio Limited, Hamilton, Ont.

Manufacturing Licensees for Great Britain and Ireland:  
Igranic Electric Co., Ltd., London  
and Bedford, England

# Pacent

## RADIO ESSENTIALS

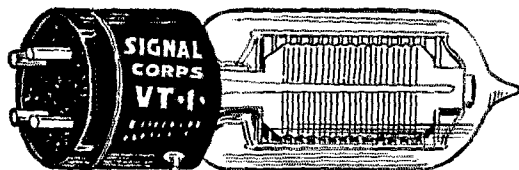

Western Electric Company

## VT. 1

### \$3.45

Commonly Known as the J Tube  
Cost the U.S. Government \$15.00

Fits any Standard Socket. Works  
on 6 Volt Storage Battery

This is the first time in history that these Super Radio Tubes have ever been offered to the radio public. Radio Amateurs everywhere are amazed at this opportunity to be able to buy these tubes at such ridiculously low prices.

The Western Electric VT. 1, manufactured exclusively for U. S. Navy has a much longer life than any other tube known. Characteristic of this tube—when used as a detector—apply 22½ V. to 45 V. to plate and using terminal voltage of 2.75 will show a milliampere reading of 6½ milliampères.

When used as an amplifier with the same terminal voltage mentioned above the 45 to 90 volts plate it will show a milliampere reading of 8½ to 10 milliampères.

VT. 2. TRANSMITTING TUBES \$7.45

### EPPE'S

523 Market St., Philadelphia

# REAL BUYS



## LOOP



Rotatable; embodying certain exclusive principles which give it a greater pick-up than any other loop. Brand new and in original factory carton. List Price, \$12.00. OUR PRICE, \$2.95.

### APCO DIALS

Verter; give hairline adjustment on that short-wave receiver. List \$1.50. OUR PRICE, 45c

### FEDERAL PHONES

2200-ohm in original carton. List, \$7.00. OUR PRICE, \$1.95.

## SIGNAL NAVY RECEIVING TRANSFORMERS

WHAT THE AMATEUR HAS ALWAYS WANTED, brought down to a price he can afford. Covers the wave-length band up to 3500 meters—and not everybody is way down low. Last price, \$12.00. OUR PRICE, \$2.95.

Radio Surplus Corporation

250 WASHINGTON ST. BOSTON, MASS.



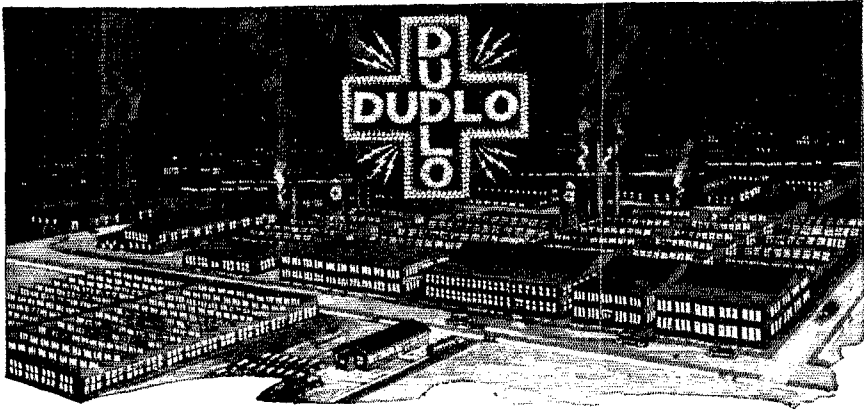

## The Logical Source of Supply For Magnet Wire and Coils

The plain facts are that Dudlo resources, products, and service make Dudlo the logical source of supply

**First: *Volume.*** Volume reflects the ability to supply quantity on short notice. It also reflects organization, facilities, financial strength and popularity of product.

**Second: *Experience.*** The combined experience of Dudlo magnet wire and coil experts affords resources that are not duplicated.

**Third: *Engineering Facilities.*** The Dudlo engineering staff and experimental laboratories offer buyers an expert free service. They function as if they were a part of the buyer's own organization.

**Fourth: *Location.*** Fort Wayne is centrally located on trunk line railroads. With Private side tracks directly connecting, unsurpassed shipping facilities are made possible.

**Fifth: *Branch Offices.*** Branch offices and warehouses at Newark, Chicago, St. Louis, San Francisco and other points, are prepared to efficiently serve those nearer to them than to the Fort Wayne factory.

**Sixth: *Service.*** First, last, and always, the whole Dudlo organization is geared to and revolves around a service that leaves no loop hole for other than complete and uninterrupted satisfaction.

# DUDLO

**DUDLO MANUFACTURING CORPORATION, FORT WAYNE, INDIANA.**

412 Chamber of Commerce Bldg., 160 North La Salle Street 4153 Bingham Ave.  
NEWARK, N. J. CHICAGO, ILL. ST. LOUIS, MO.

274 Brannan St.  
SAN FRANCISCO, CALIFORNIA

SAY YOU SAW IT IN Q S T—IT IDENTIFIES YOU AND HELPS Q S T

# Christmas Specials

Goods Sold on  
**MONEY BACK  
GUARANTEE**

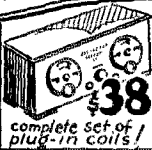

complete set of /  
plug-in coils  
**\$38**

**ABSOLUTELY  
UNSURPASSABLE  
DX RECEPTION**  
WITH THE  
**R-S-100  
SW. RECEIVER**

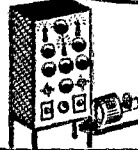

**Amateur &  
Broadcasting  
TRANSMITTER  
INSTALLATIONS  
5-1000 WATTS**

**24 HOUR  
MAIL ORDER  
SERVICE**

**20-40-80  
METERS**



**ARSCO  
PERFECT  
NO-LOSS  
TRANSMITTING  
INDUCTANCE**  
**\$4.45**

FOR  
TUNED PLATE  
& GRID SW  
TRANSMITTER  
UC 1803  
Rebuilt  
genuine  
**CARDWELL**

**RCA-UC 1803**  
000025 MFD.  
10,000 VOLTS  
**75¢**  
**23 PLATE .00022 MFD  
3000 VOLT \$3.35  
VARIABLE  
TRANSMITTING  
CONDENSER**



**AERO  
SW. KITS  
\$9.90**  
**REL  
S-W KITS  
\$3.85**

### FILTER CONDENSERS

Sangamo 2 MFD 1000 volts .....	\$2.25
Sangamo 4 MFD 1000 volts .....	\$3.75
Paradon 1 MFD 1750 volts .....	\$2.52
Acme 2 MFD 2000 volts .....	\$6.25

R. E. L. 40 & 80 meter TRANSMITTING INDUCTANCE .....	\$9.75
Allen Bradley Large Radiostat \$6.25. Radio leak .....	\$4.75
General Radio wavemeter \$19.75 (type 358)	

Full line of equipment for Broadcast Stations

### GRID LEAKS

Ward Leonard 5000 ohm for 50s .....	\$1.85
Ward Leonard 5000 ohm for 250s .....	\$2.80
Crescent Lavite 5000 ohm for 5s .....	\$2.25
General Electric 5000 ohm for 5s .....	\$1.25

Thordarson combined plate & Fil trans-  
former for 5 watters \$6.50. 30 watt  
fil. transf. for 5 watters \$6.25.

Send for our Catalog  
**Amateur Radio Specialty Co.**  
77 Cortlandt Street - New York



## APPROVED PARTS for Eliminators Power Amplifiers

Dongan has perfected transformers and chokes of several types which are used widely with UX, RCA and Raytheon Tubes for both Eliminator and Power Amplifiers.

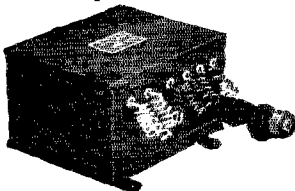

**No. 2568  
ABC Power  
Unit**

Designed for use with Raytheon BH tube. Eliminates all batteries. Built into sturdy good-looking black metal case. List **\$17.50**

### Power Amplifiers for Home Use

Use Dongan No. 2567 transformer half with UX 216 B-tube used in conjunction with List **\$10.00**  
UX power Amplifier tube No. 210.  
Dongan transformers available for all standard types of power Amplifier tubes.

### FANS

Order these and other Dongan parts from your dealer or send to the factory for complete information on constructing eliminator and power amplifier units.

### MANUFACTURERS

For a reliable source of supply on the latest designs Dongan offers quantity production on all approved types. For special requirements our engineering department is at your service.

Special Transformers for Trickle Chargers

**Dongan Electric Manufacturing Co.**  
2859-3001 Franklin St., Detroit, Mich.

TRANSFORMERS of MERIT for FIFTEEN YEARS

**NEW U. X. UNIVERSAL  
Fits All Tubes**

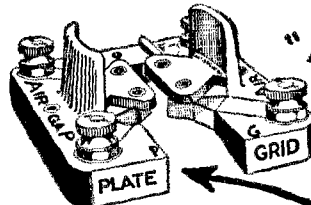

"It gets  
that  
last  
mile"

The **AIRGAP**  
SOCKET

You make your grid and plate leads short and not running parallel to prevent squawks and howls due to undesirable capacity, intercoupling, feedback, etc.

Is there any good reason why you should then use a socket which collects dust, lint, and moisture and bridges the grid and plate terminals with solid matter, making an easy path through and over which intercoupling, etc. takes place.

At Your Dealers or Direct, **80¢ each**

**AIRGAP PRODUCTS CO.**  
13 Campbell St., Newark, N. J.

SEE THAT GAP?

# New Socket-Power Equipment for Stromberg-Carlson Receivers

Built solely to meet the exacting operating requirements of Stromberg-Carlson Receivers—with no detrimental compromises to permit use with other instruments.

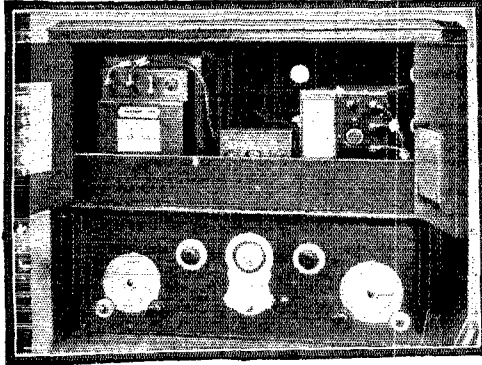

The picture shows the Stromberg-Carlson power equipment neatly installed in a Console model Stromberg-Carlson Receiver.

The tonal excellence, the volume, the range, for which Stromberg-Carlson "Shielded" Receivers are celebrated, is best brought out through the use of only Stromberg-Carlson Accessories. These accessories—with a Stromberg-Carlson Receiver, will enable the earnest amateur to obtain results unattainable in any other way.

The "A" Socket-Power Unit (Gould Uni-power)—manufactured to comply with Stromberg-Carlson requirements, this unit represents the most convenient and reliable source of "A" power available. Several trickle charge rates, controlled by a switch, allow an unflinching current supply under a wide variation of service use. Once the correct setting is determined, no further attention need be given, except for the occasional replenishing of the evaporated water.

The No. 401 "B" Socket-Power Unit—perfected to meet the exact operating requirements without adjustment of the output voltages; there is no danger of unknown voltages unbalancing the neutralization of the radio stages and producing audio distortion through the failure of the "B" voltage to match the negative bias provided by the "C" batteries.

Reserve power, to meet any sudden demands, is made possible by a large capacity condenser across the output leads of the unit. The use of wire-wound resistors imbedded in vitreous enamel prevent any big changes such as occur in units employing the carbon type resistors.

The No. 301 Power-Switching Relay—bridge-wound to insure a uniform pull on its springs irrespective of the number of tubes employed, this relay automatically operates the "A" unit, "B" unit, and an external amplifier (if used)—all from the single switch on the panel of the Receiver.

Although these units were designed primarily for use with Stromberg-Carlsons, certain other Receivers with the same type and number of tubes similarly arranged, may enjoy the advantages of this superior equipment.

STROMBERG-CARLSON TELEPHONE MFG. CO.  
ROCHESTER, N. Y.

# Stromberg-Carlson

Makers of voice transmission and voice reception apparatus for more than 30 years

SAY YOU SAW IT IN Q S T—IT IDENTIFIES YOU AND HELPS Q S T

# THE SUPER SYNC RECTIFIER

## The Synchronous Rectifier That Can Be Filtered

When properly filtered the Super delivers a direct current that is suitable for broadcast transmitters. When using a Super on the transmitter you are assured of a steady voltage, thus assuring a steady wave.

On installing a Super you will immediately notice an increase in DX reports.

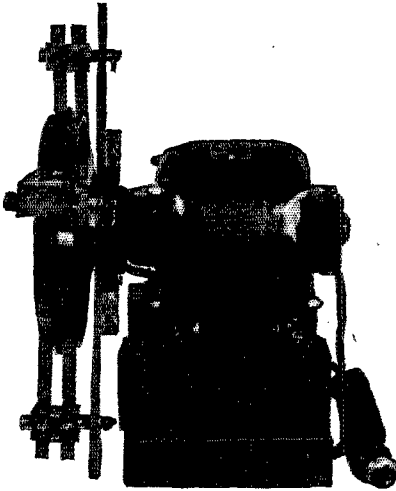

The Commutator on the Super is eight inches in diameter and is turned at a synchronous speed by a 1/4 H. P. Synchronous motor. Contact is made by eight brushes mounted ninety degrees apart in pairs. The brushes run on a smooth surface thus assuring a smooth contact and also preventing the brushes from chattering.

PAT. PENDING  
PRICE \$75.00 F. O. B. ST. LOUIS, MO.

MARLO ELECTRIC CO., 5241 Botanical Ave., St. Louis, Mo.

**FREE!**

*This*  
**84 PAGE RADIO BOOK**

**SAVE 1/3 to 1/2**

**The World's Largest Exclusive Radio Mail Order House**  
will send you—FREE—this wonder catalog of radio bargains containing over 2000 items of everything in RADIO, including all the latest Sets, Kits, and Parts, at rockbottom prices that Save you 1/3 to 1/2

**5-TUBE SETS AS LOW AS \$24.90**  
**LATEST 1927 MODELS**

Table and Console models with built-in loud speakers. Beautiful, genuine mahogany and walnut cabinets. All sets at amazingly low prices.

**SEND FOR BOOK TODAY**  
We cannot begin to tell all about this wonderful Radio Book. Simply send letter or postal, and this bargain radio catalog will come to you absolutely free. Write Today.

**RANDOLPH RADIO CORP.**  
180 N. Union Ave., Dept. 191 Chicago, Ill.

## Build It Yourself

Parts Complete \$14.15  
Including Unit

In one evening and for 1/5 retail cost you can build the finest 3 foot Cone Speaker. Marvellous tone quality; every instrument in an entire symphony orchestra is clear, musical and distinct, even the very lowest. And the cost for ALL the parts—2 sheets Albambra FON-O-TEX, Penn Back Rings, Unit Mountings, special Ambroid Cement and genuine

**Penn Cone Speaker UNIT**  
designed especially for 3 foot Cone Speaker—is but \$14.15.  
PENN Cone Speaker Unit is adjustable to the audio output of any set. Unit alone, \$9.50. If your dealer cannot or will not get the parts for you, we will ship on receipt of price. Pamphlet, "How to Build a 3 foot Cone Speaker for \$14.15," sent for 10c, stamps or coin.

**PENN RADIO SALES CO.**  
104 Fifth Ave. Suite 2015 New York City  
Exclusive Selling Agents for G. R. Penn Mfg. Co., New York

### New Learners Buzzer Practice Set

on base board, consists of key and buzzer, \$1.00; U. S. Signal Corps. Field Telephone sets \$3.00; Cutting & Washington Airplane quenched spark transmitter panels, impact type at \$9.50; Detector, Amplifier, Oscillator, Cabinets, type R. W. 2; maker Mare Island Navy Yard, at \$17.50 each. Just a sample of our bargains. Get our new and latest reduced price list for 2c stamp. We bought \$10,000 worth of United States Government Radio Transmitting and Receiving Sets and Parts. Mail orders sent all over the world.

**WEH'S CURIOSITY SHOP, 20 South 2nd St., Philadelphia, Pa.**

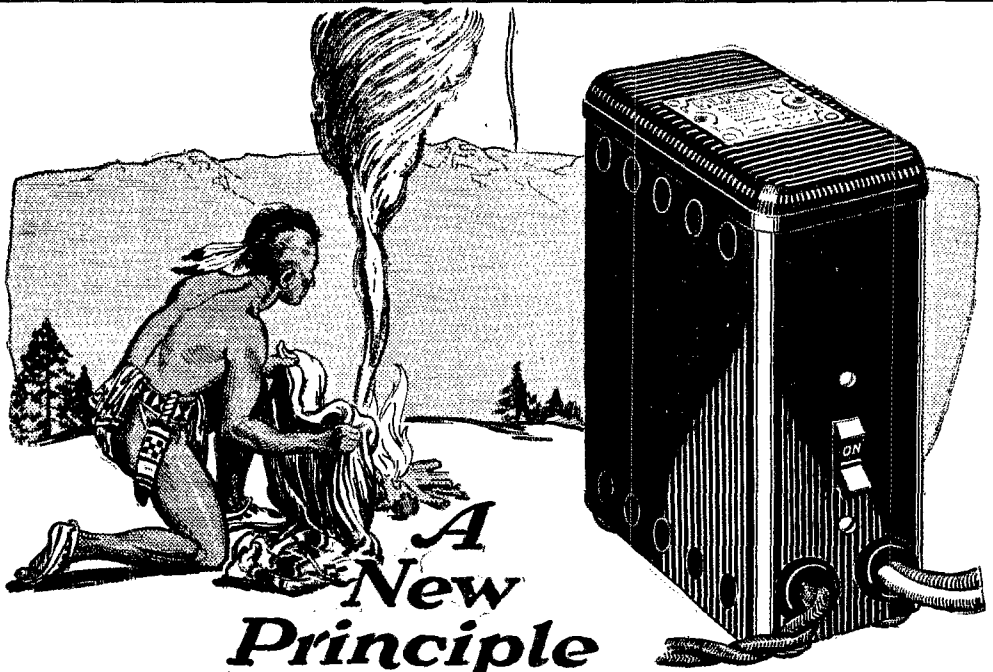

*A  
New  
Principle  
not—just another Charger*

THE ELKON TRICKLE CHARGER is as different from earlier attempts at "A" battery charging as Radio Signalling is from the signal fires of the Indians. All the former expedients necessary to secure current rectification are done away with. Two small discs, of dissimilar substances, in pairs, replace all the water, the acids, the alkalis, tubes and oscillating devices hitherto resorted to. And they not only rectify in a positive manner, but do so without interference, without noise, without heat, and *without attention*.

The Elkon Trickle Charger will operate in *any Position*. Short circuiting cannot harm it. It cannot overcharge for it tapers automatically from 0.7 amps to practically zero. It is full wave.

*Install it . . . set it . . . forget it . . . Your "A" battery charging becomes a perfunctory matter, entirely automatic and dependable, and your time is freed for more important work. You need one.*

Operates from 105-120 v., 50-60 cycles, direct from A. C. **(\$15.00 complete with switch)** 25-40 cycles also available at a slightly higher price

**ELKON WORKS**  
Subsidiary of P. R. Mallory & Co., Inc.

Weehawken, N. J. Inc.

Sole licensees under patents pending to Samuel Ruben

**ELKON TRICKLE CHARGER**

18" INSULATORS—U. S. Navy Type, of red porcelain. Absolutely no leakage. For transmitting antennae and high-tension lines. SPECIAL \$1.00.

# BARGAINS!

For "Dyed-in-the-Wool" Hams

TELEGRAPH KEYS Made to sell for \$1.75. Phosphor Bronze spring and solid silver contacts. SPECIAL ..... 48c

## QUARTZ CRYSTALS

For crystal-controlled transmitter. Each individually tested; accurate within 1 percent. Specifications giving the frequency included. SPECIAL, ..... \$10.00

## SIGNAL CORPS MICROPHONES

Manufactured by Western Electric to be used in government sets. All brand new. SPECIAL, \$6.00

TRANSMITTING GRID LEAKS. Dual resistances for 50-watt tubes in 5000, 10,000, and 20,000 ohm sizes. PRICE \$3.50

RCA UV-712 AUDIO TRANSFORMER, 9-1 ratio. List, \$7.00. OUR PRICE, \$1.60  
RECTIFYING TUBES. Type UX-213. Full-wave rectifier, giving an output of 65 milliamps. \$2.60. Type UX-216B. A high-power half-wave rectifier; unexcelled for transmitting circuits, \$3.00.  
COMMERCIAL TYPE HELIX of No. 2 gauge. Easily converted for the Hartley circuit. \$2.95.

## MAGNAVOX



3-Stage Power Amplifier. AC3V. Can be added in any short wave receiver and brings in that distant C. W. station. Complete with anti-capacity switches. List, \$75.00. OUR PRICE, \$16.50

## BUZZERS

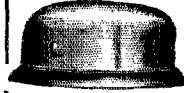

High-frequency buzzers, desirable for testing crystals and practicing code. Gives a sound resembling C. W.  
NEW LOW PRICE 75c

GLOBE HAND MICROPHONE, exceptionally sensitive and unexcelled for "voice." \$18.00

MINIATURE LAMPS for wavemeters, 15c.  
C.R.L. POWER RHEOSTAT for 752 watt tubes. List, \$1.50. SPECIAL, 75c.

RCA UP-1016 750-watt Power Transformer. List, \$38.50. SPECIAL, \$11.50.  
RCA UT-1008 Oscillation Transformer. List, \$11.50. OUR PRICE, \$7.50.  
RCA UC-1803 Paradox Condenser. List, \$5.00 95c.

BLINKER PRACTICE SET Equipped with both a high frequency buzzer and a blinker light, either of which may be switched on for practice. SPECIALLY PRICED \$2.95

## CARDWELL CONDENSERS

Transmitting Condenser, factory rebuilt for 3000 volts, \$2.95.  
King-Cardwell 41-plate condenser, 95c. 11-

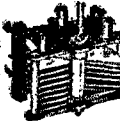

plate condenser, 95c.  
King - Cardwell Dual Condenser, 15 - 15 plates, \$1.95, 11-11 plates, \$1.50.

## KENNEDY 3-CONDENSER GANG

Each .00035 mfd. Plates tapered like the new Cardwell. A BARGAIN AT \$2.50

# RADIO SURPLUS CORPORATION

250 Washington St. Boston, Mass.

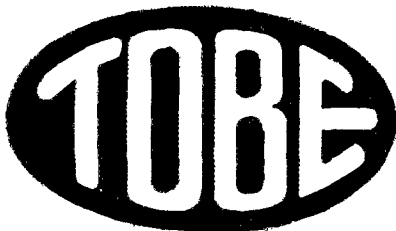

One object only, to make and sell only the best Condensers and other Technical Apparatus.

Tobe Deutschmann Co.

Engineers and Manufacturers of Technical Products  
Cambridge, Massachusetts

## Do You Build Sets?

Responsible builders, competent to construct the new LC-27 HAMMARLUND-ROBERTS and AMERTRAN POWER PACK, are cordially invited to register with ALLEN-ROGERS, the only direct representative of the Committee of 21 manufacturers.

When building the LC-27, it pays to get the complete set of parts from ALLEN-ROGERS, because both you and your customer are protected through the following:

### GUARANTEE

We unreservedly GUARANTEE that anyone can construct the LC-27 Receiver to function properly when built by using a complete set of parts distributed by us. This means that if the set built by you does not work as we claim it should we will make it do so without cost to you, even though we should have to rebuild the entire set.

Write for discounts on complete sets of parts for

LC-27  
HAMMARLUND-ROBERTS  
AMERTRAN POWER PACK

Direct Representative of the Committee of 21 Manufacturers

**Allen-Rogers**  
Incorporated

"Kit Headquarters"  
118 East 28th St., New York, N.Y.

# ADD to YOUR "B" Eliminator for Better tone through a *Mershon* ELECTRIC 30 MFD-Duotype CONDENSER

Mershon Electric Condenser 15 mfd's capacity each half. 30 mfd's total capacity. Type D-15-30. Maximum rating 300 volts D. C. If punctured can be reformed and need not be thrown away.

## Make Your Old B Eliminator a Super B Supply



Your present B Eliminator can be vastly improved by connecting a Mershon Condenser across the output voltage terminals! You will then get a wonderful tone quality from your radio receiver as the very large capacity of the Mershon (30 mfd) will act as a reservoir to STORE energy to be on tap to instantaneously supply the heavy drains of plate current required by loud or long sustained notes. No doubt, you have noticed that although your B eliminator gives no AC hum you do not get that perfect reproduction of tones that was possible using new B batteries.

To simply filter out the light socket current hum is but part of the job. Eliminators must have STORAGE capacity to prevent "chopping off" the loud or sustained notes. Using a Mershon Condenser for this storage capacity gives the quality of expensive storage batteries and does the work electrically rather than chemically, this in turn means there is no deterioration, adding of water, no elements to occasionally clean, no parts to be replaced. In other words a more SERVICEABLE device is at hand, as well as one providing amazing tone quality.

A famous Mershon added to your eliminator or used as the principal capacity of any B eliminator enables your set to reproduce notes from bass to treble with astounding accuracy.

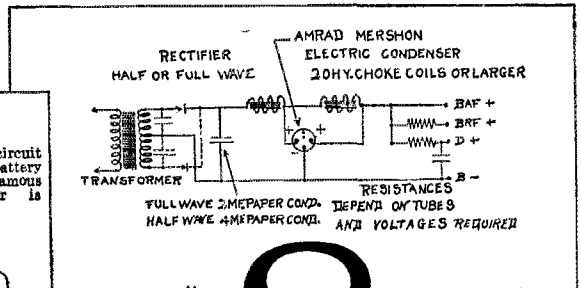
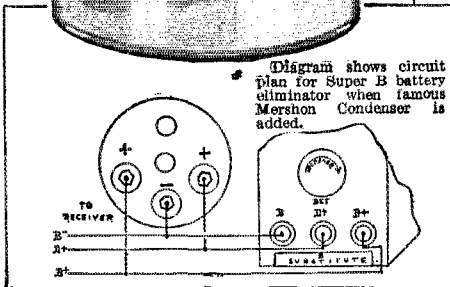

AMRAD CORPORATION  
Medford Hillside, Mass.

# AMRAD

Battery Type and Light Socket Operated Neutrodyne

SAY YOU SAW IT IN Q S T—IT IDENTIFIES YOU AND HELPS Q S T

Write  
Dept. 4L  
If Your  
Dealer  
Cannot  
Supply

Accurate Primary Coupling at Every Condenser Setting with the New  
**HAMMARLUND "AUTO-COUPLE"**

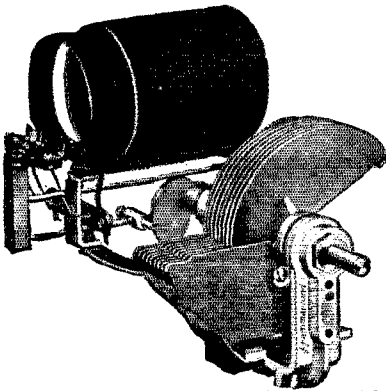

AN assembly of Space-Wound Coil, "Midline" Condenser and Aluminum Shield giving automatic graduated primary coupling at every condenser setting and insuring maximum transfer of energy at each wavelength, with effective control of oscillations.

Coils, condensers and shields are sold separately and are easily assembled. The shield is designed to inclose the complete assembly including a tube and its socket.

Most good radio stores sell Hammarlund-Precision Products—if yours doesn't, write us direct.

HAMMARLUND MANUFACTURING CO.  
 424-438 W. 33rd Street, New York

For Better Radio  
**Hammarlund**  
 PRECISION  
 PRODUCTS

Among the season's new kits for which Hammarlund Precision Products are officially specified are: Cockaday's "LC-27"; Sargent's "Infra-dyne"; Lacault's "LR4"; St. James Super; the New Harkness; "Henry-Lyford"; Morrison's "Varion"; Victoreen Superheterodyne; Loftin & White; Pacent "Ultimax"; Browning-Drake; Popular Science Monthly "Powerful"; Hammarlund-Roberts "Hi-Q".



*Jaradon*

**"UNIVERSAL"  
 Capacitor Block**

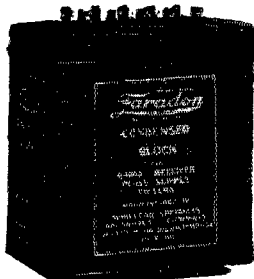

Designed especially for operation in connection with generally used Battery Eliminator Circuits. Total capacitance 14.2 Mfds., connected to fixed terminals in convenient units permitting ready wiring in desired capacity combinations.

High factor of safety to withstand possible high voltage surges.

Also By-Pass and Filter Units in individual containers.

If your dealer has not the Capacitor Block on hand advise us.

**WIRELESS SPECIALTY APPARATUS COMPANY**

Established 1907

Jamaica Plain Boston, Mass., U. S. A.

**THE NEW WESTERLAND  
 SUPER-VERNIER  
 TUNING DIAL**

- Gets Better Results Because:**
1. Sharper Tuning (150-to-1 gear ratio).
  2. Quicker Tuning (instant jump from station to station).
  3. Easier Tuning (stations logged on face of dial—no charts or log-books needed).
  4. Simple operation (one-knob control).
  5. Absolute elimination of backlash (new worm-gear movement guarantees this).
  6. Easy to attach (no holes to drill in panel).

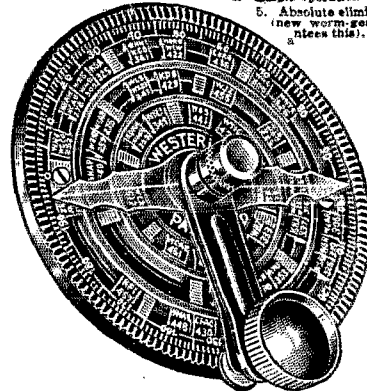

With the WESTERLAND Super-Vernier Dial you can hit the PEAK of the wave every time. This means better reception, longer distance, freedom from interference—in short, maximum results from your set.

Price \$2.50  
 POSTPAID

**WESTERLAND  
 CORP.**  
 Dobbs Ferry  
 NEW YORK

**UNBASED OR BRASS BASED  
 GUARANTEED RADIO TUBES**  
 by return mail!



Direct from factory saving wholesale and retail dealers profits. Quarter amp. 201-A type standard base. Suitable for short wave transmitters and receivers. Trelcot Sales 1021 Moseley Owensboro, Ky. prepaid

**69c**



REL

REL

# QUALITY REL PRODUCTS

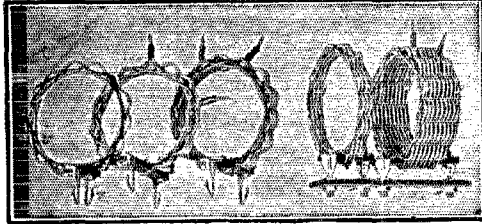

**REL Low Wave Plug-in Coils**—The Pioneer in its field. Unit consists of five coils, wave length range 10-110 meters, plugs and mounting. Adaptable to all modern circuits. Inexpensively priced at \$4.50.

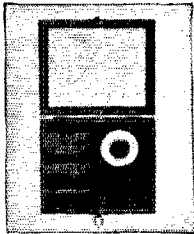

**REL Wave Meter**—Suitable for general usage. Wave length range 17-550 meters, with Neon tube indicator. Type "A" complete is \$22.00.

**THE** Holiday Season reminds us that another year has slipped by, and REL still occupies the topmost rung wherever Short Wave apparatus is found.

Those articles featured on this page are but a few of the very many remarkable values to be obtained thru REL. Our products undergo the severest tests for durability and class of performance. Every piece of apparatus that we turn out is, indeed, the Finished Product.

REL will continue to supply those who know and demand the highest Radio quality.

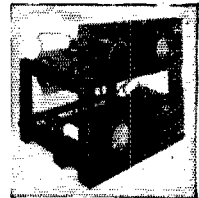

**50 Watt Coupled Hartley Transmitting Kit, TR-50**—A hard one to beat for appearance, performance and quality. A real buy at \$63.00.



**Short Wave Receiving Kit**—A triumph in its field! Each item has been selected for its quality of performance. Wave length range 10-206 meters.—\$36.00

SEND today for the new REL Short Wave Booklet containing data and hookups such as, Tuned Grid, Master Oscillator, Crystal Control and a wealth of information invaluable to every devotee of Short Wave Radio. Get it!—25c.

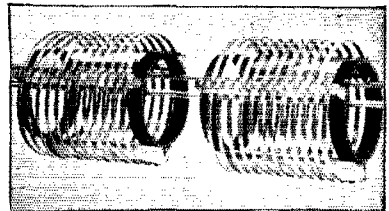

**REL Transmitting Inductances**—Flat-wound on glass. The inductance that you must eventually use.  
Type L—(40, 80, 150 meters wave-lengths)  
Type S—(20 meters and less)  
Single Unit, either type, with three clips \$5.50  
Double Unit, either type, with six clips \$11.00

REL OWNS AND OPERATES EXPERIMENTAL STATION 2XV ON 15.1 METERS, 19867 KILOCYCLES, CRYSTAL CONTROLLED.

## Radio Engineering Laboratories

27 Thames Street, N. Y., N. Y.

REL

REL

# ELECTRAD

Want Clearer  
Purer  
Reception?  
Do This:

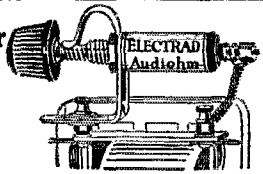

Place an Electrad Certified Audiohm across the secondary of your transformer. Get the low notes and high notes full, clear and undistorted. Whatever set you have, the Audiohm will make it better. Can be attached instantly. No soldering. Comes all equipped. Buy one today. Good radio stores have them. Price U. S. \$1.50. Canada \$2.10.

**A Better Rheostat —  
Six Reasons Why**

1. Resistance guaranteed within 5%.
2. Milled shaft with squared hole in contact arm insures rigidity—no wobble of shaft.
3. Extra long metallic bearings.
4. Highest grade Bakelite insulation, maximum radiation and mechanical strength.
5. Single hole or three-hole mounting. For three-hole mounting, base is tapped, eliminating need of nuts behind panel.
6. Phosphor bronze spring contact arm insures contact.

In every respect a better rheostat—6, 10, 20 and 30.



## A Better Rheostat—

**Six  
Reasons  
Why**

1. Resistance guaranteed within 5%.
2. Milled shaft with squared hole in contact arm insures rigidity—no wobble of shaft.
3. Extra long metallic bearings.
4. Highest grade Bakelite insulation, maximum radiation and mechanical strength.
5. Single hole or three-hole mounting. For three-hole mounting, base is tapped, eliminating need of nuts behind panel.
6. Phosphor bronze spring contact arm insures contact.

In every respect a better rheostat—6, 10, 20 and 30 ohms. Price \$1.25; in Canada \$1.75. Potentiometers—200 and 400 ohms. List \$1.50—in Canada \$2.00.

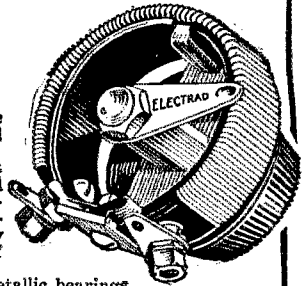

For perfect control of tone and volume use the Electrad 500,000-ohm compensator. For free hookup write 428 Broadway, New York City.



# ELECTRAD

## Hoyt CELLCHEK

Your friend who owns a Radio Storage-Battery would be tickled to death if you made him an Xmas present of one of these new and more accurate instruments for testing Radio and automotive storage batteries. The electrical meter indicates instantly whether the battery needs recharging, is low or in good condition, and it operates without the withdrawal of a drop of acid, keeps hands clean and protects rugs and furniture.

THE HOYT CELLCHEK  
Price—\$2.50

**BURTON-ROGERS CO.**  
BOSTON, MASS.  
(Sales Dept. for Hoyt Electrical Instrument Co.)

## Nonoise Variable Grid Leak

Operates on a new principle. Retains adjustment. Noiseless. Range 1/2 to 7 megohms. Get Manufacturers who do not skimp on equipment use it in their sets. If your dealer does not stock them send us 85c and we will send you one.

**RADIO FOUNDATION, Inc.**  
25 West Broadway, New York, N. Y.

## V.T. 14 Transmitting Tubes

Rated at 5 Watts

(MFD BY GENERAL ELECTRIC CO.)  
NEW, IN ORIGINAL CARTONS

Filament Voltage 7 1/2 Volts.  
Filament Current 1 3/4 Amps.  
Safe Plate Voltage 550 Volts.  
Plate Current 40 Milli-amps.

Also Used as Power Amplifying Tube  
STANDARD BASE

**PRICE ONLY \$1.50** E.A.

**American Sales Co.,**  
21 Warren St., N. Y. C.

---

---

# “What do you mean — PIONEERS?”

You readers of QST are the real Pioneers of Radio. You started back in the days when “Amateur” really meant amateur.

It was back in those same days that Acme started as a Pioneer Radio manufacturer.

You remember that Acme was first to put on the market:

1. Audio Frequency Transformer
2. B-Eliminator using Raytheon Tube
3. C-Eliminator.
4. Free-Edge Cone Loudspeaker
5. High Spark Frequency Transformers
6. C.W. Transformers and Choke Coils
7. Reflex Circuits
8. Pot-Rheo
9. Silver Plated Condensers
10. Impedance Leak
11. Filter Unit

Today, Acme is a year ahead in the two most important ends of radio reception — quality and elimination. For quality, Acme offers the new Amplifier in three stages, first, resistance coupling, second, transformer coupling, and last, resistance coupling with impedance leak; as well as three styles of loud speakers that give, “reproduction without distortion.”

See Acme's contributions to quality and elimination at any good dealer's, and send 10 cents for new Acme booklet, “Power Supply for Radio Sets.”

**ACME APPARATUS COMPANY**  
Dept. E-20, Cambridge, Mass.

## **ACME** == *for amplification*

# The Ideal Christmas Gift

Two of America's best radio publications at a reduced price

## Radio Broadcast-QST Combination Offer

At a saving of \$1.50

Radio Broadcast	\$4.00	} A year's subscription to
QST . . . . .	\$2.50	
	<u>\$6.50</u>	
		<b>Both for</b>
		<b>\$5.00</b>
		(Either new subscriptions or renewals—please state which.)

Send your remittance to

**QST, 1711 Park Street, Hartford, Conn.**

P. S. And at the same time, give yourself a Christmas present. Renew or extend your own subscription at this special price.

### ACME CELATSITE BATTERY CABLE

-- a silk-covered cable of vari-colored Flexible Celatsite wires, for connecting batteries to set. Prevents "blowing" of tubes; gives your set an orderly appearance.



#### The Original Celatsite

-- a tinned, copper bus bar wire with non-inflammable "spaghetti" covering, for hook-ups. 5 colors; 30-inch lengths.

We also offer the highest grade of "spaghetti" tubing for Nos. 10 to 18 wires. 5 colors; 30-inch lengths.

Send for Complete Acme Wire Products Folder

ACME WIRE CO., DEPT. S, NEW HAVEN, CONN.

### ACME WIRE MAKES BETTER RADIO

#### FAMOUS "BH" TRANSFORMERS BH VIVAPHONIC

For quality of amplification, use the only Low-Loss, Shield Structure Audio transformer made. (Patented) Write for Catalogue illustrating Audio and Transmitting Transformers.

BENJAMIN HUGHES ELECTRIC CO.  
298 Leguachetiere St., W. Montreal, Canada  
Transformer Builders Since 1910

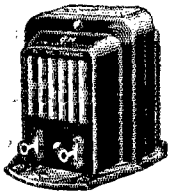

## ANNOUNCEMENT!

WE NOW HANDLE A COMPLETE LINE OF SIGNAL WIRELESS TELEGRAPH KEYS. ORDER FROM US FOR QUICK SERVICE.

Write for our SPECIAL CATALOG of "ham" material.

### Radio Surplus Corporation

250 Washington St., Boston, Mass.

## RECEIVERS TRANSMITTERS - EQUIPMENT

Ensall Radio Laboratory Equipment is built to a Quality Standard. All Apparatus is fully Guaranteed. The Highest Quality Parts are employed in our Wavemeters, Receivers, Transmitters, Master Oscillators, etc. Special Equipment built to order. Quotations furnished upon receipt of data on the Equipment you desire. We build any Equipment you desire from your parts or we can furnish same. All Equipment fully Tested and sold with a Dual Guarantee.

### Ensall Radio Laboratory

1208 Grandview Ave., Warren, Ohio  
"Pioneer Builders of Short Wave Apparatus"

# Cardwell

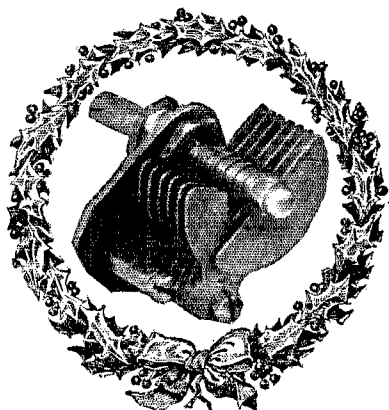

The Cardwell  
**"BALANCET"**

Ask for the 36-page Handbook and Catalog  
Also the Short Wave Receiver Book

Merry Christmas!  
To These Amateurs



Who all use Cardwell Condensers

THE CARDWELL "Balancet", a new addition to our line, has many applications in amateur construction. Its compactness, extreme low cost construction, and wide spacing make it electrically more efficient than even the regular "Cardwell Condensers", and for an antenna series condenser or regeneration control, it is excellent.

It is particularly adaptable for a short wave tuning condenser. A variety of sizes in this one hole mount style assure that one is available for every purpose. A quarter inch shaft makes it useful with any dial.

## "BALANCET"

Type	Capacity	Price
605-A	.000016	\$ 1.25
607-A	.000025	1.25
609-A	.000033	1.25
611-A	.000041	1.50
613-A	.000050	1.50

## Receiving

"Type C"	"Type E"	Capacity Mmfd	Price
167-C	191-E	75	\$ 3.75
168-C	167-E	150	4.00
170-C	168-E	250	4.25
171-C	169-E	350	4.75
172-C	192-E	500	5.00

## Transmitting

VARIABLE			
Capacity Mmfd	Type No.	Breakdown Voltage	Price
250	164-B	3000	\$ 7.00
440	147-B	3000	10.00
217*	157-B	3000	12.00
156	183-B	5250	15.00
297	166-B	7600	70.00
FIXED			
250	501	3000	\$ 4.50
440	502	3000	7.00
966	503	3000	10.00
250	504	5250	15.00

\*Has two insulated stators—capacity of each.

The Allen D. Cardwell  
Manufacturing Corp.

81 PROSPECT STREET  
BROOKLYN, N. Y.

"Standard of Comparison"

# Condensers

# You can take it easy with the Improved "Gold" Bug

Now you can send as much as you want without tiring. The new adjustable grip feature of the Bunnell "Gold" Bug permits shifting of the hand to any convenient position. It is just the key for the "gang."

Fast, accurate sending is possible with this simple, easily adjusted key. Furnished with extra heavy contacts for ship work when specified. Guaranteed and sold on a money-back basis by an organization with over 40 years' experience in manufacturing transmitting apparatus.

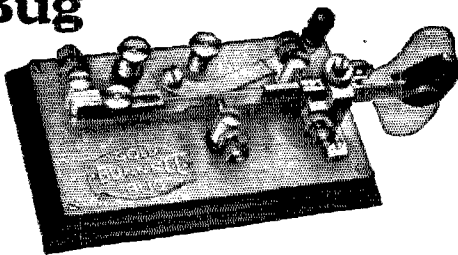

**Only \$12.50**

with cord and plug. With extra heavy contacts, \$13.50. Carrying Case, \$3.50 extra.



## J. H. BUNNELL & COMPANY, Inc.

HEADQUARTERS FOR TRANSMITTING APPARATUS SINCE 1878

32 PARK PLACE, NEW YORK

Phone: Whitehall 5970

**SET BUILDERS**  
IF YOU ARE INTERESTED IN SAVING MONEY  
SEND FOR THE

### Builders Kit and Price Guide

WHEN WE SAY "SAVE MONEY" WE MEAN—  
WELL—FOR EXAMPLE:

COCKADAY'S NEW LC-27 FOR ONLY	\$69.75
WITH CORBETT-CABINETT	34.52
IMPROVED BROWNING-DRAKE	54.77
SARGENT'S INFRA DYNE	59.50
IMPROVED RAYTHEON B SUPPLY	36.72
DE JUR RESISTANCE COUPLED	
AMPLIFIER 3-STAGE	7.54
OUTPUT FILTER CIRCUIT	7.68

Exact Parts As Used And May Be Purchased At Ham Prices—Get The Guide Before Buying Elsewhere. Many Other Items Covering Full Line Of Receiving And Transmitting Equipment, Blue-Prints Of Kits Giving Full Constructional Details for 50c And The Name and Address of an Interested Radio Friend.

**HAMMARLUND MIDLINE DUAL CONDENSER** (LIST \$7.50) \$5.97; **SINGLE CONDENSER** (LIST \$4.65) \$3.95. **PRECISION DUO OCTOFORM COIL SET** (LIST \$10.50) \$8.85. **AERO TUNED R.F. KIT** (LIST \$12.00) \$9.75; **LOW WAVE TUNER KIT** (\$12.50) \$9.87. **JEWEL METER NO. 135 FOR PANEL MOUNTING O-10 OR O-100** (LIST \$7.50) \$5.97. SENT PREPAID; 25% DEPOSIT ON ALL C. O. D. ORDERS.

M. B. S. SALES CO. 27 SCHOOL ST., DEPT. F., BOSTON, MASS.

Laboratory Product



### CRESCENT LAVITE RESISTANCES

For Distortionless Amplification

Dual resistance for DeForest "H" tube \$3.50. (Consists of two units mounted on bakelite and connected in parallel.)

Please specify if your "H" tube requires 60,000 ohms or 20,000 ohms

All amateur apparatus in stock. Let us drill and engrave your panels

CRESCENT RADIO SUPPLY CO., 6 Liberty St., Jamaica, N. Y.

## Make Money Sell Radios Save Money

We will pay you \$25 to \$60 cash for every order you take as our Neighborhood Agent. Just demonstrate the glorious tone, amazing distance, and volume of Premier Radios in your own home or place of business. Quote our low FACTORY price, and orders come EASY!

Special Price on Demonstrator

\$2450

5 TUBE Tuned Radio Frequency Hook-up (Licensed by U. S. Navy Dept. Walnut finish cabinet. You sell for \$50.00.)



FREE TRIAL

Net Price to Agents After Trade-in

5-Tube CON-4520 SOLE in elegant 2 toned Walnut finish cabinet.

You Sell for \$117



Premier Radio Receivers sell themselves, because of our unusual FREE TRIAL OFFER! You'll find there is nothing on the market equal to Premier quality at Premier's low price because we manufacture every part.

### Trade-in Old Sets

Yes, Sir! Our Agents can take the old "Squealers" in trade, and that alone opens up hundreds of opportunities to take orders and make profits, in every neighborhood.

Write for Sensational Offer to Neighborhood Agents  
**PREMIER ELECTRIC CO.**  
Dept. 195 Grace Street at Ravenswood Ave., CHICAGO

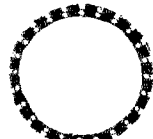

### "JACOBS' ANTENNA SPREADER"

DIAMETER 7 IN. Pat. Sept. 8, 1925; Sept. 7, 1926 Made of metal for erecting either a 4, 6, or 8 wire Cage Antenna. J. S. Arnold, SAAI writes "The Spreaders are the stuff I have them in a 8 wire Cage and it's a beauty, and works excellently." Price \$5.00 per dozen; \$2.75 for a half dozen. Circular upon request.

CHARLES F. JACOBS (2EM)  
279 Park Place Brooklyn, N. Y.



## POWER RHEOSTATS

Model PR-535



For controlling filaments of U. V. 202, 216, U. X. 210 and 216 B. Tubes. Each Rheostat has two windings giving four different resistance values from 1.5 to 6 ohms, and has a large rated current carrying capacity up to 2.5 amps.

LIST PRICE \$2.75 Ea. **SPECIAL PRICE, 65c Ea.**  
**AMERICAN SALES CO.** 21 WARREN STREET, N. Y. C.



# Instruments

## are NECESSARY—

—to meet the individual need of every set for filament adjustment. The construction of the tubes in your set is such that when the filament voltage is right—the filament current is right, and when the current is right the filament is heated to just the proper temperature to work consistently at its maximum without injury. Utmost satisfaction in radio operation cannot be secured by guess-work. Regulated filament voltage pays good dividends in improved reception, saving in batteries and tubes and greater enjoyment.

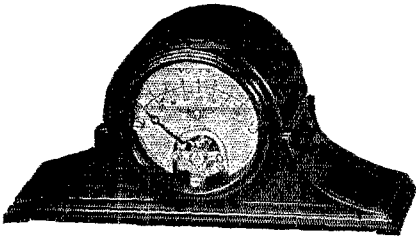

Pattern No. 135-C portable Voltmeter "DeLuxe"

Pattern No. 135-C has the feature of being the most beautiful portable voltmeter obtainable as well as being a highly accurate and durable double scale instrument for testing batteries and circuits, and checking filament voltage. It is a quality product and will fit in with the most luxurious home appointments. Its double scale, (0-7.5, 150 Volts) makes it the ideal instrument for home testing. Furnished with flexible phone tipped leads.

Pattern No. 135-A Jewell tip jack voltmeter is the last word in an adjustable instrument for testing filament voltage by plugging into the jacks mounted in the panels of Victor, Brunswick, Radiola and many other sets. It is obtainable in 0-5, 0-7 or 0-50 volt scales. Like all Jewell instruments it has a zero adjuster and silvered parts.

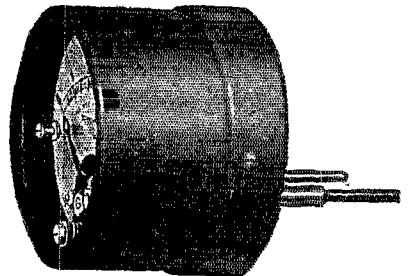

Pattern No. 135-A tip Jack Voltmeter

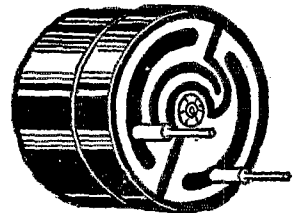

Back view of pattern No. 135-A voltmeter showing the rotating back plate with adjustable prongs. This patented arrangement permits instant adjustment to either horizontal or verticle arrangement of the jacks on the set panel with the instrument scale always in the truly horizontal position. No other similar instrument has this important adjustment advantage.

Send for our circulars Form Nos. 1015 and 1016  
which feature the above instruments

## Jewell Electrical Instrument Co.

1650 Walnut St. Chicago

"26 Years Making Good Instruments"

# Ward Leonard VITROHM RESISTOR



Grid leak for use with 250 Watt Transmitting Tube.

Resistance of 5000 ohms, center tapped. Wire wound on 8 1/2 inch tube, enclosed in vitreous (glass-like) enamel.

Practically indestructible; permanently accurate; non-inductive; zero temperature co-efficient.

By mail postpaid \$2.90 including mounting brackets.

Can also furnish a 20,000 ohm grid leak unit for the new De Forest type "H" transmitting tube. \$6.15 postpaid.

50,000 ohm grid leak unit for the new De Forest type "P" transmitting tube. \$8.60 postpaid.

Ward Leonard Electric Company



7131-6

Mount Vernon, N. Y.

SEE THAT SCREW

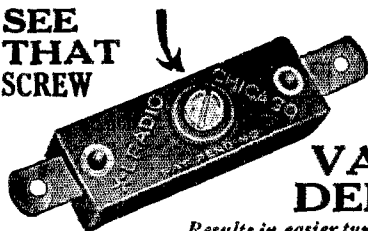

A screw driver - adjusts an - XL in crowded places.

## X-L VARIO DENSER

Results in easier tuning, more distance, volume and clarity—greater stability. Indorsed by leading radio authorities.

Model "N"  
A slight turn obtains correct tube oscillation on all tuned radio frequency circuits. Neutrodyne, Roberts two tube, Browning-Drake, McMurdo Silver's Knockout, etc. Capacity range 1.8 to 26 micro-microfarads. Price **\$1.00**

Model "G"  
with grid clips obtains the proper grid capacity on Cockaday circuits, filter and intermediate frequency tuning in heterodyne and positive grid bias in all sets. Capacity range Model G-1 .00002 to .0001 mfd. Model G-5 .0001 to .0005 mfd. Model G-10 .0003 to .001 M. f. d. Price \$1.50

X-L Push Post  
Push it down with your thumb, insert wire, remove pressure and wire is firmly held. Releases instantly. Price 15c. Also furnished mounted on strips. Also furnished screw on marked insulating strip.



X-L RADIO LABORATORIES  
2428 N. Lincoln Avenue Chicago, Ill.

## Bradleystat

PERFECT FILAMENT CONTROL

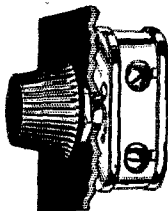

Provides complete noiseless filament control for all radio tubes without change of connections. Metal parts are nickel plated. One hole mounting. Self contained switch opens battery circuit when desired.

Allen-Bradley Co.

Electric Controlling Apparatus  
277 Greenfield Avenue  
Milwaukee, Wis.

Selected by engineers for use in leading circuits because they're

metallized!



DURHAM RESISTORS



Never Before At This Sacrifice Price  
**HIGH VOLTAGE  
KENOTRON RECTIFYING TUBES**

(RCA) MODEL U. V. 217 (RCA)

A. C. Plate Voltage 1500 volts. Filament Voltage 10 volts.

Used with U. P. 1016 Power Transformer or similar Transformer.

These Genuine R.C.A. U. V. 217 Tubes are very efficient Rectifiers and they will pass plenty of current and voltage for 50 watters and H Tubes and also can be used for 250 watters. Every tube is brand new and packed in original carton.

List Price \$26.50 ea.

**EXTRA SPECIAL, \$12.50 EA.**

American Sales Company

21 Warren Street, New York City



# A Master Product!

Designed for Reliable  
Long Distance Communication

on

1 Meter to 200 Meters

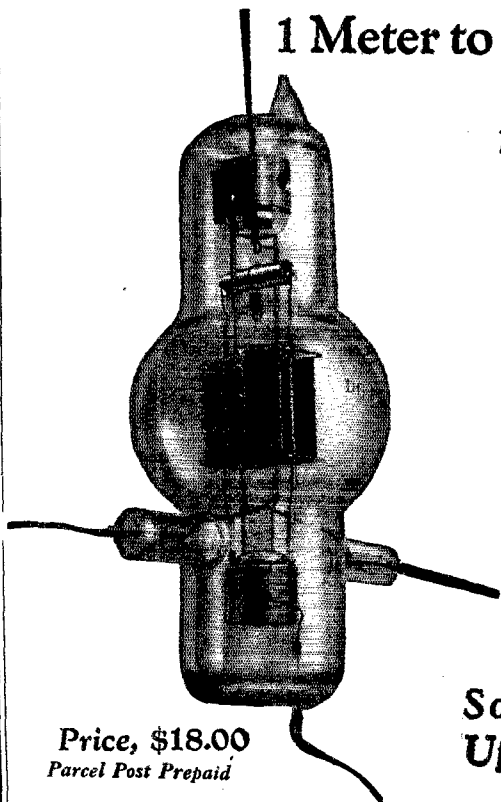

Price, \$18.00  
Parcel Post Prepaid

INPUT RATING 150 WATTS

Plate Voltages 500-3000  
Plate Currents 40-50 MA.  
Fil. Voltage 10  
Fil. Current 2.35A

Thermonic HR Rectifiers

Will operate 4 H tubes

Fil. Voltage 10  
Fil. Amperes 2.35  
Plate Voltage A.C. 2000  
Plate Mill Amps. 250 Max  
Voltage Drop 400 at 250 MA  
PRICE \$16.00

*Sold and Shipped Direct  
Upon Receipt of Money Order*

# DE FOREST

# TYPE-H

# TRANSMITTING TUBE

139 Franklin St.

DE FOREST RADIO CO.

Jersey City, N. J.

SAY YOU SAW IT IN Q & T—IT IDENTIFIES YOU AND HELPS Q & T

# SERVICE—to the Amateur, Broadcaster, Dealer

Experience has taught thousands all over the globe that the E. F. JOHNSON COMPANY is a really good source of supply for both transmitting and receiving apparatus. Years of experience, adequate technical qualifications, best of material and service have made it so. We solicit inquiries from bona-fide dealers, educational and other institutions, broadcasters, etc., as well as the Amateur.

We're glad to announce DeForest Transmitting Tubes

Type P, 250 watts Output	\$110.00	Type PR Rectifier	\$90.00
The famous H Tube	18.00	Type HR Rectifier	16.00
Type D, 30 watts input	9.00	Type DR Rectifier	8.50

Note that rectifier tubes are now available for 250 watt tubes in the type PR rated at 4000 volts, 750 M. A. maximum.

Be sure to get our free catalog, the HAMALOG, listing a very complete line of transmitting and receiving supplies

**E. F. JOHNSON COMPANY                      9ALD                      Waseca, Minn.**

THE TUBE WITH THE SENSIBLE GUARANTEE

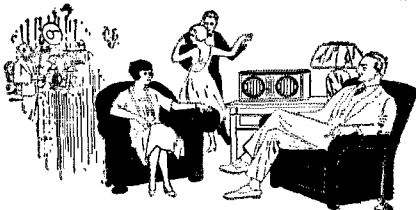

## A Broadcasting Studio In Your Home

Supertron tubes are internally re-inforced by a rigid construction that combines all the elements into one unit "Isolantified." Reception coming through Supertrons will make you feel like the Broadcasting Station is right in your home.—Try them.

**YOUR MONEY WILL BE REFUNDED IF THEY ARE NOT BETTER**

ALL TYPES AT PUBLIC DEMAND PRICES

SX 201 A	..... \$2.00	SX 171 Power	..... 5.00
SX 199	..... 2.25	SX 200 Detector	..... 5.00
SV 199 small	..... 2.25	SX HIMu	..... 3.00
SV 199 large	..... 2.25	SUPERTHEON Half	4.00
SX 112 Power	..... 5.00	SUPERTHEON Full	5.00
SX 120 Power	..... 2.50	In Canada slightly higher.	

**SUPERTRON MFG. CO., Inc.**, Hoboken, New Jersey  
Chicago Office: 39 North Dearborn St.  
Export Dept.: 320 Broadway, N. Y. C.

**SUPERTRON**

A SERIAL NUMBER GUARANTEE  
The Foremost Independent Tube in America

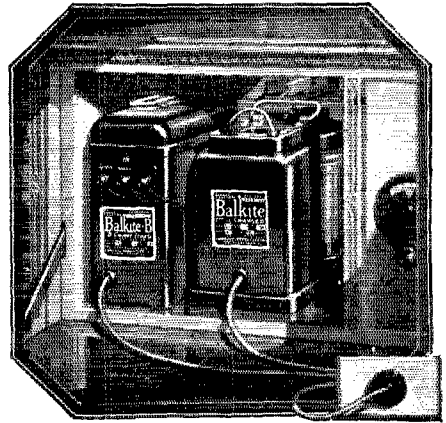

Operate your radio set from the light socket with Balkite "B" and a Balkite Charger

Ask your radio dealer

**FANSTEEL PRODUCTS CO., INC.**  
North Chicago, Ill.

THE AMERICAN RADIO RELAY LEAGUE  
HEADQUARTERS HARTFORD CONN. U. S. A.

**RADIOGRAM**

TO: \_\_\_\_\_

THIS MESSAGE WAS RECEIVED AT \_\_\_\_\_

RECEIVED AT \_\_\_\_\_

DATE \_\_\_\_\_ TIME \_\_\_\_\_

## A New A. R. R. L. Message Blank

The new standard message blank is ready. Get your winter supply now.

1 pad (100 sheets) 35c postpaid  
3 pads (300 sheets) \$1.00 postpaid

**A. R. R. L., 1711 Park Street, Hartford, Conn.**



← IT HOWLS

Now it doesn't!

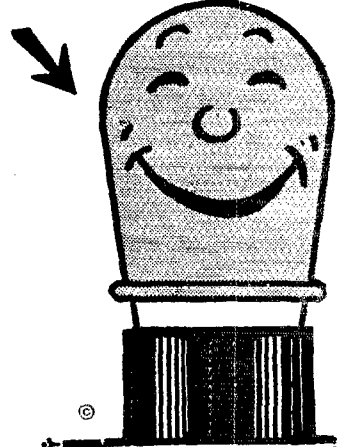

# MCDONALD HOWL ARRESTER

(TRADE MARK)

*"It Stops that Howl!"*

Slip one of these live rubber jackets over each trouble-making tube . . . and the Howl stops.

Remember the name! You can get it for every size tube. It sells for 75c each. Just ask your dealer, or write.

*Sole Selling Agents for the U. S. A.*

**SPARTAN ELECTRIC CORPORATION**  
350 West 34th Street, New York City

*Manufactured in the U. S. A., by the*  
**SCIENTIFIC PRODUCTS CANADA, LTD.**

*"It Stops that Howl!"*

## Bradleyleak

THE PERFECT GRID LEAK!



Provides a noiseless range of grid leak resistance from  $\frac{1}{4}$  to 10 megohms. Assures most effective grid leak resistance value for all tubes. Small grid condenser (0.00025) is separate. Metal parts nickel plated. One hole mounting.

**Allen-Bradley Co.**

Electric Controlling Apparatus  
277 Greenfield Ave., Milwaukee, Wis



## The G-R CIRCLE CUTTER

Cuts Holes in Radio Panels  $\frac{3}{8}$  to 3 in.

Price 65 Cents

A simple adjustable tool to cut mounting holes in Radio Panels. Fits into an ordinary carpenter's brace. Sent post paid on receipt of check or money order. Dealers write for discount.

**Garrison - Rumely** 3020 SHERIDAN RD.  
CHICAGO, ILL.

## Radiohms and Potentiometers

Centralab non-inductive, variable resistances are controls of graphite type that insure smooth, noiseless tuning and permanent service. A single turn of the knob gives stepless variation of resistance from zero to maximum. Centralab Radiohms have two terminals, and can be furnished with maximum resistances of 2,000, 25,000, 50,000, 100,000 or 200,000 ohms. Centralab Potentiometers have three terminals, and are furnished in resistances of 400, 2,000 and 500,000 ohms. There is a type adapted to every radio circuit for control of oscillation, or volume.

Write for literature describing these and other Centralab super-quality controls.

**Central Radio Laboratories**  
20 Keefe Ave., Milwaukee, Wis.

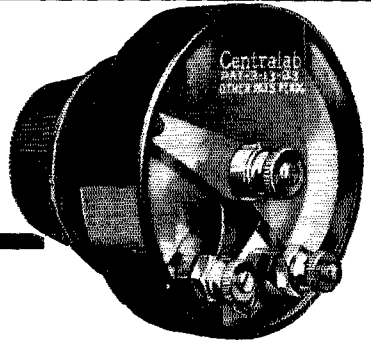

# Centralab

### To Our Readers Who Are Not A. R. R. L. Members

Wouldn't you like to become a member of the American Radio Relay League? We need you in this big organization of radio amateurs, the only amateur association that does things. From your reading of *QST* you have gained a knowledge of the nature of the League and what it does, and you have read its purposes as set forth on page 6 of every issue. We would like to have you become a full-fledged member and add your strength to ours in the things we are undertaking for Amateur Radio, and incidentally you will have the membership edition of *QST* delivered at your door each month. A convenient application form is printed below—clip it out and mail it today.

.....1926

American Radio Relay League,  
Hartford, Conn., U. S. A.

Being genuinely interested in Amateur Radio, I hereby apply for membership in the American Radio Relay League, and enclose \$2.50 (\$3 in foreign countries) in payment of one year's dues. This entitles me to receive *QST* for the same period. Please begin my subscription with the.....issue. Mail my Certificate of Membership and send *QST* to the following name and address.

.....  
.....  
.....

Station call, if any .....

Grade Operator's license, if any .....

Radio Clubs of which a member .....

Do you know a friend who is also interested in Amateur Radio, whose name you might give us so we may send him a sample copy of *QST*?.....

..... Thanks?

# 90 VOLT "B" POWER UNIT \$12.75

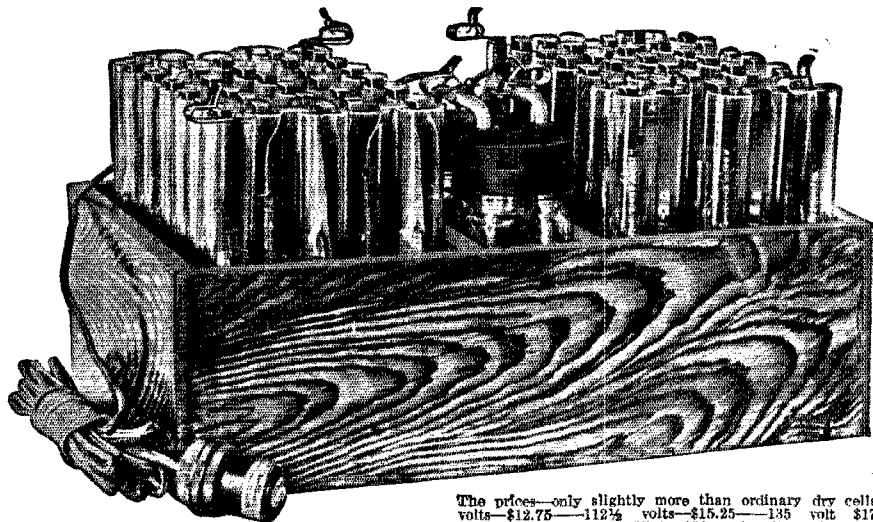

**RUMOR** has had it this **NEW HAWLEY ADVANCED POWER UNIT** was coming—and here it is. Hawley Storage "B" batteries have been standard for over 5 years and the same quality—the same standard of workmanship comprise this unit with its new ingenious hook-up and built-in-charger giving the utmost in B-Eliminator simplicity. Positively guaranteed not to give the slightest kind of trace of a hum or line noises. Simply plug it into your electric socket—and forget it. Any inexperienced person can hook it up in 2 minutes, as all voltages including those for any kind of detector are all plainly marked. Operates any 1 to 10 tube set. Does not contain any acid. It's so good—such true smashing value—that my 5 year old 30 day trial offer refund applies. You've got to see it—hear its operation to fully appreciate this statement.

The prices—only slightly more than ordinary dry cells 90 volts—\$12.75—112½ volts—\$15.25—135 volt \$17.50. For 105 to 120 volts, 25 to 130 cycle alternating current only. Special sizes to order of any voltage. Knockdown kits at still greater savings. All complete as above—nothing to purchase extra. Further covered in my regular 2 year guarantee. Arnie stocks—all packed—same day shipments and your order is all I need to speed it on its way to you. Simply say—ship C.O.D.—pay expressman its cost plus small transportation charges—and you'll thank me later—or write for my free literature, testimonials, etc.

**B. HAWLEY SMITH,**

324 Washington Ave., Danbury, Conn.

U. S. A., Mfr. of—"A" Power Units, "B" Power Units, "A" Storage Batteries, "B" Storage Batteries and A & B Chargers including Trickleers.

## For Transmission Assurance

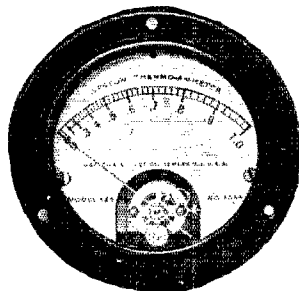

**TRANSMISSION** experts use Weston instruments. They give them the greatest assurance not only for their daily tests, but materially aid in solving their problems of tomorrow.

Model 425 Thermo-Couple instruments, originated by Weston, perfectly solve all

problems in the measurement of antenna currents. They overcome all objections to the hot-wire expansion type.

**WESTON** Model 301, 3¼ inch diameter D. C. Voltmeters, Ammeters and Milliammeters have the highest accuracy in panel instruments of their

size. Your own work in transmission needs the same assurance required by experts—who choose Westons. You will be interested in the new and more attractive prices on the Model 425 Thermo-couple instruments. Write us for circular "J."

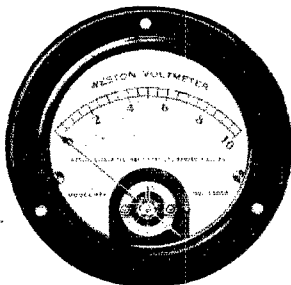

**WESTON ELECTRICAL INSTRUMENT CORPORATION**  
158 Weston Avenue, Newark, N. J.

STANDARD THE WORLD OVER

# WESTON

*Pioneers since 1888*

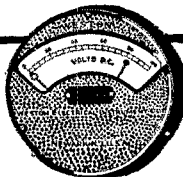
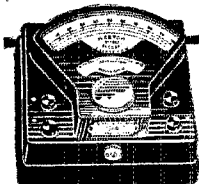

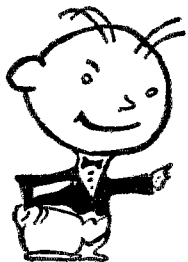

# Hello Gang!

Shake hands, I'm glad to meet you. I am "Dyner Dan," the "big wind" up at Nick's. And say OM let me say a word here now, when you want parts for your Ham transmitter or receiver let us know. We carry in stock all the standard stuff, such as Acme, Jewell, Allen-Bradley, Thordarson, General Radio, Etc. Our organization is run by Hams and we specialize in this line of equipment. We hope to have our new catalogue ready soon and will shoot you along a copy if you say the word.

Bst. 73's

(Dyner Dan)

(Dyner for DX)

## Nicholson Electric Co.

1407 First North St.  
Syracuse, N. Y.

## George Electric Company "B POWER UNIT" TYPE M

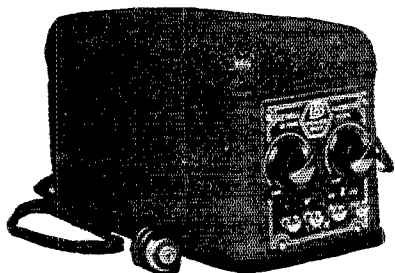

### Complete With Tube \$29.50

Our patented filter circuit is most efficient, delivering absolutely pure direct current, free from any hum or distortion. The Type M Unit is sturdily constructed, and will last as long as the best receiving set.

Variable resistances permit the selection of voltages to make your set work efficiently at all times. You can bring in distant stations with more volume, and your locals with purer tone.

This unit operates on 110 volt, 60 cycle A.C. It will deliver 180 volts, with plenty of current for a ten tube set or sets equipped with power tubes.

—FULLY GUARANTEED—

Our dealer will be glad to give you a demonstration. Write for further information.

**GEORGE ELECTRIC COMPANY,**  
756 Carleton Ave., St. Paul, Minn.

Dealers and Agents! Write today for attractive agency proposition

## World's Finest Radio BUG Improved Martin

Reg. Trade Marks  
Vibroplex  
Bug  
Lightning Bug

# VIBROPLEX

Trade Mark Reg. U. S. Pat. Off.

For Continental,  
Morse or  
Navy  
Codes

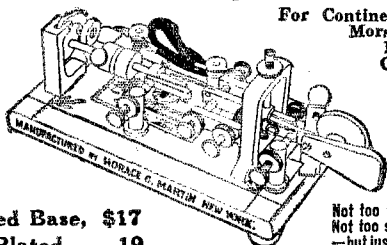

Japanned Base, \$17  
Nickel-Plated, 19

Not too fast—  
Not too slow—  
—but just right

## Get This BUG Now!

Now is the time to get your BUG. Be up-to-date—enjoy the many advantages of sending with this Improved BUG. You'll be amazed to find how easy it is to learn and to operate. Nothing can compare with this BUG in EASE and PERFECTION of sending. Over 100,000 users. Saves the arm, prevents cramp and enables the "ham" to send with the skill of an expert.

### Special Radio Model

Equipped with extra large specially constructed contact points to break high current without use of relay. Radio operators say fills a long felt want. Sent anywhere on receipt of price. Money **\$25** order or registered mail.

**THE VIBROPLEX CO., Inc.**  
825 BROADWAY NEW YORK  
104

SAY YOU SAW IT IN Q S T—IT IDENTIFIES YOU AND HELPS Q S T

## Cardwell

CARDWELL .00025  
Condensers \$1.25  
CARDWELL 2-Step  
Amplifier 10.00  
CARDWELL All-Wave  
Coupler, 150-3000 meters, 2.00  
Frank E. Etzel, 192 Water St.  
BROOKLYN, N. Y.

## FOR EVERY BEGINNER

THE SIGNAL  
PRACTICE SET

Complete in every detail with high grade key, true tone adjustable high pitch buzzer and brass code plate. R63 \$3.40



SIGNAL WIRELESS KEYS

R49 R62   
Strongly made with coin silver contacts. Brass parts polished and lacquered. Very reliable units.  
R48-1/4 in. K.W. \$2.80 R62-1/4 in. contact \$3.50  
R63-1/4 in. " \$3.70  
R64-1/4 in. " \$3.90

Signal Buzzer



R60  
Small neat high frequency type. Has standard resistance of 2 ohms. Black crystallized lacquer finish. Special resistances on quality orders.  
R60 \$1.25

We manufacture a complete line of telegraph instruments.  
**SIGNAL ELECTRIC MFG. CO., Menominee, Mich.**

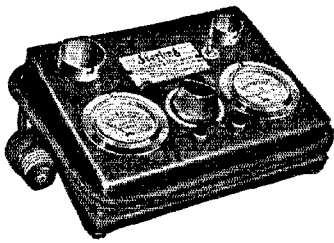

# Sterling Combination Tube Tester and Reactivator

The last word for  
all around  
Tube Service Work

Built especially to test all tubes and reactivate those that are thoriated. Used as a tester when tubes are purchased or sold and as a profit maker for store or service man. Plugs into 110-115 volt 50-60 cycle alternating current line and tests large and small tubes for amplification, including the new 300-A and 171 power tubes. Equipped with rheostat by which filament voltage is set at 3.0 or 5.0 volts. Adjusting this rheostat to the required filament voltage automatically adjusts plate voltage to the correct amount for testing. Any fluctuation in A. C. line voltage does not affect accuracy of test.

Plate milliammeter readings, obtained by pushing button, show tube amplification. Filament emission meter, in conjunction with switch lever and "test" "medium" and "high" taps, tests emission and shows amount of improvement after reactivation.

No trouble shooter or radio expert who wants to have the "last word" in service equipment can afford to be without this new Sterling Combination Tester.

- R-409 A. C. Combination Tester and Reactivator .....Price \$30.00
- R-411 Home Tube Tester for 201-A and 301-A tubes, including power tubes- Price \$7.50
- R-400 Home Tube Tester for 199 and 299 tubes, including adapters ....Price \$8.50
- R-406 "Universal" Tube Tester, including adapters .....Price \$18.00

The Sterling Mfg. Co.  
CLEVELAND, OHIO

# Leadership

with Benjamin Radio Products  
in Securing the Best Radio Results



All Benjamin Radio Products are of the same high standard as the far-famed Cle-Ra-Tone Sockets~

## Improved Tuned Radio Frequency Transformers

Space wound. Basket weave. Cylindrical. Highest practical air dielectric. Gives wonderful sharpness in tuning, better volume and purer tone quality.

2 1/4" Diameter Transformer  
Compact, especially desirable for crowded assembly. Eliminates interfering 'pick-up.'

Set of three, \$5.75. Single Transformer, \$2.10

3" Diameter Transformer  
Capacity coupling reduced to lowest degree. For use with .00035 Mfd. Condensers.

Set of three, \$6.00. Single Transformer, \$2.25

## Straight Line Frequency Condensers

Eliminates bunching of stations. Spreads the log evenly over the dial. Makes tuning easy. Adjustable turning tension. Compact. A beautiful instrument that not only improves reception, but adds to the good appearance of the set.



.00025 Mfd., \$5.00

.00035 Mfd., \$5.25 .0005 Mfd., \$5.50

## "Lekeless" Transformers

Uniform high inductance, low distributed capacity and low resistance. The external field is so slight that it permits placing coils close together without appreciable interaction.

Single Transformers, \$2.50

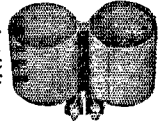

## Cle-Ra-Tone Spring Supported Shock-Absorbing Sockets

Spring Supported, Shock-Absorbing. Stop Tube Noises. The greatest aid to non-noisy operation. Contacts always clean.

75 cents each

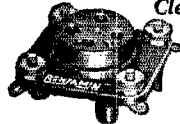

## Brackets Battery



An aid to simplification in set construction. Supports sub-panel, with room underneath for accessories and wiring. Plain and adjustable.

Plain, 70 cents per pair

Adjustable, \$1.25 per pair



Quick, positive, clean-cut make and break. When it's "in" it's "off," eliminating danger of wasteful use of battery.

30 cents each

## REWARDS FOR RADIO REASONERS

Awards for novel and original hook-ups, modifications of existing circuits; trade names; slogans. Write our nearest office for full details.

If your dealer cannot furnish you with Benjamin Radio Products send amount direct to our nearest sales office with his name and we will see that you are promptly supplied.

## Benjamin Electric Mfg. Co.

120-128 S. Sangamon St.  
New York: Chicago San Francisco:  
247 W. 17th St. 448 Bryant St.  
Manufactured in Canada by the Benjamin Electric Mfg. Co.,  
of Canada, Ltd., Toronto, Ontario

# FROST • FONES

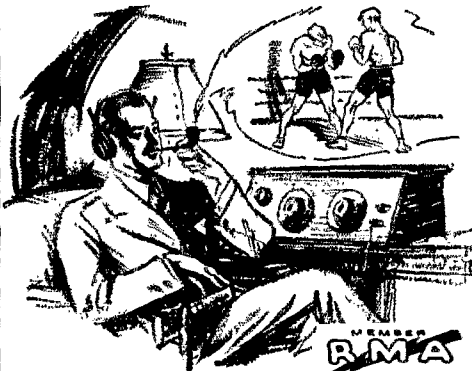

For Clearness, Quality  
and Distance

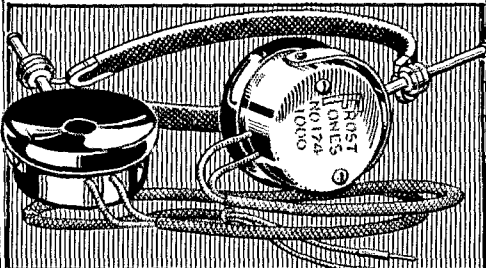

When there is something on the air that especially interests you and you do not want to miss a word, use a pair of **FROST-FONES**. You will get a quality of reception that you cannot get any other way—a clear, pure, natural and undistorted tone. Compare **FROST-FONES** with other makes, at your dealer's, and be convinced.

Prices, \$3.00 to \$6.00

## FROST-RADIO Super-Variable Resistance Units

These new high resistance units give a continuous graduation of resistance, smoothly, without steps or jumps. They are non-inductive, noiseless and wear-proof in operation. Even after long continued use there is no variation in resistance. Type 880 has two terminals and Type 890 three terminals, each supplied in a number of resistances. See them at your dealer's. Both types



Type 880

## FROST-RADIO PAN-TAB JACKS

The Pan-Tab represents the finest in material and workmanship ever put into a radio jack. Springs are heavier and the contacts more positive. Frame is nickel plated brass, hand buffed to a high finish. Prices 65c to 90c at your dealer's.



**HERBERT H. FROST, Inc.**

160 North La Salle Street

New York CHICAGO Los Angeles

for  
**Christmas!**



# Kingston "B" Battery Eliminator

Guaranteed to remove the battery nuisance and deliver clearer tone and increased volume. Provides three different voltages at the same time. Each tap adjustable over a wide range, making possible any desired voltage from 5 to 150, absolutely harmonizing "B" current supply to your set. Raytheon tube used as rectifier. No noise or vibration. Contains no acid or solution and will not get out of order. Operating cost negligible. A REAL Christmas gift.

At Your Dealer's

Price, complete \$35.00  
with Raytheon tube

**KOKOMO ELECTRIC COMPANY**  
KOKOMO, INDIANA



# HAM-ADS

## NOTICE

Effective with the July issue of QST the policy of the "Ham Ad" Department was altered to conform more nearly to what it was originally intended that this department should be. It will be conducted strictly as a service to the members of the American Radio Relay League, and advertisements will be accepted under the following conditions.

- (1) "Ham Ad" advertising will be accepted only from members of the American Radio Relay League.
- (2) The signature of the advertisement must be the name of the individual member or his officially assigned call.
- (3) Only one advertisement from an individual can be accepted for any issue of QST, and the advertisement must not exceed 100 words.
- (4) Advertising shall be of a nature of interest to radio amateurs or experimenters in their pursuance of the art.
- (5) No display of any character will be accepted, nor can any typographical arrangement, such as all or part capital letters, be used which would tend to make one advertisement stand out from the others.
- (6) The "Ham Ad" rate is 7c per word. Remittance for full amount must accompany copy.
- (7) Closing date: the 25th of second month preceding publication date.

THE life blood of your set—plate power. Powerful, permanent, infinitely superior to dry cells, lead-acid Bs, B eliminators. Trouble-free, rugged, abuse proof, that's an Edison Steel-Alkaline Storage, B-Battery. Upset electrically welded pure nickel connectors insure absolute quiet. Lithium-Potassium solution (that's no lie). Complete, knock-down kits, parts, chargers. Glass tubes, shock-proof jars, peppy elements, pure nickel, anything you need. No. 12 solid copper enameled permanently perfect aerial wire 75c 100 ft. Silicon steel laminations for that transformer 15c lb. Details, full price list. Frank Murphy, Radio 8ML, 6406 Carl Ave., Cleveland, Ohio.

25% to 35% discount to amateurs on receiving parts. No sets. Over two pounds data, circuits catalog—25c, prepaid. Also exchange new receiving parts you want for new parts—what have you? Weekly data bulletin—\$2.50 year, trial 20 weeks—\$1.00. Fred Luther Kline, Kent, Ohio.

COMMERCIAL ammonium phosphate. 40c per pound. You pay postage. A few new 203As, \$20 while they last. Duane N. Hadley, Shelby, Ohio. SCTD.

OMNIGRAPHS, vibroplexes, transmitters, keys, receivers, chokes, coils, meters, transformers, "S" tubes, transmitting tubes, rectifiers, wavemeters, eliminators. Bought, sold. Sell, trade 8 tube Super. \$50. L. J. Ryan, 9CNS, Hannibal, Missouri.

FOR sale one kilowatt Crocker-Wheeler 500 cycle motor generator 110V DC drive, shaft extended for AC drive. Condition excellent. Fifty dollars. R. M. Blair, SEB, 3934 Ivanhoe Ave., Norwood, Ohio.

GANG! Cooper-Hewitt Mercury Arc Rectifiers, new and guaranteed, \$11.75 by express only. Blueprint and details 25c. 50 watters, \$20.00 ea. Wilbur Gemmill, 434 N. Beaver St., York, Penna. 3AAO.

TWO new W. E. fifties \$26.00 each. UC1014, .002, 3000 volt condensers \$1.80. Few peanut "N" tubes \$2.25. Set four Sansamo Pressley Super transformers \$12.00. Karryradio portable case with loop and horn \$5.00. List \$15.00. Cardwell .00045 mfd. transmitting condenser \$6.00. All Amertran, Silver-Marshall parts special prices. Navy dynamotor 32-350 volts D.C., \$17.00. Add postage. 2BYJ.

FEDERAL Variometers (list \$4.00) \$1.75; German Head-phones (list \$6.00) \$3.95; R.E.L. choke coils .93; Tobe transmitting condensers (new type—working voltages) 1 mfd 1000 \$3.82; 2 mfd 1000 \$5.72; 1 mfd 2000 \$4.54; 2 mfd 2000 \$7.62. Tobe filter condensers (300 working volts) 4 mfd for output devices with UX-171 and similar power tubes \$3.10; Tobe hi-current resistors ideal for SAY YOU SAW IT IN QST—IT IDENTIFIES YOU AND HELPS QST

B-Eliminators and transmitters \$1.02. Aero low wave tuner kit \$9.87; tuned R.F. kit \$9.75. Hammarlund dual condenser \$5.97. Jewel meters. M. B. Spinoza, 27-k School St., Boston, Mass.

GENERAL Electric 24/1500 volt 350 watt 6000 RPM 112 segment ball bearing dynamotors \$35.00. With shaft for external belt drive \$38.00. Ideal for battery plants. Half voltage tap. Crocker-Wheeler 24/1500 volt 450 watt \$45.00. GE 12/350 volt 50 watt \$18.00. With shaft \$20.00. Navy SE 1012 receivers range 50-1000 meters, Navy precision wavemeters 125-2500 meters, keys, Crocker-Wheeler 500 watt 500 cycle motor generators, motor 110 volt DC and adapted for external drive. Westinghouse 27.5/350 volt dynamotors. Fotos. Henry Kienzle, 501 East 84th Street, New York City.

FOR sale—1500 volt 1 Kw. motor-generator set with 110 volt single-phase motor, also 15 volt, 45 ampere filament generator. J. C. Jensen, University Place, Nebraska.

EXPERIMENTAL RADIO by R. R. Ramsey Professor of Physics, Indiana University. The only scientific experimental manual. Endorsed by A.R.R.L. QST p29, June 24. Measure, adjust and perfect your set, 85 experiments, mimeographed. Price \$2.00 postpaid. QST or University Book Store, Bloomington, Indiana.

BETTER EDISON elements, welded connections 7c pair. Sample cell 10c. Paul Mills, Woodburn, Oregon.

HAMS: Get our samples and prices on printed call cards made to order as you want them. 9APY Hinds, 19 S. Wells St., Chicago, Ill.

SELL—Corona portable typewriter, A-1 condition, practically new, \$30. Will consider 15 dial omnigraph in trade. 9WX.

UV203, 3 meters, 2 transformers, helix, socket, condensers, rheostat, rectifier, microphone, etc., \$35. 2 filament "Audiotron" \$3. Rowe Kinney, 2357 Litchfield Rd., Shaker Heights, Ohio.

DODGE Radio Shortkut Users, of all degrees, during eight years demonstrate fundamental merit of Method. Licensed operators (other methods) raised receiving speed to 25 per rapidly. Raw beginners passed code exam in one week. Struggling learners stuck at 5-8 per jumped quickly to 12-15 and secured license. Progress as reported by licensed users in each radio district on request. Astonishing progress and quick results as reported by 200 licensed users, price 25 cents—but quarter coupon enclosed. Shortkut with Appendix and Better Key Work \$3.50 U. S. and Canada—elsewhere \$4.00. Money Order only. C. K. Dodge, Mamaroneck, New York.

FELLOWS—Good broadcast receiver. Four-tube Brown-ing-Drake surpassed five and six tube neurodynes—laboratory measurements! A tested six-tube B-D using standard parts—wind no coils, merely assemble—having two high-gain r.f. stages, not only one. Plans information—\$1.00. More volume, distance, selectivity. Worth recommending. Plans, 18-1900 meter receiver, does it all decently, standard parts, drill panel and assemble, \$1.00. L. W. Hatry, care Times, Hartford, Conn.

6BBV's entire 250 watt station at sacrifice, including new 250 watt W.E. tube, advance sync, four meters, etc. Complete, \$150. Also receiver and extras. J. Barsby, 1010 Bates Ave., Hollywood, California.

SELLING out: Complete 100 watt fone set. New circuit. Perfect modulation. Including all tubes and new double commutator ESCO motor-generator. \$450 takes it. If you want a real station this is your chance. Also 20 watt CW, fone set complete. \$150.00. Dan Moore, Jr., 5 A.O.Y. Newark, Ark.

CLOSING out—Kennedy 220 150-3500 meters with amplifier—Western Electric 7-A amplifier and horn. Beautiful console type mahogany cabinet for above with high and low voltage instruments—2 storage batteries, charger, charging panel and meters, all tubes included \$160.00. Kennedy 110 (200-30000 meters with 2 stage Kennedy amplifier), \$65.00 145v 1500 MA Edison \$15. 200 watt Acme power. \$15. 2 "S" tubes No. 4000-1, \$10 1, RCA 50H 0.3A choke, \$9. General Radio wavemeter 20-500 110, 1-0.2A Jewel DC meter, \$5. R. C. Smith, North Glenside, Pennsylvania.

FOR sale—or trade. 15 watt crystal control set. Motor Generator. Best of parts. Want 50 watt 250 tube and power transformer. All inquiries answered. SCPQ, 614 Buckeye, Hamilton, Ohio.

10 WATT transmitter for sale. Radio station 8BJT, 701 Walnut Ave., Scottsdale, Penn.

BREAK-IN relays: Heavy silver contacts. Will handle two K.W. Six volts operation. Ten dollars postpaid. Wesser, Alpena, Michigan.

COUNTERPHASE six kit—never used, \$30.00. Push pull power amplifier, All American, \$10.00. W. D. Fulton, Apollo, Penn.

FIRST check \$20.00 takes my 750 volt .2 ampere, 15 volt 20 ampere Crocker-Wheeler ball bearing Generator. Extended shaft with three gears for induction. Motor drive. Little used. P. Socolofsky, 34 Noxon Street, Poughkeepsie, N. Y.

SELL—four new 250 watters XL filament \$25. each. Emil Prandoni, Pekin, Ill.

WANT to memorize the wireless code? The Corydon Snyder code method, patented, is quickest. Send 10 cent coin to C. G. Snyder, 1243 Rosemont Ave., Chicago, Ill.

AMATEUR transmitting and receiving supplies. Send for catalog. Ron Wollard, Newark, Ohio.

A FEW Dollar Assortments left. Biggest bunch of small radio parts ever. Prepaid this month only East of Rockies. Headquarters for General Radio and other quality parts. Bargain list for the asking. R. P. Barrows, Columbia Road, Portland, Maine.

PURE aluminum and lead rectifier elements, holes drilled, brass screws and nuts, pair 1/16", 1" x 4", 13c, 1 x 6 15c, 1 1/4" x 6 17c, 1 1/2" x 6 19c. Sheet aluminum 1/16" \$1.00, 3/16" \$1.90. Lead \$1.00 square foot all prepaid. Silicon transformer steel cut to order .014", 10 lbs. 25 cents, 5 lbs. 30 cents less than 5 lbs. 35 cents per lb. 4 cubic inches to the lb. Postage extra. 1/2 cash with order—balance C.O.D. Edgewise wound copper ribbon .350" wide; 3 1/4" outside diameter 10c turn, 4 1/4" 13c turn, 5 1/4" 15c turn, 6 1/4" 17c turn, 7 1/4" 20c turn, prepaid. Geo. Schulz, Calumet, Michigan.

SACRIFICE—50 watt frame mounted transmitter, complete \$100. Cash talks. If interested send for photo and description. 9BSO, 1111 East Louisiana St., Evansville, Indiana.

SELL—Thordarson 5-watt transformer, \$5.00. Acme 1 1/2 H double choke, \$3.00. Bradlevstat, Bradlevometer, and the usual junk that collects, sell or trade cheap. Theodore Lucke, Le Mars, Iowa.

SELL—Tresco 175 to 20,000 meter receiver. SDFS, Fairgrove, Michigan.

BARGAINS—500 volt generator, Crosley receiver, short-wave tuner, other amateur equipment. Wanted—type-writer, storage battery, wavemeter and plate transformer. Write Howard Severoid, Huxley, Iowa.

FOR sale—Hard rubber panels. Five by twenty-six. \$50. R. F. coils for Neutrodyne, etc., \$50. Maynard J. Columbe, 8HD, Plattsburgh, New York.

WANT new or used UP1627, UP1653, UP1654 chokes. L. Pruchnicki, 713 Smith Street, Flint, Michigan.

ACME 600 watt plate and filament transformer \$15. Jewell 0-15 Thermo Ammeter \$5 or what you have. SAAI, 404 Sixth Ave., Butler, Penn.

QSL CARDS: During Xmas vacation the 8BJT press will be glad to print you some neat, clean-cut cards. Treat your station to the best. R. J. Mumaw, Care E. M. S., Harrisonburg, Va.

SEND for my bargain list on ham equipment. 9MV, Story City, Iowa.

WHAT'S a Ham's Christmas without something new for the other buster? Let the family know about it in plenty of time, also that 9ALD is the place where it's sold. If

you haven't it, we'll be glad to send you the "Hamalog", the original Ham Catalog, free. Lots of new items here, including DeForest Transmitting Tubes; REL Inductances, Wavemeters, Short Wave Receiver Kits; etc. See our display ad elsewhere, and don't forget to ask for the Hamalog. E. F. Johnson, 9ALD, Waseca, Minnesota.

SEND for your copy of the new "Ham-list", Price 4c. Curtis-Griffith 250-watt power-filament transformers 550 each side \$12.50. Thordarson 650-volt power-filament transformers for 5-watters \$6.90. Thordarson power transformers 350-550 each side \$11.00; 1000-1500 each side \$16.00. Edgewise Copper Strip 6-inch turn 12c; 4-inch turn 10c. Aluminum square foot 85c; Lead square foot 85c. Jewell 0-15 Voltmeters \$7.50; 0-500 Milliammeters \$7.50. Style UX210 7.5-wattors \$7.50. New "Ham-list" 4c. James Radio Curtis, 5-A-Q-C, 1109 Eighth Avenue, Fort Worth, Texas.

TANTALUM strip for rectifiers—radically new universally variable condensers—cross wound coils for Superheterodyne transformers and R.F. Chokes—Government long wave receivers, air condensers for transmitters, and Edison B B 4 batteries—2200-volt transformers—quartz crystals—Peaked 10 to 1 audios—Superhet & Power transformers—Transmitter B Eliminators—A B Eliminator parts—Chokes any size iron or air core—Filter condensers—Oscillator wavemeter drivers from battery or A.C.—Loud speaker coupling chokes and transformers—Jewell meters—Sales representatives wanted—Give Call for Catalog & Disc. Charles O. Snyder, Richmond, Indiana.

SHORT-WAVE transmitting and receiving apparatus. Big discounts and bargains in headphones and other standard equipment. For latest low-price list write 2APJ, 643-5 West 171st Street, New York City.

2CUZ selling out cheap. Write for list. Whittemore, Briggs Ave., Yonkers, N. Y.

EXTRA low-loss coils, double spaced No. 18 D.C.C. wire, lath-wound, celluloid strips, 12 cents per linear inch (8 turns). Also tuned radio frequency chokes for 40 meters. No. 28 silk covered wire on one inch tubing, 25 cents. C.O.D. Leslie A. Harlow, 3 Mayflower St., Plymouth, Mass. 1-AXI.

HAM headquarters—"curgri-co" 5-watt DX Babies \$3.15 postpaid. Mueller 150-watt input tubes \$15.00. Federal buzzers \$2.75. Potter 2000-volt 1-Mfd condensers \$2.50; 2500-volt 1-Mfd condensers \$3.25. Used bugs \$10.00. R. Curtis, 1109 Eighth Avenue, Forth Worth, Texas.

PEPPY "B" batteries. Build yourself a powerful plate supply unit with genuine Edison elements. Good peppy elements per pair 4 cents, drilled 4 1/2 cents, perforated hard rubber insulator 1/2 cent each, pure nickel wire 1 cent per foot, shock proof glass tubes 3 cents each, complete sample cell 20 cents, lithium potassium to make 5 pound solution, \$1.25. Completely assembled "B" battery in beautiful highly finished cabinet with panel and series parallel switch for charging, voltage taps, etc. 100 volts \$10.95, 130 volts \$14.25. Complete "B" battery charger \$2.50. Cash with order or C.O.D. Martin, 706 S. Ashland, Chicago, Ill.

NEW 275 volt d.c. generators 120 watt fine for fone will give up to 500 volts \$8. Slightly used 1/2 KW 500 cycle \$15. 200 watt \$10. 10 to 300 d.c. \$15. 30 to 300 d.c. \$8. 1/4 h.p. 32 volt motors d.c. \$8. 750 volt 250 watt used d.c. generators \$20. 1/4 h.p. 60 cycle a.c. motors \$12. Microphones \$1. No. 14 enameled solid \$4.75 per 100. New RCA 1015 transformers plate and filament \$11.50. UC 1803 condensers 50c, UC1881 \$1.50. Postage extra on all. Send stamp for list. R. Wood, 46-29 102nd St., Corona, New York.

A.R.R.L. sweater emblems make a fine Christmas gift to members. They are made of the highest grade black and yellow felt, 5" x 8" diamond. \$1 postpaid. No COD's. Eric Robinson, 135 Jefferson Road, Webster Groves, Mo.

BANK of nine 1 mfd. Western Electric Condensers \$4.50. 530 volt 150 watt generator coupled to 110 volt 60 cycle single phase motor \$35.00. 750 volt 200 watt generator coupled to 110 volt 60 cycle single phase motor, \$45.00. 2500 volt 2 kilowatt generator double commutator coupled to three phase 220 volt 1750 speed motor. 2500 volt 600 watt double commutator generator coupled to 110-220 60 cycle single phase motor, 1750 speed. Prices F.O.B. Chicago. James Smat, 1734 West Grand Ave., Chicago.

WANTED Omnigraphs, vibroplexes, 50-wattors, S-tubes. Price Griffith, 1109 Eighth Avenue, Fort Worth, Texas.

## Q R A SECTION

1AAP—Clifford A. Langworthy, R. D. No. 1, Westerly, R. I.

1AWJ—Walter H. Winchell, 55 Highland Ave., Newtonville, Massachusetts.

1BMG—Charles H. Stevens, 94 Prospect Street, Stafford Springs, Connecticut.

1CRA—Sidney Carter, 16 Balcarres Rd., West Newton, Mass.

2CBG—C. M. Radford, Slater Ave., Colonial Heights, Tuckahoe, N. Y.

2MK—E. F. Reynolds, Central Valley, New York.

4CV—Beman Beckwith, 721 S. Boulevard, Tampa, Florida.

4FO—C. A. Davis, P. O. Box 668, Winter Haven, Fla.

5AMT—H. R. Dugger, P. O. Box 367, Renner, Texas.

7IZ—E. V. Casey, Attalia, Washington.

8BEV—Wm. J. Wagner, Box 3, Bucyrus, Ohio.

8COJ—T. C. McFall, 218 Eleventh St., Alliance, Ohio.

8RD—C. H. Vincent, 12694 Northlawn Ave., Detroit, Michigan.

9AID—Clifford H. Buckshorn, Box 48, Route No. 1, Covington, Kentucky.

9AXZ—Fred Herman, 3632 N. Kedvale Ave., Chicago, Illinois.

9BXB—D. G. Bertalot, 1814 Elm Street, Rockford, Ill.

9DZW—H. W. Kerr, Little Sioux, Iowa.

9JZ—Chas. T. Temple, 6440 University Ave., Chicago, Illinois.

c2BB—C. J. Dawes, Pointe Claire, Quebec.

G15MO—Charles Morton, "Simla" Glastonbury Ave., Belfast, Northern Ireland.

z2BE—(ex z3AE) Syd Strong, Box 9, Gisborne, New Zealand.

z2BG—J. G. Tinney, 74 Kainui Road, Hataitai, New Zealand.

The following stations belong to members of the A.R.R.L. Headquarters gang. Mail for them should be addressed care A.R.R.L., Hartford, Conn.

1MK Headquarters	IDQ John M. Clayton
1AL H. P. Westman	1ES A. A. Hebert
1BAO R. S. Kruse	1KP F. Cheynev Beekley
1BDI F. E. Handy	1OA R. S. Kruse
1BHW K. B. Warner	1SZ C. C. Rodimon

### PRICES TALK AGAIN

PROMPT-RELIABLE SERVICE. Thordarson, filament and plate transformer for 7 1/2 watt transmitters. This transformer has 850 volt plate winding and 10 volt filament winding with center taps. SPECIAL PRICE \$6.25. Thordarson filament transformers, 80 watt for one to four 7 1/2 watt tubes, \$6.15, 150 watt, for one to four fifty watters \$7.95. Thordarson plate transformers 100 watt, \$10.95, 450 watt \$14.95. Acme transformers reduced. Acme 30 henry 150 mill choke \$16.20, 30 henry 300 mill \$22.00. Jewel 3 inch flush or panel mount meters, all sizes of milliammeters, voltmeters and ammeters. D.C. voltmeters and ammeters. SPECIAL \$6.00 each. All sizes of Thermo-couple antenna current ammeters \$9.50. Genuine Cardwell double spaced transmitting condensers cap. .00022, 3,000 volt breakdown voltage, SPECIAL \$3.45. Genuine Cardwell .0005 23 plate condensers \$1.20, .001, 43 plate \$1.80. R.E.L. transmitting inductance (double with rods) \$8.95, single \$4.65. R.E.L. plug-in coils \$3.50. RCA UC 1803 condensers, 10,000 volt breakdown fixed condensers for Hartley and tuned plate & grid transmitters for grid and plate blocking, SPECIAL \$4.50 each. UC 1846 \$1.00. Crescent Lavite 5,000 ohm transmitting grid leak \$2.20. Ward Leonard 5,000 leak 200 mill capacity \$1.85. Fleron lead-in insulators \$3.90. ARSCO coupled pancake inductance 20-40-80 meter \$4.45. Aero stort wave kit \$9.35.

All merchandise guaranteed and sold on a money back basis. It will pay you to deal with a brother ham.  
2MA 207 NEPTUNE AVENUE, BROOKLYN, NEW YORK

## HEY, HAMS! Here's Something to Crow About MOUNTFORD'S GUARANTEED "KROBLAK" Nichrome Wire Wound 10 Watt, 2 in.; 20 Watt, 4 in. RESISTANCES

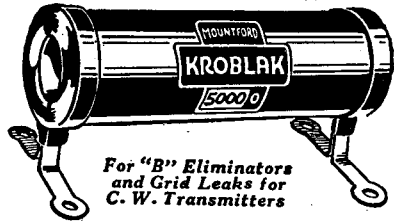

For "B" Eliminators  
and Grid Leaks for  
C. W. Transmitters

From 750 to 10,000 Ohms Price \$1.00.  
25,000 Ohms \$1.25. 50,000 Ohms, \$1.50.  
A Booklet of 5 "B" Eliminator Circuits Free  
with Kroblak's.

At your dealer's, postpaid upon receipt of  
price, or sent C.O.D.  
FREE Literature on Request.

C. E. Mountford, 465 Greenwich, N. Y.

Endorsed by All Leading

"B" Eliminator Manufacturers

## Become a Radio Operator

See The World. Earn a Good Income. Avoid Hard Work.

Learn in the Second Port U. S. A.

Radio Inspector located here. Positions plentiful. Splendid Climate. Other advantages to the student unequalled in any other American port.

Nearly 100 per cent of operators graduating on Gulf during past four years trained by MR. CLEMMONS, Supervisor of instruction. Every graduate secure position.

Day and Night Classes; enroll anytime. Write for Circular.  
**Gulf Radio School** 844 Howard Avenue,  
New Orleans, La.

## 5 IN 1 CONNECTOR

Licensed under Pat.  
1,557,245



With this ingenious and inexpensive device attached to positive and negative phone binding posts you can use from one to five pairs of phones on any radio receiving set. The spring socket grips any phonetip. Loose contact is impossible. Works while loud speaker is in operation.

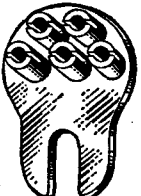

If your dealer cannot supply you we will mail you a pair on receipt of 25 cents.

DEALERS QUOTED ON REQUEST.

**SNOW & COMPANY**

Dept. QST. 149 Church St., New York.

## WHITMAN WORLD TIME DIAL

A Dial for attachment to Westclox "America" clocks or clocks of a similar size. Easily attached to the clock in a few minutes. From a clock, with this Dial attached, THE TIME IN ANY PART OF THE WORLD MAY BE READ AT A GLANCE. No Amateur Radio Station should be without one of these Dials.

Price sixty cents Postpaid (Stamps not accepted).

Full directions are sent with each Dial and a list of the standard times used by over 100 countries and possessions.

State whether the Dial is for use in Atlantic, Eastern, Central, Mountain or Pacific Time Zone. Canadian Patent 1926. Other Patents pending.

**P. L. WHITMAN**

P. O. Box 52 Halifax, N. S. Canada

# HALCO

## MAIL ORDER SERVICE

For Radio Transmitting Equipment

Ever since the first development of the Super-regenerative circuit with its unsurpassed sensitivity, attempts have been made to put it in a workable form—easy to control and free from critical and cranky operation.

The difficulties of this seemed so great that before long the circuit fell into disuse and experimenters turned their attention elsewhere to what they believed more fruitful fields. Now Edward B. Dallin, of the Cruft Laboratory, Harvard University, after a long period of research, has succeeded in designing a Super-regenerative Short-Wave Receiver which is easy to control.

This receiver can be readily put together by anyone and, what is more interesting, can be readily operated by anyone. It is simple and not difficult to wire and the parts complete are not expensive.

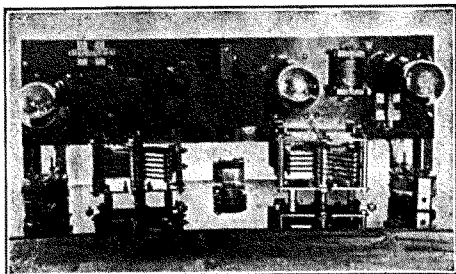

Mr. Dallin's Receiver is being offered in kit form by HALCO MAIL ORDER SERVICE as the DALLIN-HALCO SUPER. We claim for this receiver:—(1) Sensitivity of an entirely new order; (2) Simplicity of operation; (3) Compactness; (4) Low cost.

Think of the joy of making tape-records of your DX achievements! The DALLIN-HALCO SUPER—the most sensitive Receiver for short-wave reception in existence—permits this and many other good things.

Reception is not limited to CODE. Voice and music are being heard REGULARLY from England, Germany and other distant points.

Highest grade parts in kit form, ready to wire, with complete diagrams and instructions, \$47.00.

Remember, HALCO MAIL ORDER SERVICE sells the DALLIN-HALCO SUPER KIT exclusively.

HALCO MAIL ORDER SERVICE, 132 Hanover Street, Boston, Mass., places at the disposal of the Radio amateur a comprehensive and prompt source of supply for modern Radio transmitting equipment. Descriptive matter and prices will be gladly sent you on request if you mention QST.

**HALCO MAIL ORDER SERVICE**  
132 Hanover Street Boston, Mass.

## FOR YOUR CONVENIENCE QST'S INDEX OF ADVERTISERS IN THIS ISSUE

Acme Apparatus Company	93
Acme Wire Company	94
Advance Electric Company	80
Aero Products, Inc.	76
Aerovox Wireless Corp.	74
Airgap Products Company	81
Allen-Bradley Company	72, 98, 101
Allen-Rogers, Inc.	83
Aluminum Company of America	69
Amateur Radio Specialty Co.	84
American Sales Company	76, 92, 96, 98
American Transformer Company	68
Amrad Corporation	89
A. R. R. L. Application Blank	102
A. R. R. L. Handbook	67, 80, 3rd cover
A. R. R. L. Messing Blocks	100
Baldwin Sales Company	67
Barawik Company	112
Benjamin Electric Company	105
Bunnell & Co., J. H.	36
Burgess Battery Company	4th cover
Burton Rogers Company	92
Cardwell Mfg. Corp., Allen D.	95
Carter Radio Company	67
C. E. Mfg. Company	70
Central Radio Labs.	102
Crescent Radio Supply Co.	96
Crosley Radio Corporation	74
Cunningham, Inc., E. T.	2nd cover
DeForest Radio Company	99
Deutschmann Co., Tobe	88
Dongan Electric Mfg. Co.	84
Dudlo Mfg. Company	83
Eastern Radio Institute	76
Electrad, Inc.	92
Electric Specialty Co.	78
Elkon Works, Inc.	87
Ensall Radio Laboratory	94
Eppe's	82
Etzel, Frank E.	104
Fansteel Products Co.	100
Formica Insulation Co.	2
Frost, Inc., Herbert H.	108
Garrison-Rumely	101
General Instrument Corp.	72
General Radio Company	81
George Electric Company	104
Gray & Danielson Mfg. Co.	79
Grebe & Co., Inc., A. H.	4
Gulf Radio School	109
Halco Mail Order Service	109
Hammarlund Mfg. Company	96
Hammarlund-Roberts	68
Hughes Electric Company, Beni	91
International Resistance Company	93
Jacobs, Chas. F.	95
Jenkins & S. E. Adair, J. E.	78
Jewell Elec. Inst. Corporation	97
Joinson Company, E. F.	100
Karas Electric Company	71
Kokomo Electric Company	80
Lynch, Inc., Arthur H.	80
Mace & Son, F. F.	78
Mario Electric Company	86
M. B. S. Sales Company	96
Morris Register Company	78
Mountford, C. E.	109
National Carbon Company	111
National Company	75
Nicholson Electric Company	104
Pacent, Electric Company	82
Penn Radio Sales Company	86
Polymer Mfg. Corporation	80
Premier Electric Company	96
Radio Corporation of America	1
Radio Engineering Labs.	91
Radio Foundation, Inc.	82
Radio Surplus Corporation	82, 88, 94
Randolph Radio Corporation	86
Raytheon Mfg. Company	77
Sangamo Electric Company	79
Seattle Radio Laboratory	76
Signal Electric Mfg. Company	104
Silver-Marshall, Inc.	72
Smith, B. Hawley	103
Snow & Company, Albert E.	109
Spartan Electric Corporation	101
Sterling Mfg. Company	105
Stromberg-Carlson Telephone Mfg. Co.	95
Supertron Mfg. Company	100
Thordarson Electric Mfg. Company	73
Transmitting Equipment Company	70
Trelect Sales	90
Utility Radio Co.	67
Vibroplex Company	104
Ward-Leonard Electric Co.	98
Well's Curiosity Shop	86
Westerland Corporation	90
Weston Electrical Instrument Co.	103
Whitman, P. L.	109
Wireless Specialty Apparatus Co.	90
X-L Radio Labs.	98
Yaxley Mfg. Company	74
2MA	109



Eveready's exclusive  
Layerbilt construction *makes*  
*this the most economical*  
*of "B" batteries*

IMPROVEMENT on top of improvement has been the history of Eveready Radio Batteries. Here, in the radically different Eveready Layerbilt, is the "B" battery which tops them all. The ability of this battery to give you unrivaled service and economy is due to its unique internal design. Instead of the usual assembly of round cells, it is built of flat layers of current-producing materials pressed firmly together. This construction makes use of the spaces now wasted between the round-type cells and avoids the usual soldered wire connections. Eveready Layerbilt is every inch a

battery. This exclusive Eveready Battery development packs more active chemicals in a given space and enables them to produce more current and give longer life.

This HEAVY-DUTY EVEREADY LAYERBILT BATTERY gives twice the service of the smaller Light-Duty batteries and greatly reduces your "B" battery operating cost.

Use Eveready Layerbilts on any set, and get not only this extra service, but also — the greatest "B" power operating economy — the utmost in "B" power dependability — D. C. (direct current) in its purest form, which is so necessary for pure tone quality.

Tuesday night means Eveready Hour—9 P. M., Eastern Standard Time, through the following stations:

- |                  |                |
|------------------|----------------|
| WEAF—New York    | WTAM—Cleveland |
| WJAR—Providence  | WWJ—Detroit    |
| WEEI—Boston      | WGN—Chicago    |
| WEAG—Worcester   | WOC—Davenport  |
| WPT—Philadelphia | WCCO—St. Paul  |
| WGB—Buffalo      | KSD—St. Louis  |
| WGAE—Pittsburgh  | WRC—Washington |
| WSAI—Cincinnati  |                |

**EVEREADY**  
**Radio Batteries**  
*—they last longer*

*Manufactured and guaranteed by*  
NATIONAL CARBON CO., INC.  
New York San Francisco  
Canadian National Carbon Co., Limited  
Toronto, Ontario

# GOOD NEWS FOR QST READERS

## BARAWIK CO. INAUGURATES NEW AMATEUR DEPARTMENT

Something new to radio fans is the installation by The BARAWIK COMPANY of Chicago, one of the pioneer institutions in the radio industry, of a special amateur department. It will appeal primarily to amateurs already in the field, who desire to secure from one reliable source, all the supplies and equipment necessary for short-wave transmission and reception, and also makes it possible for outsiders to learn more about the fascination of amateur work.

Under Personal Direction  
of F. J. Marco, 9ZA



This special amateur department of the Barawik Co. will be under the experienced and capable direction of F. J. Marco, owner of amateur station 9ZA, well-known in amateur and general broadcasting circles, and the designer of the Bremer-Tully Counterphase Six, Aero short wave coils, several successful makes of broadcast receivers and a score of popular radio accessories. The services of this well-known radio engineer will be at the disposal of customers of the Barawik Co.

## New Barawik Radio Guide Featuring Short Wave Receiving And Transmitting Equipment

The Barawik Co. has just issued its new 1927 Radio Guide consisting of 164 pages of radio equipment of practically every known make and description. Included in the special amateur section of the Guide will be found the newest sets and kits for short wave transmission and reception, and a host of the equipment necessary to make amateur work more economical, effective and alluring.

### Everything in Radio

The Guide further gives a complete and comprehensive listing of the newest designs and models in factory-built radio sets, kits, parts for the latest, newest, well-known circuits of the world's leading designers, accessories, power amplifiers, B eliminators, socket power units and the newest wrinkles in accessories and radio equipment—in fact, everything worth while in radio and electrical goods. Several new departments of merchandise, such as auto supplies, electrical appliances, work-shop equipment, phonographs, wiring material, etc., are also shown. The savings in price range all the way to 50% and are very much worth while.

A free copy of this new 1927 BARAWIK GUIDE is available to all readers of QST and their friends. Simply mail the handy coupon below—or write a letter or postcard. Please include the name of another fan when writing. Give your call letters, if any!

## ORDER YOUR SHORT WAVE SET OR KIT NOW!

Here are a few selections taken from the Barawik Guide

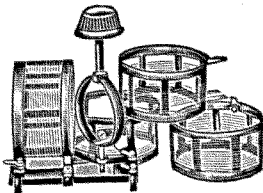

Bremer-Tully Short Wave Kit

This is the short wave outfit with which 2NZ copied the first news of Byrd's successful flight over the North Pole. Consists of 4 plug-in coils and base; adjustable, rotating primary; space-wound coils on skeleton framework; fixed capacity-controlled tickler at filament end of coils; covers 12 to 200 meters with B-T L-7, 150 mmf. condenser and L-B, 250 mmf. regeneration control.

3MQ 4241. Price Complete \$6.80. Postage 10c extra.

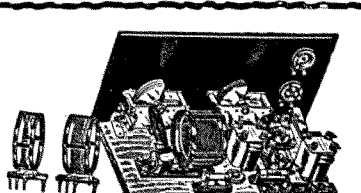

Barawik-Aero Short Wave Receiver  
Designed by F. J. Marco

A new short-wave receiver designed by F. J. Marco, 9ZA, using Aero coils and highest grade component equipment to insure the best short-wave radio set that can be built. Covers 15 to 130 meters and adapted to the reception of short-wave broadcast programs, or the actual amateur relay work. A model of performance. Complete with assembly and operation directions.

103-MQ 5951—Complete set as illustrated \$42.95

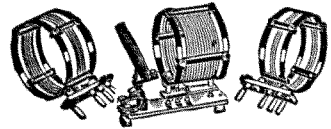

Aero Coil Short-Wave Kit

15 to 130 meters Interchangeable Coil Tuner.

Designed by F. J. Marco.

These coils used in the Barawik-Aero and Call Book Aero short-wave receivers. Best of electrical and mechanical construction. Spaced with correct size wire, supported by minimum of solid dielectric. Fixed, capacity-controlled tickler at filament end of secondary. Adjustable antenna coupling. Positive, noiseless contact by General Radio Plugs. Covers entire U. S. and foreign waveboards. Range with 140 mmf. tuning condensers, either Cardwell, Karas, Gen. Radio, etc.—15 to 130 meters.

3 MQ 3522—Per Set.....\$10.57  
Postage 10c extra

MAIL THIS COUPON NOW

*The Barawik Co.*

540-571A Monroe St. Chicago, Ill.

BARAWIK CO., 540-571A Monroe St., Chicago, Ill.  
Send me my copy, free, of your new 164-page  
1927 Radio Catalog and Guide with new Amateur  
Section.

Name .....  
Address .....  
Friend .....  
Address .....

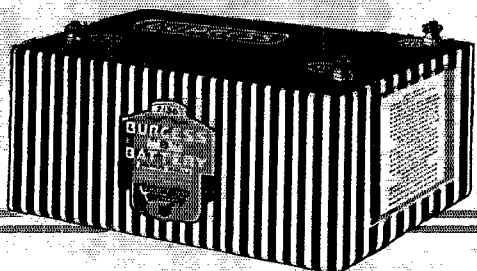
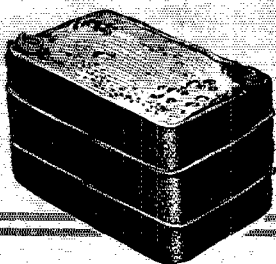

# Here's the oldest and newest— How old is yours?

That black little package of pitch and cardboard is the Granddaddy of all dry "B" batteries—the first of its kind in the world.

Many old-timers remember it. For a few months we will publish on the back cover of Q S T the call of every "ham" who sends us a radio-gram, a card or letter telling how many years he has used our batteries. Send yours today. Address Burgess Battery Co., Madison, Wisconsin.

## Burgess Batteries are used in these "ham" stations

GODLEY	1FD	2CWR	4EQ	5ADD	5YK	6CTP	8AHC	8BPD	8DME	9BZM	9DUV
BYRD	1ES	2CYX	4FD	5ADO	5ZAL	6DBH	8AGI	8BPV	8DPA	9CAG	9DVR
MacMillan	1H	2DX	4FJ	5ADY	6AEB	6DAI	8AGU	8BRA	8DOZ	9CBJ	9DYL
WILKINS	1KP	2EP	4FM	5AJJ	6AEP	6DDF	8AJ	8BRC	8EW	9GBY	9DZI
1AAC	1KZ	2EV	4FM	5AJJ	6AKM	6DIN	8AM	8BRS	8GX	9CCO	9EAH
1AAQ	1LM	2EY	4JN	5AJJ	6ALR	6DDZ	8AM	8BTH	8JB	9CCO	9EBJ
1AAP	1MO	2JG	4KD	5AKY	6AM	6HU	8ANB	8BYN	8KF	9CDO	9EDU
1ABP	1MY	2JK	4KF	5AML	6AM	6IH	8ATI	8CCN	8KP	9CDO	9EEZ
1AER	1SZ	2EG	4KM	5ANL	6BBE	6RO	8ATV	8CI	8RB	9CET	9EFO
1AFA	1VZ	2LE	4L	5AVG	6BBQ	6TO	8ATX	8CIB	8ZE	9CFU	9EGH
1AID	1WQ	2NZ	4L	5AVG	6BBQ	6TU	8AUB	8CM	8ZG	9CHE	9EGU
1AIT	1XAM	2PF	4L	5AVG	6BBQ	6TQ	8AVB	8CMY	8ZZ	9CLD	9EHK
1AMH	1XC	2OU	4L	5AVG	6BBQ	6TQ	8AVB	8CN	9AAV	9CLD	9EHO
1ANQ	1YB	2PL	4L	5AVG	6BBQ	6TQ	8AZD	8CN	9AD	9CLJ	9EJI
1ASU	1ZS	2WC	4L	5AVG	6BBQ	6TQ	8AZU	8COR	9AE	9CMA	9EJY
1ATJ	2ACV	2WM	4L	5AVG	6BBQ	6TQ	8BAD	8CVR	9AGG	9CN	9ELT
1AUC	2ADH	3AAI	4L	5AVG	6BBQ	6TQ	8BAJ	8AGU	9AGG	9CP	9ELT
1AVL	2ADL	3ACN	4L	5AVG	6BBQ	6TQ	8BY	8BYM	9AGU	9CPK	9EP
1AW	2AEF	3ACP	4L	5AVG	6BBQ	6TQ	8BC	8DDN	9AGV	9CPO	9GR
1AWW	2AER	3AEA	4L	5AVG	6BBQ	6TQ	8BDG	8DDN	9AIV	9CPY	9GK
1AZJ	2AET	3AFA	4L	5AVG	6BBQ	6TQ	8BF	8DDU	9AK	9CPY	9GK
1BBM	2ALS	3AJQ	4L	5AVG	6BBQ	6TQ	8BFG	8DED	9AMZ	9CRW	9H
1BGO	2ANB	3ALV	4L	5AVG	6BBQ	6TQ	8BFM	8DJG	9APM	9CSB	9H
1BDB	2AQB	3ALV	4L	5AVG	6BBQ	6TQ	8ACU	8DJG	9AQ	9CWL	9H
1BEZ	2APK	3APF	4L	5AVG	6BBQ	6TQ	8ACV	8DJG	9ARU	9CWA	9H
1BGC	2ASB	3APV	4L	5AVG	6BBQ	6TQ	8ACV	8DJG	9ASG	9CWZ	9H
1BGO	2AVV	3AOT	4L	5AVG	6BBQ	6TQ	8ACV	8DJG	9ASG	9CYG	9H
1BHM	2AWQ	3BAY	4L	5AVG	6BBQ	6TQ	8ACV	8DJG	9AVJ	9CVY	9H
1BIG	2AX	3BDZ	4L	5AVG	6BBQ	6TQ	8ACV	8DJG	9AVL	9CYO	9H
1BIZ	2AYU	3BGI	4L	5AVG	6BBQ	6TQ	8ACV	8DJG	9AXZ	9DAY	9H
1BLW	2AZU	3BMN	4L	5AVG	6BBQ	6TQ	8ACV	8DJG	9AYO	9DB	9H
1BMK	2BAR	3BNU	4L	5AVG	6BBQ	6TQ	8ACV	8DJG	9AZN	9DDP	9H
1BOD	2BBG	3BWI	4L	5AVG	6BBQ	6TQ	8ACV	8DJG	9AZV	9DGM	9H
1BUB	2BBW	3BWT	4L	5AVG	6BBQ	6TQ	8ACV	8DJG	9BAG	9DH	9H
1BVB	2BEE	3CA	4L	5AVG	6BBQ	6TQ	8ACV	8DJG	9BBX	9DHJ	9H
1BVL	2BNL	3CGL	4L	5AVG	6BBQ	6TQ	8ACV	8DJG	9BDW	9DHP	9H
1CJX	2BO	3EH	4L	5AVG	6BBQ	6TQ	8ACV	8DJG	9BE	9DIG	9H
1CKP	2BOW	3OL	4L	5AVG	6BBQ	6TQ	8ACV	8DJG	9BHT	9DOA	9H
1CMP	2BV	3OP	4L	5AVG	6BBQ	6TQ	8ACV	8DJG	9BIT	9DK	9H
1CTI	2CKA	4B	4L	5AVG	6BBQ	6TQ	8ACV	8DJG	9BMX	9DLK	9H
1DB	2CKA	4B	4L	5AVG	6BBQ	6TQ	8ACV	8DJG	9BNA	9DNG	9H
1ES	2CP	4DD	4L	5AVG	6BBQ	6TQ	8ACV	8DJG	9BOL	9DRS	9H
1FD	2CQZ	4DK	4L	5AVG	6BBQ	6TQ	8ACV	8DJG	9BSX	9DRS	9H
1FN	2CRB	4DM	4L	5AVG	6BBQ	6TQ	8ACV	8DJG	9BVO	9DTG	9H
	2CVR	4EK	4L	5AVG	6BBQ	6TQ	8ACV	8DJG	9BWA	9DTK	9H



# BURGESS RADIO BATTERIES

# To the Man Who Would Like to be an Amateur and Doesn't Know How to Start—to the New Recruit to Short-Wave Radio.

*Here is a book written to order for you, to tell you how to do these things*

It starts at the beginning and tells  
what an amateur is,  
what the League is,  
what amateur radio is,  
how to be an amateur,  
how to learn the code,  
how to understand what you hear,  
how to get your licenses,  
how to build a simple station,  
how to build a better station,  
how to operate your station,  
how the A. R. R. L. works,  
how to handle traffic,  
and it winds up with an  
appendix filled with enough extra dope to keep  
you busy for the next ten years.

*It has twice as many words as the average book,  
all of them directed right at you and your case.*

And the price of the A.R.R.L. Handbook is only \$1, postpaid

**American Radio Relay League**  
1711 Park Street, Hartford, Conn.



# The Communications Department

F. E. Handy, Communications Manager  
1711 Park St., Hartford, Conn.

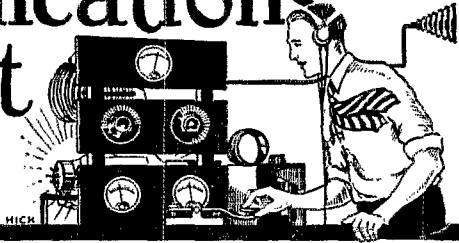

## "How Do We Get This Way?"

By J. J. Long, Jr., S8BX and G. Gray, ex3CG

HAVE you had people ask you, "What do you hams talk about, and what good does it do you?" I've been wondering what some of the gang do talk about, and what good it does do them. After a careful survey, we have concluded that some hams don't know what to say or do when they sit down at the key. QST has raved and raved about this "nil hr cul 78" stuff for two years but it seems to make little difference. It is hard to reform old offenders. The new gang more readily gets the correct dope on what constitutes a good operator and once the habit is formed, becomes an asset rather than a liability to the A.R.R.L.

There are many stations on the air that have a well regulated method of "doing their stuff" with the key. Why not most of us?

Here are a few pointers that will make you "a pleasure to meet on the air", instead of being tuned out. Take the point of view you have when listening to others. Start on the lower end of the band and start coming up. First to greet your cans, we will say is an RAC note calling CQ. He is easily readable and only sends THREE CQ's and signs his call SMOOTHLY and DISTINCTLY. You at once say, "There is a good station. Let's call him".

Call him slowly with good spacing, about TEN times, (or less) then sign THREE times, finishing "AR". The well-operated station comes back, calls you TWICE, signs ONCE, says R GE OM SIGS R58 QSS NIL, QSB RAC ES STEADY. He may have a MSG., in which case, he says "HR MSG QRV? K". You then call him ONCE, sign ONCE and say "RK". Then he sends his message. In no case will he send each word twice unless you ask him to. Usually one can get a message easier if it is sent single, and the message repeated if necessary.

If you get the MSG ok, say, "R NR—". Then ask how DX is or what time he usually gets on the air so you can work him again.

These hit-or-miss QSO's are the bunk and if you should meet 8PDQ at any time and he remembers the QSO he had with you, and you say, "I don't remember when I worked you", it puts you down as a haphazard ham and he does not feel any too good himself, not being remembered. Every A.R.R.L. man should take this for a station motto, "It is not how MANY or how FAR I work, but how RELIABLY I work, that counts."

Suppose you are tuning and hear a wabbling AC note calling CQ about "forty per" on a rotten hack-saw-blade stickwiper-type key. After you make up your mind to stick it out and find who the "haywire" chap is, he signs his call sloppily so you guess it is 2No.%. Do you try to get MSGS off to him? Well I should say not! You immediately tune him out and hunt for a better station. Did you ever stop to think that that is just what the other fellow would do to you if you resorted to such crummy practices? That's just exactly what he'd do!

One of the worst offenses of most of the gang is the sending of superfluous signals, calling and signing after having once established communication with a station. In these days of had QRM, especially on forty meters, the less we clutter up the air the better. All the old timers who are over their DX craze, and have decided to get some real fun out of the old outfit, are the ones I am appealing to, to start the ball rolling on this business of suppressing superfluous signals. We must actually tell stations how they sound when we work 'em. When they start this RRRRR ——— ND ND QRM QRM PSE

PSE QTA QTA AGN AGN OM OM BLAH BLAH stuff, we must come back and tell 'em they "don't know their onions" if they do such things. You don't think it will work? I know it will work because I've tried it on quite a few already and the next time they work me, they have laid off that stuff. Sorry to say, there are still a few hams on the air who don't get QST or belong to the A.R.R.L. and the only way to spread this epidemic of decent operating practice is to tell 'em when you work 'em. You don't have to be tactless in doing it either—just call the matter to their attention for the good of the game.

Here are the fine points all summed up: Have a good steady QSB and use a regular type of telegraph key. Keep on ONE WAVE all the time. Never work a fellow unless you intend to TALK to him. Use standard abbreviations. Cut out unnecessary stuff. Try to be original on the air. Don't be so original that it is disgusting to the other fellow but treat your friends on the air as you would any friends. Let's start a craze on, "how long we can stay QSO with any particular station and how many real friends we can make by amateur radio". Let's go now, gang, and don't forget to keep your log OK.

C U on the air and 78 "Jay es GF".

## The CQ Problem

By Dan B. Lamb, 6ANO

THE CQ problem is getting to be serious again. For a time there was a definite improvement but now it seems that the whole gang has gone wrong because some can't or don't use CQ with judgment in order to get best results.

On one occasion the writer was listening to two hams chewing the fat. One kept reporting "QRM" until the other chap got tired of the same old story and asked what was wrong because he had traffic to clear. In reply the first operator made it clear that a CQ artist was mussing up the air right on the traffic man's wavelength and that his long winded CQ's were holding things up. So the messages were never put through. Furthermore, the poor fellow who sent the CQ's never raised a soul either. After the first five minutes of waiting for him to sign they hunted up someone with more common sense.

Not only does it sound better to hear the standard "three times three" CQ but also it is more productive of results in raising stations. It is not fair to the fraternity as a whole to monopolize one wavelength with a string of CQ's that do not mean anything. If a short CQ is sent with the sign given at frequent and regular intervals it will be most effective.

Why not learn to CQ correctly and improve your results by working more stations in the time you spend at the set?

## Emergency Power Supply

THE desirability and necessity for amateurs having in readiness an emergency power supply was demonstrated at New Orleans not very long ago. The Louisiana Section was visited by a tropical hurricane of great intensity causing millions of dollars property damage and cutting off all telegraph and telephone communication with the stricken area. As soon as news of the storm reached New Orleans, S.C.M. Freitag (5UK) and Mr. Seibold (5QJ) went on the air in an effort to secure news and to get in touch with amateurs in the affected storm area. Amateurs in the danger zone were either put out of business and had no emergency set, or they were asleep on the job. 5UK kept a watch far into the

night but his repeated calls and QSTs were fruitless. 5QJ was forced to abandon his efforts as soon as the power lines in his neighborhood were put out of business, thus lessening the chances of accomplishing things by amateur radio. Although 5UK had another transmitter hooked up and ready to operate on B-battery plate supply, his power did not go off. Ex5AA stood at his post at the local broadcasting station (WSMB) for thirty-eight consecutive hours giving such advance reports as could be secured from ships in the Gulf via the Tropical Radio Company (WNU) and the Naval Station (NAT) and was instrumental in saving many lives.

Although 5QJ was unable to work into the storm zone (Morgan City), he did make contact with 5HZ at Houston, Texas and arranged hourly schedules. A great deal of credit should go to 5HZ and 5QJ for the precise and conscientious way in which they did their duty until the danger period was over. Schedules were kept to the second so that traffic could be handled in case the wires went down between these two points.

While such storms are not a daily occurrence they are liable to come at any time in the Southern states. In the North, sleet storms and crippled wire service threaten public safety during at least three months of the year. It is impossible to tell just when there will be a call on amateurs to render assistance. The situation in times of emergency is a serious one. The entire question is one of preparedness for the individual station. Shall we be ready or not if and when an emergency arises?

Every amateur should give thought today to the installation of a set capable of doing emergency work. If you live along the line of a railroad you should get in touch with the local representative of the railroad so he will communicate with you in case you can help in an emergency. If not, you can at least put in an emergency transmitter at your station and be ready to help railroads, newspapers, or Red Cross in time of emergency. When the crisis arises, volunteer your services.

**PREPARE YOUR STATION TODAY!**

—F. E. H.

**ARMY-AMATEUR NOTES**

**2ND CORPS AREA**—All amateurs in New York, New Jersey and Delaware who are interested in the army net should send their station card, letter or other form of memorandum to the Signal Officer, Second Corps Area, Governors Island, N. Y., with a notation to that effect. This applies especially to amateurs who may thru some oversight, not yet have received an acknowledgment to a previous request for assignment to an army-amateur net. 100 amateurs have thus far been appointed and issued certificates of assignment to the various nets. The Brooklyn-Staten Island Net is working in good shape on weekly schedules. 2APD, 2ADO, 2ARM, 2CRB, and 2CLA made a record of 100% in handling the cipher messages. It's great sport, too! 2UF, 2HJ and 2KS are new principal Net Control Stations with 2ANV, 2VW, and 2CDR as alternates. 2SC will soon have 500-watts xtal-control on both 40 and 80 meters. The monthly meetings of the Hudson Division are being held in the Armory, 39 Whitehall St., New York City and a large number of the army-amateur gang is attending the meetings. At the first meeting of the season held Oct. 25, Major James and Captain Autrey spoke on the importance and purpose of A-A work. After Army-Amateur Representative 2PF outlined the organization and function of a net the rest of the evening was devoted to an informal traffic hamfest. ch9TC and u6HM were present and were prevailed upon for a few words.

**4TH CORPS AREA**—4TS, 4RR and 5UK are active in the organization of the Army-Amateur Radio Nets. Certificate has been issued to 5DL as principal N.C.S. When WZD became inoperative, government traffic was handled through 4QA and 4HU. The address of Mr. J. Morris, A.R.R.L. Representative for the 4th Corps Area is now 1765 North Decatur Rd., Atlanta, Ga.

**5TH CORPS AREA**—8SV, 9MN, and 8AMD volunteered to communicate with IWF located at the Radio Exposition in Boston, but were unable to do so on account of unfavorable atmospheric conditions. An interesting time is promised amateurs working in the 5th Corps Area and component nets this winter. A-A Representative 8BYN and Capt. Gardner of Fort Hayes had a lengthy conference and there will be something doing soon. Much useful information will be sent from AK4 on 40 meters and schedules will be kept with Army Amateur Radio Stations Monday

nights and perhaps some other nights. Please keep in touch with 8GZ or 8BYN as much as possible. More volunteers are solicited.

**7TH CORPS AREA**—Organization of the amateur radio system in this Corps Area continued with slight progress. Two-way communication was established between Corps Control station 9DR, and the Army Amateur Control station at Fort Monmouth. A schedule was maintained.

**8TH CORPS AREA**—A New Mexico net has been organized. The stations are as follows: Principal N. C. S.—5AK, 5ARN, 5GU, 5AQR, and 5AID; alternates are 5AGN, 5ARN, and 5AWH. More amateur stations are needed in New Mexico, Colorado, and Arizona. Just drop a line to 5ZAE, who will give you full information on the army net in your state.

**OFFICIAL BROADCASTING STATIONS  
CHANGES AND ADDITIONS  
(Local Standard Time)**

Call	7.00 pm	10.30 pm	12.30 pm	Days of Transmission
1BVB*	—	—	—	Daily
1BZ	39.5	—	—	Mon. Wed. Fri.
6BXD	40	—	—	Mon. Wed. Fri.
8EU***	—	—	—	Wed. Fri.
9AYK**	88	—	—	Tues. Thurs.
9CGY	80	—	—	Thurs.

\* noon and 11 p.m., 41 meters  
 \*\* 1 p.m., 41 meters  
 \*\*\* 6.45 p.m., 84 meters

**Navy Day Honor Roll**

AS announced in the October issue, Navy Day was observed on October 27. On that evening eight stations sent code broadcasts to all amateurs. These were sent on scheduled time and on the various short wavelengths as previously announced.

A good number of reports were received at headquarters, the greatest number of which were on NRRG. From this it is probably safe to conclude that this station was the easiest of the eight to pick up. The remaining stations line up according to the number of reports received as follows: NAR, NRRL, NISS, NKF, NPC, 1AW, and NPG.

1AW, NRRG, and NRRL operated on amateur wavelengths and therefore were handicapped by a good deal of amateur interference during the transmission of the broadcast. Several reports were received stating that these stations were heard but could not be copied on account of heavy amateur QRM. NAR, NISS, NKF, NPC, and NPG, worked BELOW the amateur 40-meter band on officially-assigned Navy wavelengths and fared better, although a few cases of interference from amateurs out of the band were noted.

The best over-all performance can be credited to NRRL. A greater number of words were copied correctly from this station than from any other station. Reports received on NRRL total many thousands of words. NAR ranks second in this respect with NISS (in port at Cherbourg, France on Navy Day) a close third. NISS was widely copied and put through a good solid signal to almost every part of the United States.

The Honor Roll has been made up from copies of broadcasts sent in by the amateurs participating. The names of these amateurs have been arranged according to the greatest number of words correctly copied. The ten amateurs listed first will receive a letter of commendation from the Chief of Naval Operations.

Call	Name	Address
NRRL	F. H. Schnell	Madison, Wisc.
2FN	C. K. Atwater	Upper Montclair, N. J.
8FKM-NM	Wilbur C. Cross	Conneaut, Ohio.
9CM	Edward N. Fridgen	L'Anse, Mich.
9DUZ	H. B. Miller	Mishawaka, Ind.
8BYV	Elvin J. Beall	Newman, Calif.
NRRG	Wm. Justice Lee	Winter Park, Fla.
1BDV	James P. Saunders	Salem, Mass.
8BBQ	Frank Macik	Pasadena, Calif.
2CRB	J. Goldstein	Brooklyn, N. Y.
2DY	John J. Long, Jr. and Wm. Brown	Bound Brook, N. J.
1RF	Clifford A. Harvey	Brookline, Mass.
1WJ	Robert G. Seyl	Brookline, Mass.
9DBW	Paul E. Griffith	Northfield, Minn.
1AJK	A. E. Linell	Worcester, Mass.
1BLW	Albert R. Champlin	Westerly, R. I.
8DME	Charles J. Heiser	Auburn, N. Y.
3FW	L. C. Herndon	Baltimore, Md.
9BDA	L. M. Matthews	McClure, Ill.

1BDQ Norman H. Blake  
 4PF Henry I. Middleton  
 9EHF Lorin W. Bristol  
 1ZAC Ralph P. Day  
 G. C. Barney  
 1FD James L. Hubbard  
 2WM William Leyh  
 60F E. L. Lamoureux  
 4PP Harry H. Rung  
 9CSB Carl F. Schultz  
 2EP Arthur C. Bates  
 8VE F. B. Westervelt  
 8ATZ-8SI G. W. Murphy  
 5AUS Floyd Lindsey and  
 Norman Willis  
 2AER John Hollywood  
 3ZM S. Delbert, Jr.  
 WBBY M. B. Paine  
 6ANO D. B. Lamb  
 1AEL Charles P. Kenyon  
 2ACY C. E. Bedell

E. Providence, R. I.  
 Hendersonville, N. C.  
 Aurora, Ill.  
 W. Millbury, Mass.  
 Providence, R. I.  
 Norwalk, Conn.  
 Richmond Hill, N. Y.  
 Riverside, Calif.  
 Waynesville, N. C.  
 Wilmette, Ill.  
 Schenectady, N. Y.  
 Pittsburg, Pa.  
 Salem, Ohio  
 De Queen, Ark.  
 Red Bank, N. J.  
 Media, Penn.  
 Charleston, S. C.  
 Mesa, Ariz.  
 Providence, R. I.  
 Schenectady, N. Y.

SUW, 8DRV, 8BN, 8MF, 8VT, 8DGX, 8WO, 8AVX. Everything possible was discussed in the time available. 8BN, 8AAB, 8CEP, 8DNR, 8MF, 8DZB, 8GW, 8DRV, 8TF, 8BMD, 8CLD, 8AVX, 8GC, 8DN, 8DX, 8CLL, 8AUX, 8AZD, 8API, 8FX, 8RX, 8SX, 8BA, 8CAV, 8COW, 8GU, 8BV, 8DNT, 8BRV, 8WO, 8XBK, 8BHH, 8FY, 8JX-RX, 8ATT, 8BJ, 8VT, and 8RD were among those present.

A new radio club has been formed at Battle Creek, Mich. The first meeting had an attendance of twelve members, and more are expected to come out as soon as things are organized. The members will be glad to do any work which will further the interests of amateur radio.

MISSOURI—The gang in St. Louis operated a 40 meter transmitter at the St. Louis Radio Show recently, and succeeded in stirring up a good deal of interest in the visitors. Good work was done by all the bunch. 9DLB, 9DUD, 9BCK, 9ZK-AAU, 9BHI, 9BBK, 9BLG, 9DMT, 9AOT, 9DOE, 9TY, and 9ELY operated the station (9AK) in proper turn. 9BHI, 9AOT, 9BEQ, 9DMJ, 9BBK, and 9DOE relayed the traffic from 9AK to distant points.

MONTANA—The Butte Radio Club now boasts 291 members. The club has been doing good work in the matter of tracing power leaks and other sources of interference in the city. The last meeting of the club was held Nov. 12.

NEW YORK—The first annual banquet of the Radio Club of Rochester for all the hams of Western New York was held Halloween night at Fagan's plantation, Rochester. Over fifty of the gang turned out. After a vy QSA chicken dinner there was a talk on interference by Mr. H. J. Klumb. This was followed by movies and jazz and a station tour began at 11.30 p. m. 8DDL, 8AHK, 8DSI, 8BEN, 8BGN and 8ALY were all inspected during the "wee sma' hours" ending with an old fashioned hamfest at 8ALY's. A new secret organization was organized at 3 a. m. The gang were sufficiently recovered from the initiation at one o'clock Sunday afternoon to break up the hamfest with the vowed intention of attending the Central and Western N. Y. convention in Rochester in 1927. More power to 8MC, 8ALY and 8AHK who made the affair a success!

ONTARIO—The Western Ontario Amateur Radio Association held its first annual banquet Oct. 22. After dinner, which was served at the Bungalow Tea House in London, speeches were given by the president (9HT) and vice-president, (3LW). Games and dancing followed the speeches.

OREGON—The Benson Tech Radio Club of Portland has started out this year by rebuilding the transmitter. They recently held an election of officers with the result that 7CN, 7FE, 7NP, and 7JC will head the club for the coming year.

PENNSYLVANIA—The Amateur Transmitter's Association of Western Pennsylvania recently held a smoker at which they elected their officers for the coming year. These are 8AGQ-DHU, 8AAX, 8CEO, 8OW, 8CES, 8AIO, 8BT, 8CTF. On the new Board of Directors are 8CKM, 8OC, 8ZD, 8AJU. The club did some fine work with a transmitter at Pittsburgh's first annual Radio Show. On Oct. 15, the A.T.A., and the Golden Triangle Radio Association met with the Oakmont High School Radio Club. Addresses were given by Mr. F. E. Handy of Headquarters, Director E. C. Woodruff, and SGM Gilbert Crossley. A novel feature of the entertainment was the showing of radio movies, and of slides of amateur stations in the vicinity.

QUEBEC—The gang at Montreal has been running a booth at the recent radio show there, and managed to put over a good bit of publicity for the cause of amateur radio. The management of the show complimented them on their booth, and said that it was really the feature of the exhibition.

SOUTH DAKOTA—The Sunshine Radio Club of Platte has already held four meetings this season. The club members have financed a new transmitter which will soon be in operation.

WISCONSIN—About 25 A.R.R.L. members who are attending the School of Engineering of Milwaukee are organizing a new amateur radio club. Code classes are being conducted to enable the neophyte members to qualify for their "tickets" as brass-pounders.

Since the last issue of QST, additional information has been received regarding the work of amateurs during the recent Florida disaster. 1BHS, 4MV, 2HA, and 4TX all did their part toward getting messages through from the stricken area. 4SB came back on the air after quite an absence, and helped greatly. The members of the Indianapolis Radio Club obtained front page publicity in newspapers of that city for their work.

### CLUB ACTIVITIES

ALBERTA—Members of the Alberta Radio Experimenters Association gathered at the St. Regis Hotel, Calgary, to welcome A. A. Hebert from Headquarters. After the 30 hams present had enjoyed the banquet that had been prepared, all adjourned to the local Naval Reserve rooms where a smoker was held. Mr. Hebert discussed the League and QST, and the workings of the A.R.R.L. in detail, and we feel that his visit will remain long with the fellows present.

CALIFORNIA—The Santa Clara County Amateur Radio Association put over a dandy convention. Now they are about to move into new club quarters, as the present ones are inadequate. During Christmas vacation a series of tests will again be run from Mount Hamilton, it is hoped. This time power will be used profusely, and many records should be made.

The Western Amateur Radio Association of Oakland was on the job with the S. F. gang and helped in handling the A.R.R.L. booth at the Radio Exposition. One member of the club recently handled a message written entirely in German which was delivered at its destination in Germany letter perfect.

CONNECTICUT—The Twin City Radio Club of West Haven held a very enjoyable banquet October 28. SGM Nichols, A. L. Budlong of Headquarters, and Mr. Doolittle were the principal speakers. The club has recently held an election of its officers for the coming year, and they are: IBOA, IBAU, 1BQH and 1AUK.

GEORGIA—The Atlanta Radio Club is on its feet again, and hopes to have a very active season. Fifteen men attended a reorganization meeting, where plans for the future were discussed.

ILLINOIS—The Chicago Radio Traffic Association installed a transmitter in their booth at the recent Chicago Radio Show, in an attempt to increase public interest in amateur radio. About 800 messages were originated, and a large number of BCLs were thus introduced into amateur traffic handling. The traffic committee of the club is again meeting regularly, and the news sheet is soon to resume its appearance.

The New Trier Radio Club of Kenilworth, Ill., recently elected 9CSB, 9AKP, 9ELK, 9AYA officers for the coming year. The club is on the air most of the time.

INDIANA—The Indianapolis Radio Club, after doing some fine work at the Indianapolis Radio Show, put on a ham fest for the out of town hams. At the show, they had a transmitter in operation, and handled a large number of messages for the BCLs, succeeding in interesting many of them in amateur radio. A new code class for hams breaking into the game started December 1st.

LOUISIANA—The Caddo Radio Club of Shreveport, La., has a new club house complete, which is being furnished and fitted up with a transmitter. The club expects to be on the air soon. 5ANL, 5QZ, 5QT, 5UK and 5ANP are already on the job handling traffic effectively with the gang.

MANITOBA—The Winnipeg Radio Traffic Association is laying plans for an active winter season, and is going to lay particular stress on efficient traffic handling. Recently a convention was held at the Marlborough Hotel in Winnipeg, and a talk given by Mr. A. A. Hebert, of Headquarters. The convention was a big success, one or two hams coming from great distances to attend.

MICHIGAN—The transmitting amateurs of Michigan and Ohio held a banquet and gabfest Oct. 24 and report a great time. After a fine dinner, several technical talks were given by 8CU, 8RD, 8CLD,

Frederick Best—IBIG

13 E. Crescent St.

Augusta, Maine

Orig. 214 Del. 94 Rel. 377 Total 685

BRASS POUNDERS' LEAGUE

Call	Orig.	Del.	Rel.	Total
5TW	421	211	698	1330
IBIG	214	94	377	685
IBMS	66	114	396	576
SCNX	182	54	330	576
9BFF	30	22	450	502
6BBQ	66	30	346	442
4SB	234	112	—	346
8DNE	88	10	225	324
1ATJ	10	16	290	316
4VS	301	5	4	310
6ANO	4	2	297	303
2AK	274	3	—	277
1UE	28	33	200	261
8BAH	14	17	223	254
9RR	212	7	16	235
di-IBD	58	152	18	228
6RW	19	162	44	225
1BKV	5	13	201	219
8AYP	80	96	40	216
1AIT	10	24	174	208
1ATV	38	39	130	207
1BHS	9	18	180	207
8EU	35	44	126	205
9ELT	185	5	10	200
90FK	56	31	112	199
1BFT	83	24	84	191
9DWN	17	3	170	190
9AGG	31	7	152	190
3ZO	4	21	182	188
9EK-XH	74	29	82	185
1AYJ	43	37	101	181
9SS	180	—	—	180
3ADE	22	6	148	176
9DXZ	41	31	88	160
1AID	65	42	50	157
2CYX	81	42	31	154
1AHV	23	31	100	154
3BWT	65	20	68	153
80BM	34	17	97	148
1YC	12	14	108	136
6PW	5	—	130	135
2ANX	25	30	78	133
1BVB	21	16	94	131
1AJM	92	7	31	130
1KY	11	27	91	129
8CAB	110	9	4	123
2BCB	—	—	122	122
9ACA	—	—	120	120
1ABA	14	10	96	120
8BSZ	11	14	94	119
1ADW	55	54	8	117
9EFK	6	3	107	116
1ALP	70	21	20	111
9CSB	11	8	92	111
9CIA	27	68	13	108
9BWN	12	5	92	109
5DL	60	26	22	108
5AMO	26	14	68	108
8AML	10	—	98	108
1NK	15	11	80	106
7PU	17	80	9	106
9CAA	13	17	76	106
8AJU	8	2	96	106
9ARA	9	12	84	105
9ACX	54	10	40	104
9IX	74	7	22	103
9CZC	1	5	96	102
8AGO	16	7	79	102
1AVL	20	3	78	101
1MR	77	1	22	100

We again urge everyone to get busy at the key. Give 5TW, IBIG and IBMS some competition and put your station in the B.P.L. If you work the key enough and handle your traffic on schedules with reliable stations you stand just as good a chance of getting that Traffic Trophy as the next fellow. Go to it, OM!

This month 5TW leads the B.P.L. by virtue of handling and reporting more messages during the past month than any similar amateur station in the entire country. 5TW has four operators on the job. By regularly keeping the tubes hot, night after night, the 1,000 mark was bettered this month—the first time any station has topped that figure for a long time. FBI!

In accordance with the rules governing the award of the Traffic Trophy (which are enumerated in revised form in this issue) the starred rectangle goes to the operator who single-handed puts through most messages during the reporting month. The distinction between the rules for the T.T. and the B.P.L. is thus made apparent. At stations manned by several "ops" it is necessary for each one to keep track of his message totals independently in order to compete for the Trophy.

IBIG made the starred rectangle for the second time and is all lined up for the Traffic Trophy. He gets the second position in the B.P.L. IBMS gave him a lot of competition and almost carried off the honors boosting his station from eighth to third place in the B.P.L.

The New England Division claims still further honors this month. Miss Lorentson (1AID) and Miss Hannah (1KY) both rate places in the Brass Pounders' League. While other Divisions have boasted YL operators one seldom hears them on the air. This is a feather in the cap of the New England bunch—showing the gang to be 100% brass-pounders including the two most active YL-operated stations in the country.

The Traffic Trophy

The Trophy is a valuable and beautiful plaque to be awarded the amateur operator who handles the greatest number of bona-fide messages for three consecutive months. The Trophy valued at a figure between \$150 and \$200 will be suitably engraved with the name of the winner.

The big prize is offered to an individual operator—not to a station which may have one or more operators. Any A.R.R.L. member holding an operator's license and operating an amateur station, is eligible. If an operator of a station where there are several ops wishes to compete for the Trophy a separate count of the messages handled by this operator must be kept and an affidavit furnished stating the number of messages handled by the individual operator. Each month the operator in the lead shall be listed in the starred rectangle to show just who is in line for the award. Message reports shall be sent through the Section Communications Managers each month. It is very important that the message file be preserved each month. Although these monthly reports are accepted on honor, the message file of the winner must be verified by the Section Manager and the Communications Manager before an award is made in order to insure fairness to other contestants who might otherwise question the award. The operator who receives the prize must be an "amateur" operator in every sense of the word. Operators who are paid for their services cannot compete for the plaque. The messages must be handled in accordance with good A.R.R.L. practise. Messages held longer than 48 hours and messages having the same text sent to more than one addressee (rubber stamp type) will not be counted in verifying the winner's message file. Please remember that the contest (first announced in February 1925 QST) is one of operating skill and not one of station equipment.

## GMD

The members of the Dyott-Roosevelt Memorial Expedition are travelling up the Sepotuba River in canoes as we write this report. It has been necessary to reduce baggage and personnel. Operator Bussey continues to use the low power portable set on 37.5 meters with a "pure D.C." note. It is not known definitely when the big 500 cycle set will get on the air. Several U. S. amateurs have handled traffic for the expeditions. 2FJ operated by 2APV worked GMD direct. 2UK, 2TP, 2AMJ and 2ADG have taken messages addressed to the New York Times and effected delivery, the traffic in each case being routed through one of the following Brazilian amateur stations: 1AM, 2AG, 1AK, 1AA, 2AF, 2GRB reports working SQIX direct and it is possible that this call is among those assigned to the Roosevelt expedition in addition to those listed last month. Please do what you can to keep this expedition in contact with home reporting hearing or working any or all expeditions out to A.R.R.L. Headquarters for QST.

### NOTICE!

To all A. R. R. L. Members of the Pacific Division and to all A. R. R. L. Members of the Iowa Section of the Midwest Division.

At a meeting of the Section Managers and the Pacific Division Director held at the Pacific Division A. R. R. L. Convention at San Jose, the existing conditions in each Section were taken up and an agreement for re-sectioning the Division was reached. A petition from A. R. R. L. Members in Arizona for a separate Section there has also been approved by the Pacific Division Director and the Communications Manager. The names of the several Sections and the territory included in each is hereby indicated as follows:

The *Sacramento Valley Section* includes the following counties of California: Del Norte, Siskiyou, Modoc, Trinity, Shasta, Lassen, Tehama, Plumas, Glenn, Butte, Sierra, Calusa, Sutta, Yuba, Nevada, Sacramento, El Dorado, Placer, Alpine, Yolo.

The *San Francisco Section* includes the following counties of California: San Francisco, Marin, Sonoma, Mendocino, Humboldt.

The *East Bay Section* includes the following counties of California: Lake, Napa, Solano, Contra Costa, Alameda.

The *Santa Clara Valley Section* includes the following counties of California: San Mateo, Santa Clara, Santa Cruz, Monterey, San Benito, Merced, Stanislaus, San Joaquin, Amador, Calaveras, Tuolumne, Mariposa.

The *Los Angeles Section* includes the following counties of California: Mono, Madera, Fresno, Kings, Tulare, Inyo, San Luis Obispo, Kern, Santa Barbara, Ventura, Los Angeles, San Bernardino, Riverside.

The *San Diego Section* includes the following coun-

ties of California: San Diego, Imperial, Orange. (Amateurs in this Section are requested to continue to send reports to the Headquarters of the Los Angeles Section until an official for the San Diego Section takes office.)

The *Arizona Section* includes the entire State of Arizona.

The *Nevada Section* includes the entire State of Nevada.

The *Hawaiian Section* includes the entire Territory of Hawaii.

The *Philippine Section* (provisional) includes the entire Philippine Island group.

The death of the Hawaiian Section Manager, the resignation of acting S. C. M. Adams of what was formerly Section 6 of the Pacific Division, the creation of new Sections of the Pacific Division, and the resignation of S. C. M. Huber of the Iowa Section of the Midwest Division, makes it necessary to call for nominating petitions from A. R. R. L. Members of the Sections concerned so that an election for a permanent leader to fill the existing vacancies in each Section may be held as provided in the Constitution and By-laws of the A. R. R. L. (By-laws 7). League members with active stations can readily determine where to send their reports each month by reference to page 3 of QST where temporary (\*) or permanent officials of each Section are listed.

*Nominating petitions for Section Communications Managers are hereby solicited from A. R. R. L. Members of the following Sections:*

*Section Valid petitions must be filed on or before:*

Sacramento Valley	Noon, March 2, 1927
San Francisco	Noon, June 2, 1927.
East Bay	Noon, Jan. 3, 1927.
San Diego	Noon, Feb. 2, 1927.
Arizona	Noon, Jan. 3, 1927.
Hawaiian	Noon, Feb. 2, 1927.
Philippine (provisional)	Noon, Jan. 3, 1927.
Iowa	Noon, Jan. 3, 1927.

The closing dates for receipt of nominating petitions in the Sections listed is given above. The petition must be filed at A. R. R. L. Headquarters on or before the time announced to be considered valid. The proper form for nomination was shown on page 45 of April 1926 QST. The candidate and five signers of a nominating petition for Section Communications Manager must be members of the A. R. R. L. in good standing. At least five of the signatures on the petition must be the authentic signatures of members of the League or the petition will be thrown out as invalid. Members are urged to take initiative immediately, filing petitions for the officials of each Section now operating under temporary officials or having the office of S. C. M. vacant, so that the work of organization can go forward everywhere without further delay.

—F. E. Handy, Communications Manager.

## DIVISIONAL REPORTS

### ATLANTIC DIVISION

**E**ASTERN PENNSYLVANIA—SCM, H. M. Walleze, 8BQ—Traffic suffered at the hands of the Lights, but the Section is better organized, anyway. E. L. Maneval, the mighty 8EU, dived into League work on another scale—that of Chief Route Manager for the Section; Official Observer and Official Broadcasting Station. He has a Grebe CR-18 perking, so watch your QRH or sloppy operating. QSO him on 40 or 80 for assignment on the routes heing formed. He wants to hear from all the consistent relay men.

Our BPL gang almost flopped flat. Only 4 and low totals. 8EU leads. 40% reporting are on 80 m., handled 75% of the traffic, 40 m. had 50% who handled 15% and the 10% on either two or three bands chased the 40 m. gang with the balance. 3ZO is short of ops which cut their total badly.

8BSZ is at his books again. 8EU built a new radiating system. 8ADE wants our Section to beat the So. Sect. of the Pacific Division, which was the only gang to trim us last month. 8licker did his part. 8BRT is going in the B. C. game. 8BFE is learning to pound the Ivory (with one hand, while he pounds brass with the other). 8AVK failed us this month but was hunting, I guess. A 50 watter has 8CMO worried. School takes up 8BIR's time now but he tickles 8DQG a little. 3LM is active. 8ADQ hit 'em up this month. 8HD lost his skeds somewhere. Anyone see them? 8ALE was appointed Principal Radio Station of the 79th Div. 8AIY entered the

same class. A busted flivver kept 8SM busy. HI, QRM from school didn't slow 8AWT up much. 8CW is keeping Heiser company at 8DQG. 3BLP has his Xtal rig on 40 now—his total flopped, too. Death in 8AFQ's family kept him off. Sorry, OM. A MG went west for 8AUV. 8AKW says his battery supply has RAC beat a mile. 3NP handled foot ball scores with 8DQG. College set 3LW back too. 3AIG failed us also but is helping boost 8XE's totals. (Not so good for us, OM, HI). 3BPQ wonders who the GH-1FG is he QSO'd. 3AY is busy erecting a 200 m. antenna. Cole says 40 is the bunk for traffic, anyway! 3VF craves more traffic. Pound it to him, gang. Another 200 m. station will blossom forth in 8PY, but he wonders where all those birds are on that band. (So do I, OM). A transformer went up for 8RT, but his new break-in is FR. 3ZO is still burning lots of KW's if the traffic was lower. 8CGZ is trying to talk a bird, signing "XXX" out of his QRA. QRM of some kind hit 3ZM hard. 8AVL blew and replaced his 50. It's nice when you can do it that way—snap, and a new one in service. A 250 left for 3BIT and he snapped two in. 3BMS is back from Europe and ready to go. 8BQ pounded the ole mill about all month.

Let's get busy an' swamp the Pacific gang next month.

Traffic: 8EU 205, 3ZO 188, 8ADE 176, 8BSZ 119, 8CMO 81, 8AWT 79, 8ADQ 60, 8AVK 60, 8CDG 33, 3LM 30, 8BFE 26, 8ALE 22, 3SM 20, 8DQG 20, 3BIT 16, 8HD 15, 3AIY 15, 8AKW 14, 3AY 12, 8AUV 10.

SBQ 10, SBLP 8, SAIG 8, SLW 6, SPY 6, SNP 5, SVF 5, SAVL 5, SBFL 4, SBQP 4, 3AFQ 3, SBRT 3, SBIR 3, SCW 2, SRT 2, SZM 2.

DELAWARE—MARYLAND—D. OF C.—SCM. A. B. Goodall, 3AB—Maryland: Reports are meager which is probably due to the change in the reporting system. SAEA, after a long absence, is coming to the front again on 80 meters. 3LL, filled the old electrolytic rectifier and went to it strong on 80 meters. 3RF reports giving 20 meters a tryout, but employs 38 meters regularly. 3ACW is still experimenting with antennas. 3OP is still sailing the seas, but when he comes to town, it's all YL and no radio. 3FY uses an H tube and gets satisfactory results. 3VI is coming back on the air. We've missed, old 3VI. 3BUR had a mast come down but it goes right up again. He's a sailor by occupation and then lets the antenna carry too much sail in the wind. 3APV has changed from the old homestead and is now located at Wilkinsburg, Pa. with the call 3APC. Washington thereby loses an active amateur.

District of Columbia: There have been two remarkable happenings in the District. The first is the transformation of 3CAB from a pure experimentalist to an active brass-pounder handling over 100 messages a month. He likes the change and so do the rest of us. The second happening is the creation of 3GP using a quarter K. W. tube with crystal control. Until a few weeks ago, he was a broadcast listener. 3HWT reports the old Atlantic Coast Line is falling back into step which means that 4JR is again lining up with 3BWT, 3EU and the rest of them. 3NW has shut down steam a little to rewire and rebuild. 3ASO, whose traffic report is listed below, handles all messages on phone, 171 meters, crystal control. 3JO burned out a 201A and then put in a 208A.

Traffic: Maryland: 3AEA 10, 3RF 9, 3RUR 3. D. of C.: 3BWT 153, 3CAB 123, 3AB 89, 3NR 35, 3BKT 34, 3ASO 10, 3JO 2.

WESTERN NEW YORK—SCM. C. S. Taylor. SPJ. The gang are on the job stronger than ever, with messages and DX from everywhere. What has happened to the traffic hounds in Buffalo. Many complaints have been received that no traffic can reach the stations here. 3ADE, 3UL and 3NT are the only ones reporting. Thanks to them for saving Buffalo's reputation this month.

3ABG has schedules with 2DX Dunday, 6:45 P. M. —is also installing a BC station in Lutheran Church in Ithaca, and has been handling traffic and attending school. 3ADE has been working the foreigners again, working Australia, and British South Africa, also handling traffic. 3AHC has worked Italian 1AU. He is building a crystal control set and handling traffic. 3AIL is handling traffic using 50 watter on 40 meters. 3AKC stabs aigs coming in from 7 districts. Now using Hertz antenna and transmitter poking out well. Handling quite a bit of traffic. 3AKS has worked Australia and was heard in Europe. 3ANK has a new QRA with new station on 40 and 80, reports several new stations coming through soon, also handles traffic and worked 30 8th dist. stations.

3ARG reports 3AFQ using Hertz and new 50 watter working everything that hears him. 3ARG works Mexican 9A and ITO in Nicaragua, both stations report traffic. 3AVJ is on again with 2 50 watters on 80 and one 50 watter on 40. All new antenna system and set for winter. 3BCZ is now Champ. Rag Chewer with 2ADH for 4½ hours with intermission for cats. 3BFG reports traffic. 3BGN works NEM. He handled traffic from the Radio show blew his 203A and now works old 203. 3BHM works 6th dist. and French 2DY nightly and 9CAN afternoons. He reports that 3AST, a new ham, will soon be on. 3BLP is on low power, working 3BRD, 3BJH, 3MU, regularly. 3BQK is on 40 and 80 meters and handles traffic. 3CCR worked 38YOR. 3CDB worked 4EJ. 3CNT is having transmitter trouble but managed to get a few messages going. 3CNX has a good traffic total. 3CVJ got to the coast with R9 reception and traffic, you bet. 3CYB is rebuilding the transmitter. 3DDL has schedules with 32BOW each Sat. night at 10:00 P. M. 3CHX works west coast, Florida, Alabama with a 201A on 80 meters. 3DME has BC station license now, WKBR. 3AHC is the op. 3DNE handled traffic from F. E. Handy to SCM at Omaha. 3DRJ works Europe—is now remodeling his station. 3DKN is now a line-man. We wish him pleasant weather. 3DSI says the Buffalo Convention broke him but is all paid up

now. 3HJ reports traffic as usual. 3NT handled Florida relief traffic. 3UL handles traffic as usual, although sight. 3VW has a new set on 80 meters using 2 H tubes in tuned grid and plate self-rectified circuit.

Traffic: 3ABG 5, 3ADE 44, 3AHC 26, 3AIL 19, 3AKC 77, 3AKS 9, 3ANK 23, 3ARG 13, 3AVJ 6, 3BCZ 36, 3BFG 12, 3BGN 54, 3BHM 68, 3BLP 6, 3BQK 34, 3CCR 16, 3CDB 6, 3CNT 8, 3CNK 576, 3CVJ 61, 3CYB 30, 3DDL 45, 3DEX 26, 3DME 32, 3DNE 324, 3DRJ 21, 3DSI 50, 3HJ 18, 3NT 27, 3PJ 6, 3UL 9, 3VW 9.

WESTERN PENNSYLVANIA—SCM. G. L. Crossley, 3XE—The reporting this month is a little better than it has been for some time, altho even at that, it is not as good as it can be. More stations are reporting but their reports are very light. This section suffered very badly, in the last month due to the Northern Lights and at times, no stations were heard all evening long. New ORS certificates have been mailed by the SCM to all ORS in the section and if you have not received yours, communicate with the SCM without delay.

3AXM and 3DOQ are in Florida. 3DLI, 3BRM, 3AWR and 3BBL will be on regularly very soon. 3BRB is still on the Great Lakes working commercial—he will be on the air about Dec. 15. 3AGQ is rebuilding his receiver. 3DKS is having receiver trouble. 3DEW is having power-leak trouble. 3BVK and 3DGL mourn the loss of their filaments. 3AGO and 3CWT are doing some good DX. 3CKP is reaching out on 80 meters. 3FM now has his set on 40. 3BDJ has been doing the act of hunting power leaks for BCLs—getting a standing. 3BW has just remodeled. 3ASB and 3CKM are now on the air with one quart bottle, 250 watts. 3CRK says he can't find any traffic. Come on, you outside sections, Western Pa. craves traffic! 3DNO is having Hertz and tube trouble (in a side note, he adds that a "blond YL keeps him busy"). Hi. He took a message from 3AKW at Philly and had an answer back in 10 minutes. It took 12 minutes from the time of filing till the answer was back. Western Union, please take notice! 3CDG, a portable set at the Pittsburgh Radio Show, handled messages free. QRM prevented them being sent to any great distance but 3AJU relayed them for the show on schedule. 3BGB worked 4UY with a 210 tube set in the 80 band. 3JW is an operator at Swathmore. 3VE has Medical school QRM. 3GK has a new 50-watt set chemically rectified and filtered. 3ARC is installing a sync. 3DNF is installing a crystal-controlled set. 3XE is on the air with a couple of ether busters, and 19 operators to do the busting.

Our Director, E. C. Woodruff, Communications Manager F. E. Handy and SCM, G. L. Crossley were present at a hamfest given Oct. 20 at Oakmont by the Oakmont Radio Club. It was quite a hamfest and the ham spirit prevailed. A good time was had by all and last, but not least, the eats. The SCM wishes to say that a hamfest is a fine thing and it is a fine way to get acquainted. Always go to a hamfest if you can possibly get there.

Traffic: 3AJU 106, 3AGO 102, 3CWT 92, 3GI 61, 3ASB 20, 3VE 17, 3ABW 15, 3SF 15, 3GK 12, 3DHW 8, 3CEO 8, 3CWB 7, 3ARC 6, 3CYP 4, 3BDJ 4, 3AXD 3, 3DOQ 2.

SOUTHERN NEW JERSEY—SCM. H. W. Densham, 3EH—Cold weather sure does get the radio bug going after the traffic hounds in fine shape. All you fellows who say you cannot find any traffic to handle take a look at what the live wire ORS in your district has done this past month. 3CFG, a brand new ORS, comes thru with a good total and cops the honors for the month. This total was rolled up with a 201A with the plate fed from an old spark coil. Power has just been installed in his shack and a larger set is now being installed so watch him in November. 3XAN has been doing consistent work at his home station. 3BLZ, on both 40 and 80. 3BMZ reports old 3BHQ back on the air with a new fifty watt outfit. 3KJ is going to night school but manages to get on the air occasionally. 3UT has been busting through to Europe. It must be his new Kenotron rectifier. We have missed 3ZP's signals of late but he will soon be back on the job on 40 and 80 meters. Are you all wondering what happened to the old 500 mile consistent rock crusher that signs 3BEI? The secret is that Walter is in the engineering department of the Victor gang and is working ten days a week testing

RCA supers. The talking machine companies seem to know where to go for good radio men. The Victor has gathered in a bunch of local hams including 3IQ and our old friend Patterson of the Ledger Staff.

Traffic: 8CFG 59, 8BMG 14, 8UT 10, 8KJ 6, 8BWJ 5, 8BEI 2.

### CENTRAL DIVISION

**K**ENTUCKY—SCM, D. A. Downard, 9ARU—Things seem to have livened up some this month. Keep it up, gang! Some of the fellows are on the air consistently, handling traffic and making regular reports to their SCM and still are not ORS. Let your SCM hear from you regarding your appointment as ORS. 9MN has been appointed Official Broadcast Station. He is also up at WLAP so maybe A.R.R.L. news can be broadcast via voice from that station. 9ALM says the town officials are trying to make a hundred-dollar assessment on all transmitters. Put the transmitter in Nicholasville, Om, and make it remote control. Hi! 9EP says he is working everything with a fifty watt and Escog now. 9ABR's traffic dropped off on account of sickness. Here's hoping everything is OK now, OM. 9BWJ, ex-8DOV, is a new station at Paintsville. 9ELL, 9OX, 9DK and 9ARU had a great time at the 9BUG-9TG hamfest at Jasper, Indiana. Don't forget to mail your Form 1 cards on the night of the 25th, fellows!

Traffic: 9OX 56, 9CRJ 33, 9CJW 32, 9ARU 27, 9MN 17, 9ABR 10, 9DTT 3, 9BWJ 1.

**I**LLINOIS—SCM, W. E. Schweitzer, 9AAW—Traffic this month has been extremely heavy due to the messages taken in at the booth allotted amateurs free of charge through the courtesy of the Chicago Radio Show management. May we express our appreciation for this courtesy. 9BFF tops the list of stations in the BPL. 9AGG is keeping schedules with 9NV, 9DRH, 9BNK, 9AXX and 9BFF using one UX-210. 9CIA spends the time pushing traffic out rather than putting amps into the antenna. 9DXZ is keeping schedules with 8CEP, Tuesday and Thursday at 8 pm, CST. 9CSB is keeping many schedules and uses a 20A. 9IX is again pushing traffic after his reconciliation with the ARRL affected by Beekley. 9DYD's old 7½ watt is perking so good that he is planning to put in a 50. 9APY is keeping schedules with 5ANL, 9BKJ and 9ASL. 9DXG reports more traffic on the 80 meter band than on the 40. 9UB-9FD is on the air every day from 4 PM to 6 PM using 50 watts most of the time. 9MT, and 9CHW are opening up at La-Salle, Ill. 9NV keeps schedules with 9AGG. They'd like to know how to hook a rope back up through the pulley of the 80 foot steel pipe mast without using sky hooks. 9QD using 50 watts on 80 meters, is going to try and make the BPL next month. 9DOX is on consistently. 9CXC using a 20A, worked O-A3B through 9ADG who did his receiving. 9AFB using a 210 on a Hertz antenna, worked all districts and Canada. 9BTX is a new ham just opening up, using a 210. 9MI is being operated by 9PU and 9AOA who are operating there while at the U. of I. 9AAE is supplying his high voltage from a dynamotor. 9CSL moved about 25 feet so he had to put up a new antenna. 9BBA is contemplating more power. Better DX on the Hertz, he says. 9AAW is still burning out 200 volt generators. Two in two months is two too much. 9RK is looking for some schedules. He is putting in a Mercury arc rectifier. 9ALJ will have 100 watts soon. 9BVP reports the Hertz FB on 40 meters. 9AJM worked South Africa twice, Australia, Cuba, Canada and all U. S. districts. 9DZR gets the official broadcast messages out regularly. 9AFF has been off the air most of the month. 9ELR is going to try a Zeppelin type antenna. 9BPX is all set for some real work this winter. 9ARM is not doing much at the present time. 9BRE is now out on the west coast operating 6CKG. 9DDE hasn't his new transmitter built as yet. 9DQR is moving back home so will be on the air shortly. 9AYB is at the U. of Illinois until Christmas. 9CYN, using a 5 watt, is working all over the USA and promises a great traffic report next month. 9CMX is a new ham and will be on with a 7½ watt soon. 9BRX reports not much doing at the present time. 9CEC has his station working on 40 meters. 9SK is using 15 watts supplied with 650 volts and is looking for so-called foreign DX. 9AMA is a new ham on 40 meters. 9DGA is keeping schedules with

9BOX. 9RQ is being operated by the second operator at the present time. 9ALK worked CH8AN. 9BHM still gets the report R6.

Traffic: 9BFF 502, 9AGG 190, 9DXZ 160, 9CSB 11, 9CIA 108, 9IX 103, 9DYD 79, 9APY 61, 9DXG 61, 9UB 56, 9NV 48, 9AAW 43, 9QD 38, 9DGA 37, 9DOX 36, 9CXC 31, 9RK 31, 9AFB 30, 9BTX 28, 9MI 27, 9CSW 26, 9AAE 22, 9CSL 21, 9BHN 21, 9BBA 21, 9ELR 14, 9CYN 14, 9AOJ 11, 9ALK 10, 9BVP 9, 9AJM 8, 9DZR 8, 9RQ 6, 9AFF 5.

**M**ICHIGAN—SCM, C. E. Darr, 8ZZ—8BNC and 8AUB, roommates at Mich. State College, are breaking the ether with a 5-watt. Of course, this is all between classes. Hi. A Hertz antenna helps do the dirty work. 8AUB wants a schedule with Detroit preferably on 80 meters. He has lots of traffic for Detroit. 8DDS of Battle Creek has a schedule with 8AUB of Grand Rapids. 8AUC has two operators and has almost continuous watch. 8CQG is looking for schedules. He is trying to keep Kalamazoo active in radio. 8DED was on the air 4 days and worked a 3EN. FB, OM. 8CEP is installing mercury arc rectifier, until then page the Buzz Saw. 8CWK, 8WO and 8ZZ are installing crystal-control transmitters.

The A. R. R. L. members had a booth at the Detroit Radio Show and had a transmitter working on 80 and 40 meters. It used battery, plate and filament supply and did good work, many messages were handled and great interest was shown by the BCL folks. Thirty-one subscriptions to QST were taken in and all were kept busy explaining the A.R.R.L. activities and purpose. We feel that it was an excellent idea.

On Sunday, Oct. 24th, the hams of northern Ohio and Michigan held their second get-together meeting at Monroe, Mich. over 50 hams attending and all voted for a return date. Another meeting will be held in January. Every ham that can come is invited.

The Detroit gang is getting QRV for the Michigan State Convention. We hope to have the best convention ever held in Michigan. If so, it will and must be a wiz.

MAKE schedules—it's the only way to handle traffic in a reliable way.

Traffic: 8CEP 47, 8CE 9, 8DED 5, 8CQG 50, 8ACU 27, 8DDS 7, 8AUB 83, 8DAG 11, 8ZZ 15.

**W**ISCONSIN—SCM, C. N. Crapo, 9VD—9DTK leads this month with a large total, some of which were tourists and Radio Show messages. Due to a change in schedule, 9DTK has discontinued sending market reports to WLBL. 9EK-XH has a crystal-control transmitter operating on 20.6 meters daily from eleven to twelve noon and all Sunday afternoon. 9AZN gets but very little time to operate because of the increase of the BCL business. He says that the Aurora Borealis put several of the lines out of commission in the vicinity and that DX has been poor ever since. 9BWO is still cutting hair as usual and says that he would rather trim the YLs than the OMs 9AFZ sent in a large total for his station, due to schedules with NAJ and the Radio exposition. 9BIB is still operating crystal control on 79 meters and has schedules with 9DTK and 9BKV. 9CDT operates occasionally on 40 and 80 when not busy at evening school. 9EHM says traffic is rather slow on 40 but expects it to pick up with better weather. 9EGW says he expects to be on the air regularly from now on. 9VD has put up a new 40-meter vertical Hertz which he is trying to get into operation. 9DLD sends in a very interesting report and includes items of interest from stations 9BPQ, 9DCP, 9EJM, 9DUJ, 9DCX and 9BQQ. The SCM wishes these stations would report direct once in a while.

Traffic: 9DTK 199, 9EK-XH 185, 9AZN 47, 9BWO 40, 9AFZ 38, 9DLD 32, 9BIB 22, 9CDT 11, 9EHM 8, 9EGW 4, 9EEM 2.

**I**NDIANA—SCM, D. J. Angus, 9CYQ—9BBJ is only on occasionally due to going to Purdue. 9ABP repairs BCL sets besides operating his own set. 9CNC is building a tuned plate-tuned grid outfit for 20, 40 and 80 meters. 9BRH is still on but QRM from work hinders the traffic-handling. 9AMI just finished a new chemical rectifier and gets much better results. 9BKJ reports good work beyond 500 miles on 80 meters but QRZ nearby. 9DRS was QSO NEVD 150 miles off the coast of China. 9DDZ is changing over from 10 watts to 50 watts. 9AEB reports more traffic coming his way than formerly. 9CMJ uses a brute force filter now and gets DC. 9BCM is rebuilding for 20 meters.



9RS changed from kenotrons to chemical rectifier with much better results. 9EGE is going now with a Hertz antenna and 7½ watts on 40 meters. 9CYW is using a Hertz antenna now. 9CMQ has trouble with sparks in the base of his 50 watter so doesn't dare run it. 9EJU is on now with his complete new transmitter and receiver working on 40 and 80 meters. 9TG put in a 250 watter on 80 and expects to set our phones on fire. 9AIN has a new 1500 volt generator and a 50 watter so will soon be splitting the air. 9ABW is ready to go as soon as he gets his plate supply. 9AYO has his 7½ watter ordered and will soon be on 80. 9DHJ uses crystal control and a Hertz. 9DLJ complains of a funny 500 cycle note in his generator, but gets out good. 9EF is just getting on the air with a 5 watter. 9BSK blew his 7½ watter and put in a 201A. 9CP gets out good on 40 and 80. 9BJR is back on the air with a 50 watter. 9CUD has completed his outfit, 50 watter and 1500 volt MG set. 9BYF just put in a new 50 watter and 1500 volt dynamotor. 9ASJ wants plenty of traffic for anywhere on earth as he is competing for the Indianapolis Radio Club traffic trophy (a 50 watter). 9ARK moved again and is on with 40 meters, 50 watter and 1500 volts.

Traffic: 9DPJ 6, 9TG 14, 9EJU 4, 9ABP 20, 9BCM 8, 9CMJ 20, 9AEB 18, 9DDZ 5, 9DRS 1, 9BKJ 71, 9QR 4, 9BYI 4, 9AMI 5, 9BRG 7, 9CNC 34, 9ABP 20, 9DZU 16, 9BJR 15, 9DHJ 19, 9BSK 19, 9CP 8, 9EGE 3, 9CMQ 5, 9ASJ 65, 9CRV 23, 9EJI 32, 9DSC 14, 9ACR 10, 9CLO 8, 9AQU 3.

OHIO—SCM, H. C. Storck, SBYN—Attention, gang! Here's 8BAH, not (at present) an ORS, who headlines the Ohio gang this time. FB, OM. But what's the matter with the rest of you? Perk up and let's go. 8DBM comes second. Atta boy, OM. SCMB is third, but would have had more messages if his H tube had not kicked the bucket. 8DEX says he is the only southpaw operator in the 8th district. (No you're not, OM, there's at least one other and that is the SCM himself. Hi). 8DMX turns in a nice total and is on much. 8BKM says schedules are the berries to get traffic and begs for more hams on the higher waves for this work. 8CQA is a new ORS. 8AKO pounds day and night, at 8HB and 8AKO. 8PL got a new sync and says he is working everything on the map. 8DSY reports fine DX and traffic work with a UX210. 8BF blew his big fire bottle. Tough luck, OM. 8GZ is QRW with school and YLs. He also bought a Lizzie and now 8GZ has gone by the board. 8ANM hopes to be on 20 meters every Sunday PM. 8CAU is back on the air again. 8AVB is going to make a good ORS pretty soon if he keeps up the good work. 8ADA is handling press with 8CZS. 8ALW is again with us and glad of it. Welcome, OM. 8AEU is QRW night school, but on the air, nevertheless. 8DPN is QRW YLs but says to watch his smoke this winter. 8EQ had tough luck and blew 3/50 watt tubes. 8CLR was heard in Australia so is all elated. 8CPQ is too modest. He tells about everyone but himself. Unusual. HI. 8ARS will be on the air with 14 ops soon. 8BRU is using pipe antenna and says its FB for steadiness. 8DIA is QRW school. 8DRX is sure unlucky. Can't work a soul and is going to rebuild. Good luck with new set, OM. 8SI is using a 201A and getting out FB. 8ADE is making a new panel type transmitter. 8AVX is on with a 50 now. 8BSC is getting along fine with two H tubes. 8DQZ can't make a Hertz work. Bad location. Let's help him, OMs. 8ADH is QRW school but is on the air some. 8AWX's work keeps him from radio a good deal but he makes good use of his spare time. 8DEM is another ham who is QRW school and only operating week-ends. It's tough on traffic. 8BCE is out of town a good deal, but thinks the next months will be better. 8AZU is the original tough luck baby. He broke his leg playing football and then his 50 went west. That is tough luck, OM, and the SCM wishes he could help you some way. 8DKW is away at school and will be irregular during the rest of the school year. 8RY is still at 2EP. Schenectady, N. Y. and wants QSO's from Ohio Stations. He's homesick, OMs. Let's listen for him. 8DHS says his business is interfering with his radio, so will have to cut out his business. HI, OM. That's sure ham spirit.

J. P. Turner, 8AU, of Cleveland has been appointed Route Manager for Ohio and is already hard at work. He merits hearty cooperation from all Ohio Stations. We are trying to make a net work of routes all over the US. The Route Managers of the various states are in charge. So, if you want to be a real traffic handling, schedule station and can promise faithful

work, write 8AU, giving data as to QRH, ability to QSY, operating hours, etc, as well as present schedules kept. Make your own schedules if possible and let the P M know. He will also assign schedules within your operating hours where it is necessary. Let's go, gang, and get on an efficient message handling basis. You'll enjoy the snap of it. 8AEU, 8ADA, 8BJ, 8BKM and 8DMX are the schedule operating stations this month and all are hearty in their praise.

And now, fellows, the time for dallying is over. Within a short time, every ORS who has reported to the SCM so far will get a new certificate. Lot's of them will be on probation. If you don't get one, you will know your former certificate has automatically been cancelled on account of not reporting. The dead wood will be weeded out, and we are going to have a live bunch here in Ohio. Anyone left out in the cold, may, upon a promise to do better, be reinstated. But the ORS in Ohio will have to be a LIVE bunch from now on, if they want to stay in. Miss two reports and you are automatically OUT. Miss frequently and you will be put on probation. An ORS certificate is not just a something to frame and forget but something to be proud of, and I mean to make it mean something to be proud of. So, you dead ones, better get a move on and redeem yourselves by writing soon and reporting.

SCBI of Columbus and 8APZ of Clayton have been appointed as Official Observers. There are at least two in every state who are appointed to take care of the off-wave hams. So, watch your step, OMs, and don't get caught. Of course, I know that none of the Ohio stations would be off-wave intentionally. HI. But help the fellows along, gang, or we may all be in the soup with the Navy Dept. soon. Hw?

Many more stations reported this month than last. That's FB and let's keep it up. A report is a report whether you handled any traffic or not. I want more live ORS also, so let's hear from you fellows who think you can qualify.

Traffic: 8BAH 254, 8DBM 148, 8CMB 88, 8DMX 78, 8BKM 70, 8CQA 52, 8AKO 44, 8PL 42, 8DSY 40, 8BF 35, 8DQZ 34, 8GX 27, 8ANM 26, 8CAU 23, 8BJ 23, 8AVB 19, 8ADA 15, 8ALW 14, 8AEU 14, 8DPN 14, 8ANB 12, 8EQ 12, 8CLR 10, 8CPQ 14, 8ARS 9, 8BRU 9, 8DIA 7, 8DRX 6, 8SI 5, 8AVX 4, 8BSC 4, 8DQZ 2, 8AHH 3, 8ADH 1, 8AWX 1, 8DPG 1, 8DEM 1.

## DAKOTA DIVISION

SOUTHERN MINNESOTA—SCM, C. L. Barker, 9EGU—(pro tem) 9DH had to quit the air on account of school and regular work. 9EFK is high man with traffic this month. 9CAJ now has his new chemical rectifier perking, and gets out much better, as his traffic figures will partly show 9IG now has a new station under call of 9NF, with two operators. 9DBW had the honor of handling 6AM's message number 1. We all recognize 6AM as being Don Wallace, ex 9ZT. DBW is after a mercury arc rectifier tube and has panel-mounted his whole set. 9BYA, a new Official Relay Station, has increased power to a 50-watt tube and reports another new ham in Minneapolis. 9AIR has designed a new antenna for 80-meter work and has his set arranged so he can work from under the bed covers these cool mornings. 9BKX uses a 201-A battery set temporarily until he finishes the rebuilding on the regular set. 9COS had a UV-208A on the job until 5 minutes before writing this report. HI. 9DHP keeps schedules with 9CDE and 6AIO. 9BHZ complains of not being able to get out, but the SCM hears lots of stations calling him every once in a while. 9SF put up a 63-foot pole and is going full-blast. Has arranged his set so he can use two 50 watters if necessary. 9BTZ started to sell Red's and expects to move to Rochester to run a branch. He keeps schedules with 9BAY.

Traffic: 9EFK 116, 9CAJ 91, 9IG-NF 46, 9DBW 19, 9BYA 18, 9AIR 18, 9BKX 6, 9COS 6, 9DHP 4, 9BHZ 3, 9SF 2, 9DEQ 2, 9BTZ 1.

NORTHERN MINNESOTA—SCM, C. L. Barker, 9EGU—The Northern Section is getting well organized now, since the SCM has been officially elected and under the able management of 9CPO, Schenectady, at Brooten, who is the new R-M, things are looking more favorable for traffic handling in this part of the state. Schedules are being kept and as a result, the



traffic figures are a bit different from months gone by.

9EHO is on using 150 volts of B battery, still waiting for the balance of the shipment that has been on the way for six weeks. 9CPO, the R-M, lost his 50-watter but has a new H-tube on the way. 9ASW hasn't a great deal of time to operate but is on whenever he can be. 9EGU keeps schedules with 44DW and provides a fine outlet for Canadian traffic. Schedules are being arranged with Duluth stations as well as some distant points. EGU will be crystal controlled just as soon as 9ALD gets the crystals from England and the wave will be very close to 37.5 meters. 9APF is getting started for fall and winter work, with a remote controlled set. 9MF reports two new amateurs in St. Cloud. FB. 9DUV has changed to tuned plate-tuned grid circuit in an attempt to steady his wave—he is using break-in and a Hertz antenna. 9BMX is shifting to crystal and as soon as he gets the quartz, will be steady. 9CWA now has a DC generator and keeps schedules with 9BBT and 9CTW. 9DKR is arranging three schedules and is all set for steady work. 9KV now uses a 50-watt tube and is another station turning to crystal control. 9CTW keeps schedules with 9CWA and uses a 7.5 watter with generator on the 40-meter band. 9ADF has now resumed regular activity and is doing much to pep up the Duluth gang. 9EEP affords a good outlet for North Dakota traffic, having schedules in that direction. 9CWN gets a big kick out of his DC note.

Traffic: 9CWN 46, 9EGU 26, 9EEP 18, 9ADF 18, 9CTW 15, 9DKR 12, 9KV 14, 9CWA 11, 9BMX 11, 9DUV 8, 9MF 8.

**SOUTH DAKOTA—SCM, F. J. Beck, 9BDW—**9DWN keeps several schedules in addition to college work. He turned in a fine total. 9ALN does both good DX and traffic work. 9DZI worked P. I. with his 7½ watter. 9DBZ—9CKD and 9DB-9BDW have changed from fundamental to 3rd harmonic operation with good DX and less local QRM. 9CNK increased power to 7½ watts and has skeds with 6th district on 80 meters. 9CJS is using fone on 80 and 175 meters. 9DIY is doing good work when the line voltage is high enough to run his m. g. 9DNS and 9DES are relaying messages for the Radio Show with 9AJP in the YMCA Radio Club booth. 9BBF is installing a xtal outfit for 20, 40 and 80, similar to the General Radio set with a 50 for amplifier. He printed the "S. D. QRM" and put out a fine edition. 9TI is installing his set in the living room as the cellar was too damp. 9AGL is back from South America running KUSD and operating an H tube. 9BRI got seasick but is going to stay at the commercial game a year. 9NM has a new receiver which brings foreigners in. 9DKL has a set going at Wessington Springs on 30 meters. 9CKF is doing fine DX with a UX-210.

Traffic: 9DWN 190, 9ALN 71, 9DZI 30, 9DBZ 12, 9BDW 12, 9BBF 6, 9CJS 4, 9DIY 3.

#### DELTA DIVISION

**MISSISSIPPI—SCM, J. W. Gullett, 5AKP—5FQ** has two new Signal Corps 50 watters on in a self-rectifying circuit in the 40 meter band. 5AGS has two H-tubes in a self rectifying circuit in the 40-meter band and says they work FB. 5API has a new motor-generator and two 50 watters on the 40-meter band and has a schedule with 9C every Sunday afternoon. He works all U. S. Districts consistently now. 5ANP has a 201-A on the 80-meter band using 110 volts of B-battery for plate supply. 5AQU has worked BG-1 using one H-tube but his transmitter has gone Democrat again and quit. 5AKP has been having considerable trouble with his receiver but finally located the trouble in audio transformer which was shot. The SCM has another application for ORS but is holding him off until he can give him a thorough trial.

Traffic: 5API 50, 5AKP 35, 5AQU 15, 5QZ 11, 5ANP 8, 5AGS 3.

**LOUISIANA—SCM, C. A. Freitag, 5UK—**The Radio Show opened with a very large crowd. A great deal of interest was shown in the ARRL booth where the transmitter of 5NJ was in operation handling messages. The location is on the fourth floor of a newspaper building, with QRM from elevators, and printing presses. We are pushing the messages along, nevertheless.

The Caddo Radio Club of Shreveport has installed a broadcasting station KRAC. The clubhouse has wired for electric lights, stoves and power by 5WY. The club has received a great deal of assistance from some of the big men of Shreveport. Sufficient apparatus to build the broadcast set was donated by 5AKI.

After a two year lay-off, 5BB has returned to the fold and is now using 2 UX210 tubes on 80 meters. Four of the old hams announce that it is their intention to get back in the game. They are 5BK, 5ABH, 5RH and 5HO. All of these boys are New Orleans hams and have been out of the game for some time, the YLs having attracted their entire attention. Hi. 5NJ is rebuilding and will be back on the air again within a short time.

Traffic: 5ANC 15, 5UK 14, 5ML 12, 5QJ 7, 5KC 5, 5WY 4.

**TENNESSEE—SCM, L. K. Rush, 4KM—**The SCM would like to have several reports on the activities of stations in eastern and middle Tennessee. You fellows around Chattanooga send in your reports. 4HL says that 8AEK visited the Mfs gang and looked over his junk. 4FA uses a 7½ watter and worked Australia two mornings in succession. 4CU decided not to ship out as a commercial op. 4BU has moved to 1660 S. Wellington, Mfgs. Tenn. He on the air shortly. 4DK reports that he is moving and handled traffic. 4KM is on the air every evening and finally got the 2000 volt MG going. 4IV must be dead.

Traffic: 4KM 30, 4FA 20, 4HL 13, 4DK 2.

#### HUDSON DIVISION

**NEW YORK CITY & LONG ISLAND—SCM, F. H. Mardon, 2CWR—**Now that the SCM has met all or MOST of the gang at the recent A.R.R.L. get-together and explained his views, guess we all understand each other better. Five Route Managers have been appointed for the five boroughs and they are as follows: Manhattan, 2EV, J. B. Kilpatrick, 206 W. 69th St., N. Y. C.; Bronx, M. Solotar, 2CYX, 1104 Clay Ave., Bronx; Brooklyn, David Talley, 2PF, 2222 Avenue O, Brooklyn; Queens, McKenna, 2AVB, 2805 8th Ave., Astoria, L. I.; Richmond, E. Roberts 2AFV, 7445 Amboy Rd., Tottenville, S. I. It is the request of the SCM that all hams get behind these men in their respective areas as they are trying to put over a big job—namely getting *inter-borough* traffic going.

Queens: 2HS has just put up a new 50-ft. mast and will be on the air in about a month with a 250 watter on 40 meters and a 15 watt fone CW and ICW on 176. 2BSL has a 50-watter with 80 watts input. 2CE wants the fact mentioned that he has two 50-watters going and is unable to handle any DX. 2AWQ is only on week-ends on account of college. 2AJE has rebuilt his set and is getting out FB, but not on much on account of school and football. 2CLG has changed his location to Hollis and will be on soon again if he can get his Hertz to work. 2AWX, the old standby at Lynbrook, has come up to 80 from 40 meters and says traffic is much better up there. 2AYJ got ptomaine poisoning from eating canned salmon and the first day out of bed, he blew more Kenetron tubes. He says he is going to put in a chem. rectifier. Hard luck all around, OM.

Brooklyn: 2APD is making a set of plug-in coils for his transmitter the same as his receiver. He says he worked 90% of all stations called Pretty good! 2CLA is very busy with his Division meetings and Army net. 2WG is working Xtal control on 38.9 and 42.07 meters. 2AVR is doing good work. 2CRB says DX is good now—he has worked 33 countries. 2CTY says DX is good but can't seem to pull much traffic thru. 2PF is very busy with his Army Net which is working very good now. 2BRB has had very bad conditions on 40 this month. 2BO has not been on much lately on account of Mrs. 2BO being sick in the hospital. Hope she is better by now, OM.

Manhattan: 2ANX is going ahead like a house afire. Keep it up, Om. 2CHK has just got back from Canada. He will be on the air regularly, soon. 2ALS has added a fifty to his two 210's but is having a hard job neutralizing it. 2LM is still on the job. 2CUQ has rejoined our ranks and promises to get in regular now. 2BNI and 2LD are still at it going strong. 2EV is having a hard battle trying to get his Army Net going. Get behind him, gang. 2BCB

went over the top this month and his second op is getting along nicely now—weighs 23 lbs. now.

Richmond: 2AKK is using a 201-A just now but will soon be on with a 210 if the necessary funds come to life. 2AKR is going strong and is one of the stations in S. I. for handling inter-borough traffic. 2AFV is going strong and is getting things in shape for the inter-borough relay route.

Bronx: 2ALL is keeping several schedules and going strong. 2AMJ reports DX has been great and he is getting his share, working about 20 foreigners every night. 2APV says things are going great at last and he is changing over to tuned plate and grid. 2OYX is rebuilding and is ready for a busy DX season, with four ops ready for traffic. 2BBX is certainly working all over the globe with that small set. He had a big tube in but the results obtained made him go back to the two 210's.

Now, don't forget, fellows, get behind your Route Managers—they are trying to really make the second district become known. Write your RM a letter and ask him what it's all about. More dope will be given on this next month.

Traffic: Queens: 2AWX 76, 2AYJ 56, 2CLG 28, 2AJE 22, 2CE 11, 2AWQ 7, 2BSL 6. Manhattan: 2ANX 133, 2BCB 122, 2OUQ 64, 2EV 43, 2BNL 26, 2CHK 18, 2ALS 18, 2LM 16, 2LD 8. Brooklyn: 2CLA 81, 2CRB 70, 2WC 25, 2PF 26, 2AYR 20, 2BO 17, 2APD 15, 2BRB 4, 2CTY 3. Bronx: 2COYX 154, 2BBX 91, 2APV 59, 2ALL 46, 2AMJ 20. Richmond: 2APV 64, 2AKR 45, 2AKK 14.

EASTERN NEW YORK—SCM, Earle Peacock, 2ADH—Heads Off! This report should be printed among the obituary notices. The following ORS have been cancelled for failure to report: 2ACS, 2ADM, 2AIF, 2AIL, 2AQR, 2AWF, 2BSB, 2BY, 2CGJ, 2CNP, 2COV, 2CPA, 2BM, 2COL and 2GK. This represents the threatened clean-up so that the Section is now composed of new ORS who are active brass pounders even though a number report nil every month.

Now that the funeral is over, break out the glad rags. 2AML made the RPL and turned his message file in for checking. This young squirt knows his eyes. 2QU is another station that is a credit to the Section and is probably the best op we have at present. 2ADH has a sked with 8BCZ starting as soon after midnight as possible and lasts until one goes under the table which is usually around sunrise. This pair claim the Rag Chewing Championship. Ask 8ADE about it. 2CNS bunches his hits. He doesn't operate so very often but when he does, he seems to pull a trick relay every time. 2ANV sends in lots of news with every report which is FB but the others up his way seem to think that it excuses them from reporting. 2CYM is on quite a bit but not as much as he would like. 2PV seems to be worrying about his traffic total. His new Heriz works FB. 2ANM has put in the tuned grid-plate circuit with a Zeppelin antenna. 2SZ, the Kentsdale Polytechnic station, sent a play-by-play report of the Kentsdale-Worcester game to 1AGA, the Worcester Polytechnic station. Thought 2AGM was through, but he turns up with a report to say his fifty is looking blue. 2LA stepped on a broken bottle and cut his foot, hence is off the air for a while. Hard luck, OM. 2AAZ is at college in N. Y. 2CTF uses remote control from the next room, because then he can't see his tube melting. Hi. 2DD is still plugging away but the more he tries the more trouble he runs into. 2AGQ is going to Cornell soon but will report just the same. More remote control??? 2CTH is worrying about his ORS certificate. 2BOW wants to go to sea. With an office full of SYTs like he has, he should stay home and develop his natural resources. 2ASE is going crazy working DX. 9ME has moved into the Section and is now 2EP at 108 Nott Terrace, Schenectady, N. Y. Welcome to the Second district, OM, the SCM wishes he had your call letters. Trade?

Traffic: 2AML 108, 2QU 86, 2ADH 62, 2CNS 13, 2ANV 20, 2CYM 8, 2PV 7, 2ANM 6, 2SZ 9, 2AGM 4, 2LA 2.

#### MIDWEST DIVISION

IOWA—SCM, L. R. Huber, 9DOA—I am forced to resign on account of studies at the State University of Iowa. In going out of office, I have circulated a petition for 9BKV as my successor, in view of the fact that he has shown, in my work with him, that he knows the business thoroughly, and has

the necessary station and time with which to do the work effectively. Had not such a man been available, 9DOA never would have resigned. As the case is, it would have been unfair to retain the office hand-capped both as to station and time. I hope that you fellows will give the new SCM your hearty support.

The axe has been used liberally of late, for it is my desire to turn over the Section to my successor without any laggard ORS in it. Perhaps those who have been the victims of the W. K. are now know that it means something to be the possessor of an ORS certificate in Iowa.

In going out of the ham game for the next indefinite several years, 9DOA wishes to extend to all fellows a hearty goodbye and a promise to CUL—sometime in the indefinite future (may it not be too long) when conditions permit. He has enjoyed working as SCM of this Section and he believes that he has made some improvements in it. He has always tried to work for the good of the A.K.R.L. and Iowa hams. Good luck to you all, OMs.

This month's report is marked by the effort of a few staunch brass pounders who know the value of a sked. 9BWN, a new ORS, tops the list and breaks into the RPL. 9CZC, Asst. R-M, follows a close second. 9BKV stepped on his tail and 9DAU came to life at last. 9AED and 9AXD still plug on and 9BPF, although busy at Ames and ILC, handled a few on week-ends.

Traffic: 9BWN 109, 9CZC 102, 9BKV 74, 9DAU 67, 9AED 25, 9AXD 23, 9BPF 11, 9CS 6.

KANSAS—SCM F. S. McKeever, 9DNG—Kansas had an unusually good DX month as well as a fair month for traffic. 9BGX has a new 50-watter on 40: 9BYQ works out well on phone and keeps several schedules. 9CLR and 9CVL now have commercials, the latter working at station KSAC. The Topeka gang are still at the top. 9CET, 9DPU, 9CV and 9AEK all were QSO Africa during the month. 9CET and 9AEK are trying hard to work Asia so they can get their WAC certificate. 9AEK and 9DNG are doing good work as Official Observers. 9KM only missed the RPL by one message this month.

9DFK is a new ORS and seems mighty promising. 9CKU reports working Nicaragua and handled some traffic. The Lawrence gang are pretty QRW at school. 9LN is on, nevertheless, and works Africa with ease. 9DNG worked a few Africans; also Educador, France, Japan, Morocco, and Australasia but was on little. 9AEY is hearing everything but reports no traffic. 9AVM and 9CKV are reaching out nicely and are QRW traffic.

Traffic: 9KM 99, 9DNG 28, 9CET 22, 9AEK 20, 9CV 20, 9LN 17, 9DPU 14, 9BHR 11, 9DFK 11, 9CKU 5, 9BYQ 4, 9CRV 4, 9AVM 4.

MISSOURI—SCM, L. B. Laizure, 9RR—The radio show station manned by the OBP hung up 277 messages, working the east coast on xtal 210 transmitter inside a steel building. 9AK was the station call. 9DMJ, 9BHI, 9BBK, 9DOE and 9PQ were the operators. 9RFQ furnished the transmitter which was adapted by 9AOT and installed by 9BEQ, 9DMJ, 9DLB and 9AOT using Burgess B batteries. The booth was furnished by the Post-Dispatch—QRM by the visitors—Scenario by 9ZK—Press notices by 9AOT. Nuff sed. ORS were issued to 9DUD and 9DOE. 9ZK closed down to rebuild the shack. 9AAL seems to be the only 80 meter station going. 9BEQ, 9DLB, 9DUD, 9DOE all report a good volume of traffic on 40 meters.

9DMT is the latest ORS addition, working on 80 meters. 9DWK reports working on 20 meters but no traffic. 9AOB was on only a few times. 9DVF handled a wad of messages, working on both 40 and 80 meters. A new ham, 9BVG, is reported by DVF as working on 180 meters phone in Hannibal. 9AYK reports QSR good on 80 meters. 9EAO returned from Europe with a French 200 watt bottle—also passed exam for 1st grade license. 9BSE kept schedule with 9DCD on 79 meters. 9CXU says school QRM kept him off the air most of the time. 9CDF moved to Stockton and started schedules with 9NW and 9ARA. 9ARA handles a big total and also worked O-A50 and Y-ICD. 9CVY worked UTY off Brazil. 9CWZ is recovering from an operation. 9BUE continued a schedule with 5ES daily at 6 P.M. 9BSH says there is quite a bit of activity around his town but no traffic. 9DKG reports a schedule in effect with 5AVB at Norman to QSR M. U-O. U. football game

scores. 5GG is at school at Kirksville. CDIX says they will combine sets. 9AYK has changed his OBS schedules on account of business QRM. 9AJW and 9UI are on in Fulton with the call 9BWR and keeps schedules with 9NW. 9AJW says he can't raise St. Louis but can work Australia OK.

Kansas City hams had a booth and station at the Radio Show. A good total of messages was reported. 9SS was used as a station call. There is little to report except that most of the gang were busy trying to get 9SS lined up and ready to handle business. The ham club gained a number of members thru the show activity and a good deal of publicity. The ham booth was a constant center of attraction to curious BCLs. Message activity is excellent on the whole tho a few fellows complain of outside stations declining to accept messages for relaying. Bum fists and rotten routing also come in for their usual panning. It might be well to mention right here that the ability to copy a bum fist is just that much more evidence that the receiving op is no lid himself—likewise, the knack of spotting errors in phony and mispelled addresses, etc. and correcting them before QRS of the message beyond your station.

Traffic: 9ZK 7, 9DOE 94, 9DUO 27, 9DLB 14, 9BEQ 75, 9AK 277, 9AOT 26, 9BWR 15, 9DKG 9, 9BUE 12, 9ARA 105, 9CDF 23, 9CXU 3, 9BSE 6, 9AYK 34, 9DVF 45, 9AOB 3, 9DMT 85, 9SS 180, 9ELT 200, 9ACX 104, 9ACA 120, 9RR 235.

NEBRASKA—SCM, C. B. Diehl, 9BYG—9DXY reports increased activities and several schedules. 9CJT is tinkering again and lets up on traffic for a change. 9EEW is busy with his railroad. 9AWS is working hard on a new antenna. 9DFR has a new receiver. 9EHW is making a new transmitter. 9BFG whoops it up again, as usual. 9BOQ is gradually getting into it, more and more. 9AEK is away at school. 9DPS is back in the collar. 9CGQ is tied up with his BCL station. 9DUO is rebuilding. 9DUH rested this month so didn't have much traffic. 9BBS has a rush and reports little traffic. 9AGD is hitting it strong again. 9BQR is back on 80 for winter traffic. 9ASD is a new ORS and QRW with army work. 9EBL is hitting hard with new plate transformer.

The Chief Route Manager asks for more traffic stations to take business from Iowa stations. Give him a hand! The Chief Observer says the Nebraska gang need no observer; they adhere strictly to laws and rules with regard to wavelenghts and hours. Allow me to congratulate the Nebraska gang—one more feather in our cap.

Cancellations of ORS certificates—With deep regret, we announce the resignation of 9CGS, whose work takes so much time he cannot give the ORS work the proper attention so resigned. When ready to resume, he is assured of another appointment. The SCM was forced to cancel appointment of 9DQC on account of his failure to report; also the appointment of 9NL who allowed his membership in the A.R.R.L. to expire; most of this on account of QRM from YL and flivver.

9ASD of Lincoln was recently appointed an ORS. We are expecting him to show up the rest of the Lincoln gang to demonstrate what an ORS is and can do. Mr. B. C. Burden of Red Cloud, Nebraska is QSO with either coast every night and requests that we hand him traffic. Please accommodate him.

9DXY has six schedules a week and is QRV for traffic. 9CJT is tinkering with a crystal. 9EEW is swamped at the office and hasn't time to radio but his report denies that. He doesn't QTK anyone. 9AWS has fun with a new antenna and a MA-PO. Here's luck, Bert, OM. 9DFR is rebuilding. 9EHW is also working on a MA-PO xmitter. 9BYG is still QRX with 9DR, where a 156-meter crystal is going in with m. g. feed and filtered sync for amplifiers. 9BFG is still at it with his pet Colpitts and WE 250. The crystal works OK but the amplifiers desire to oscillate as well. Hi. 9BOQ has a new 50-foot "stick" and is ably assisted by 9DTC. 9EAK is in Jersey City at school. 9DPS has a Hertz. 9CQG is QRX until Xmas, rebuilding. 9DUO is operating at KOIL. 9DUH is taking a "siesta". 9BBS is still QRW on his railroad. 9AGD has a new receiver. 9BQR had to go back to 80 on account of QRM on 40 from his tin roof. 9EBL is tearing the things up as assistant R-M for the western part of the state. He is mad because there is not more work to be done.

J. R. Willson, op on U.S.S. Sciota at Panama, has a fifty on 40 meters and asks us to report his sigs and QSO NEVK if possible. Full QRA is Balboa C. Z.

care U. S. S. Sciota. No regular hours account of assigned to duty in South American revolutions but he thinks he will be on after midnight E. S. T. several nights per week.

Traffic: 9DXY 62, 9CJT 1, 9EEW 41, 9AWS 4, 9DFR 34, 9BFG 72, 9BOQ 14, 9DUH 12, 9AGD 67, 9EBL 45.

## NEW ENGLAND DIVISION

MAINE—SCM, Fred Best, 1BIG—Things are about the same at 1BIG. 1AIT beat 1ATV by one message which leads us to believe that they had some race. 1AYJ had his usual good total in spite of illness in the family. 1BFZ fell just below the BPL this month. Watch his next time, fellows. 1HB has started up for the winter and is going great guns on the 80 meter band. He is good prospective BPL material. 1FP is all set for the traffic months ahead. 1EF is getting out well. He worked Porto Rico with a Ford spark coil supply. 1COM, a newcomer to our ranks, worked Belgian 4-ZZ with ease. We expect a great deal from him in the traffic line. 1BNL found time to handle a few. We sure miss the totals he used to turn in. 1AQL is away quite a lot, but finds time to clear a little traffic. 1CFO has decided to keep South Portland on the map. FB, OM! His very low power outfit gets out in great shape. 1ABV, also another newcomer, has started up in Skowhegan. Here's hoping he decides to become a traffic man rather than a DX hound!

Traffic: 1BIG 685, 1AIT 208, 1ATV 297, 1AYJ 181, 1BFZ 83, 1HB 26, 1FP 13, 1EF 13, 1COM 7, 1BNL 6, 1AQL 2, 1CFO 3.

RHODE ISLAND—SCM, D. R. Fancher, 1BVB—Traffic has picked up a lot in this state this month and it is due to schedules. It is the only way that traffic can be moved in any great amount.

Providence: 1AID carries the banner this month by being the first YL to make the BPL. She was off for a week due to a bum storage battery or her total would have been higher. She keeps schedules with five different stations and moves traffic in big gobs. Her sister, Lillian, is having too much OM QRM to pound brass. 1AWE says that besides working France, England, Brazil and all the states except Idaho and Nevada, DX is awful poor. Hi. 1AAU has a new receiver that works perfect. 1DF made a new ham receiver that turned out to be a fine BCL set. Hi. 1AHE is getting ready to change his QRA. 1AHT and 1BLE are both simmering along about the same. 1CKB and 1BDQ will soon be ORS in this section.

WESTERLY: 1AAP says traffic seems to be picking up on 40 but signals fade terribly after dark. (It is found to be the same at 1BVR). 1BVB has a better location and is getting out better than ever. Traffic has moved great as schedules are kept with 3 different stations with more to follow. 1BVB made the BPL this month, also. 1BLW has increased power so he can't be classed as a low-power station any more, altho he is using an inside antenna and counterpoise.

NEWPORT: 1BQD is set up at his new QRA and is just getting under way in good shape.

Traffic: 1AID 157, 1BVB 131, 1AAP 41, 1BDQ 14, 1BLW 7, 1AAU 6, 1AEI 5, 1CKB 4, 1AWE 2.

EASTERN MASSACHUSETTS—SCM, R. S. Briggs, 1BVL—About 26% of the ORS in this section are in the BPL this month. Very FB, gang! Let's keep up the good work and help put the New England Division, as well as our own Section on the map.

1BMS leads the BPL. He worked Austrian OHL and other foreign stations. 1UE, Route Manager, did some fine traffic work, having schedules with 1BIG, 1BMS, 1AHV, 1BFT and 8AKC. 1BVO has another call, 1NQ. He had a broken 50 watt regenerative receiver in the mail. 1BZQ has a trick super regenerative receiver but can't make his transmitter work on 40 meters. 1YC handled a bunch of traffic with 1WF at the Boston Radio Show and relayed a message to Governor Fuller at the Sesqui. 1ZW is QSO with all parts of Europe. 1AGS works 6's with a fiver and then wants a fifty. A perfectly good vertical antenna blew down at 1AHV's shack but nevertheless, he QSO'd NISS at Kiel, Germany. 1AYX is all ready for traffic and DX. 1OU is trying to hook up with GMD of the Roosevelt Expedition. 1CJR is QRW at MIT but hopes to pound brass at 1XM. 1BKV changed his QRA and does better now. The news comes from 1NK that he blew out a UX-210 seven times

but it is still going after seven successful operations. HI. INBV worked 9NV. Guess they are related. 1RF has been busy working French stations and Y ICD. 1BZ is rebuilding. 1RR has his Xtal set going at last on 89.5 meters. After getting up at 5 a.m. for a week, 1BCN finally worked an "Aussie". 1AXA is rebuilding his Xtal transmitter. 1LM is just getting started at his new QRA. 1AVY has a new motor-generator. 1ON reports that 1JA blew his H tube. 1BKE is waiting for Santa Claus to bring him a crystal; and 1AYG is stepping out with a couple of 201-A's. 1PB is a new station in Wakefield. 1ALP did a lot of traffic work on 80 meters. 1GA finally got his Xtal set going OK. 1KY is looking for more schedules. 1BHS is back again strong. 1BVL had a fierce time getting his Xtal control to behave. 1XM is QRV traffic with a 250 watt on 40 and 80 meters. 1ABA is combining with 1PL. 1SL used his portable set. 1WF, at Camp Devens.

Traffic: 1BMS 576, 1UE 261, 1BKV 219, 1BHS 207, 1AHV 154, 1YC 186, 1KY 129, 1ABA 120, 1ALP 111, 1NK 106, 1MR 100, 1BZ 70, 1SL 57, 1BZQ 48, 1JL 48, 1GA 34, 1NV 31, 1ON 27, 1ZW 22, 1CJR 20, 1BVL 16, 1AVY 14, 1AGS 11, 1RF 9, 1LM 8, 1OU 6, 1AWB 6, 1BCN 5, 1PB 5, 1AYX 3.

VERMONT—SCM, C. T. Kerr—1AJG—Only two stations reported and both were in Montpelier. Thanks, boys, for standing by me so well. And now, you other boys, please get busy and let's know what you are doing and going to do. 1BBJ, as in the past few times, is high man. 1BEB will soon even up though he has new 203A and an Esco 400 watt MG. That's the stuff, OM.

Traffic: 1BBJ 46, 1BEB 4.

CONNECTICUT—SCM, H. E. Nichols, 1BM—Activity in distance work throughout the state for the month is very commendable and the records are tip-top but your SCM would like to enlist the aid of every station in operating on the 80-meter band with the purpose in view of getting each one working with his nearest neighbor and establishing a dependable traffic lane from one end of the state to the other. Will you help out, OM?

1ADW qualifies for the Brass Pounders' League and deserves real praise. 1AOX reports that his power lines absorb too much of his out-going energy but he hopes to get the right combination soon. 1BDI, our hustling C. M., is keeping schedules with 1BIG and 2CXL so if you can connect with either, you will be able to reach the other. 1BHM, Route Manager, reports considerable activity for the New Haven Section and is planning to have his city on schedules for both time and definite wavelengths. This will result in greater cooperation and better handling of traffic. 1BEZ handled two messages from the Chicago Radio Show for England and put them across. 1CTI handled a message from the Abyssinian Expedition for Headquarters which starts him on the path to fame in our fascinating DX game. 1CKP seems to have the South American countries listening for him as he reports twenty-four Brazilians to date. Guess he must know Esperanto quite well by this time. 1IV reports his new transmitter nearly completed, also that he is now on the engineering staff of WCWS.

Traffic: 1ADW 117, 1AOX 77, 1BHM 28, 1BMG 25, 1BEZ 24, 1CTI 18, 1BDI 15, 1BJK 13, 1BGC 9, 1BLF 9, 1CKP 9, 1BQH 3, 1ACD 2.

WESTERN MASSACHUSETTS—SCM, A. H. Carr, 1DR-1AAC is almost ready to go on the air with his new transmitter. 1AAE wishes to think QST for the article on his station. 1AAL, our new R-M, has been busy with schedules and routes. He will have out a map and hours of operation of stations in Western Mass. very soon now. Thank you all for your cooperation in this matter. 1AJK handled an army message last month and is keeping some schedules. 1AJM surprised us all with a total that puts him in the BPL. This is certainly PB for a new ORS and should spur on the rest of us. 1AMZ says that college activities kept him off the key but he will be at it again week-ends soon now. 1AOF did some hunting in Maine and didn't say what luck. A broken-down generator kept him off the air. 1AUL is now rebuilt and promises a lot of action. 1ASU made the remarkable percentage of 77 in working Europeans. He says he called 13 stations across the pond this last month and worked 10 of 'em. He is using 3rd harmonic on 40 and working below the fundamental on 80. 1AWW nearly lost his head when his

eight foot mast blew down and wants to fight with a certain guy wire manufacturer. We may stage this bout at some ham function a little later. Watch for the date. 1AZW says he is going to make the BPL or bust but is spending part of his time in an orchestra. We may have music at the bout. 1BIV is doing good traffic work and wants more schedules and so does all Western Mass. Please write our Route Manager, R. L. Brown, 42 North Worcester Ave., Worcester, Mass. He'll tie you up with someone. It will increase your percentage and ours too. We have at last heard from the Worcester YMCA and we believe 1BKQ is alive again. Our old time friend and good traffic station, 1JV, is on again and wants to chat with all his ham friends. 1PY is handling messages for the Stutz Motor Car Co. FB, OM!

Traffic: 1AJM 130, 1AAC 9, 1AAE 46, 1AAL 24, 1AJK 11, 1AKZ 5, 1AMS 14, 1AOF 3, 1APL 8, 1AQM 4, 1ASU 22, 1AWW 13, 1AZW 62, 1BIV 46, 1BKQ 1, 1DBB 11, 1JV 11, 1PY 3.

NEW HAMPSHIRE—SCM, V. W. Hodge, 1ATJ—The gang sure did turn in an excellent report this month. We have three ORS in the BPL. Five ORS have been cancelled for failure to report. 1BFT-1OC has been appointed Route Manager. 1IP, a newcomer to our ranks, sent in a fine report. He will be an ORS soon. 1AOQ says he is going up on 150 and see what's doing. 1CKK and 1AOH are at college. 1AVL claims the YL has him cornered but managed to make the BPL. To show you how schedules help your total, 1BFT got 62%, and the SCM 96% of their traffic thru schedules. 75% of the messages were handled in the 80-meter band, 57% of the stations are on 40, 28% on 80 and the rest on both 40 and 80 meters.

1BFT-1OC, The R-M, is on 80 meters daily except Sunday from 5:45 to 8:00 PM and at 7:00 AM. He is on 40 whenever possible. 1BFT is used on 80 and 1OC on 40.

Traffic: 1ATJ 316, 1BFT 191, 1AVL 101, 1IP 55, 1AER 43, 1AOQ 38, 1JN 6.

#### NORTHWESTERN DIVISION

IDAHO—SCM, H. H. Fletcher, 7ST—That's better, gang. Looks as if the state were going to pep up a bit. The SCM would like a word from each fellow in Idaho, telling what he is doing as it is hard to get QSO. To stimulate interest in traffic-handling, The Boise High School Radio Club has offered a subscription to QST to the highest traffic man in Idaho for the month of November. 7JF leads in traffic tho he used a 201A. He is using a UX210. 7ABB is getting out good. 7YA has a 203A with four choices of power—3 M.G.'s and a 1300-volt bank of barts. 7ST is working when he has time. 7ZN on 40 worked pl, hu and m. 7GW is getting back on the air. 7QC is holding fort in the extreme north. 7KJ and 7ACE are at Lindley Hall, U. of I., Moscow Idaho. ORS are 7JF, 7GW, 7YA, 7ST and 7QC. All others are cancelled.

Traffic: 7JF 42, 7ABB 17, 7YA 5, 7ST 6.

MONTANA—SCM, A. E. Wilson, 7NT—7PU took in the Tacoma Convention and reports a great time. He also did his usual stuff with traffic. 7PU is the Route Manager for Montana. Shoot him your regular schedules, fellows, so he can make up a route list for our Montana sevens. 7AAT is a new ORS at Red Lodge, Orville W. Viers. He handled 'em FB for a newcomer. He worked 133 U. S. stations and promises to handle over a hundred next month. More power to you, OM. 7DD had tough QRM conditions from local power lines. Best DX on 80 meters but some on 21. Carl F. Wilson is on the air at Bonner, Montana. He is asking for ORS and promises to fill the qualifications. 7NT took a 300 mile trip in the Ford over the State this month and didn't handle any traffic. Saw some of the gang.

Traffic: 7PU 106, 7AAT 26, 7DD 11.

OREGON—SCM, A. C. Dixon, Jr., 7IT—It is encouraging to notice activity in other parts of the section than Portland. Heretofore Portland had been the only live ham center in the state but the rest of the gang are waking up. 7EO in Dayton has installed 80 meter phone. 7WB in Astoria promises a racket from his town in TEC. His own station worked out well. 7SY-PD cleared all traffic thru Eugene. In Portland, 7AV, 7IT, 7AEK, 7PP, 7JO and 7VP have been in the lime-light. The SCM wishes there were more reliable

stations like 7AV. He is too QRW to work very much, but all of his messages are delivered promptly. 7IT has handled 10,000 words of traffic with 2XA since last summer. 7AEK has installed a 204A, the first in Oregon. 7JO and 7VP have both jumped to fifty watts with good results.  
Traffic: 7AV 14, 7IT 10, 7WB 10, 7SY 9, 7PP2 7EO 1.

WASHINGTON—SCM, Otto Johnson, 7FD—Reports are starting to come thru on time now, due perhaps to the cancellation of some of the dead material in this section. The ORS tickets of eight stations were cancelled due to failure to report. It is hoped that the remainder of the stations take the hint and keep their reports coming thru on time.

7VL leads the traffic stations. His working hours have been changed, however, so he will not find so much time for radio. 7EK is warming up and will show, em all the way. 7AM is doing real good work on a 201A but says a 310 is coming up. 7UQ handles much Air Mail traffic on schedules. 7AG has a new 203A and works everything. 7QB is a new-comer but starts out right. 7RL is at WSC now and has worked all his DX over again from the new QRA. 7TX is coming on regular. 7OY hopes to have more time for radio soon. We all do, OM. 7GB is having key klick trouble. 7GE still keeps schedules with his M. D. 7AIM says no time for radio. Many of the hams at WSC will operate 7UL this winter. 7RL, 7BU and 7UU sent the returns of the WSC-U of W. football game from Seattle to Pullman via Wilkins Arctic transmitter, also thru KJR and KFOA via the key flick route. Hil 7QN at Seattle will be on soon. 7FD is working on his mercury arc rectifier. 7AW has come back on the air. The bunch are still recuperating from the effects of the Tacoma Convention. Spokane in 1927, fellows!

Traffic: 7VL 64, 7EK 50, 7AM 45, 7UQ 34, 7AG 15, 7QB 10, 7RL 6, 7TX 6, 7OY 4, 7EO 2.

#### PACIFIC DIVISION

SANTA CLARA VALLEY—SCM, F. J. Quement, 6NX—The axe fell this month and a good many former ORS of this section will no longer receive Handy's monthly bulletin. This Section will no longer tolerate stations unwilling to cooperate to the extent of dropping a card to their SCM each month. The Section was host to the Pacific Division Convention held in San Jose, on Oct. 15, 16 and 17th which proved to be the most successful convention ever held on the coast. 6AMM, with two complete transmitters, was the most consistent station this month, holding schedules with pi-1BD. 6BYY is organizing a USNR Radio Unit and would like to QSO all hams interested. 6BYH, a new ORS, handles 30 messages for a start. FB. 6CKV was QSO o-A50 and o-A3E up to 8:30 am. Also worked ARCX-SS Nilsen Alonso-Hobart from Balboa. 6BMW was QRW school most of the month but managed to QSO Africa several times. 6BCH with 20-30 watts raw AC input, is QSO Japan and East Coast quite frequently. 6CIS is moving to S. F. 6CUL, 6BTJ and 6CLP handled their usual amount of traffic. 6BNH is still operating his portable in high Sierras. 6ALW is ready for traffic now. 6CJD, 6HC, 6CEI, 6AJZ and 6MP were all QRW but hope to get going next month. 6NX, using current feed Horizontal Hertz 55 ft. high, reports better results than ordinary.

Traffic: 6AMM 52, 6BYY 41, 6BYH 30, 6CKV 29, 6BMW 21, 6BCH 20, 6CIS 11, 6CUL 7, 6BTJ 5, 6CLP 4, 6BNH 4, 6ALQ 3, 6NX 1.

SAN FRANCISCO—SCM, G. W. Lewis, 6EX—The gang hangs out on 40 meters with the exception of a few who use 20 on Sunday afternoon. 6RW, with one KW is QSO pi, a and o on schedule every morning. 6PW is running a close second. 6HJ is still QSO hu on schedule. 6CLS is QRV in spite of college. 6CCR and 6EX have reliable wavemeters and will act as O-O. 6VR is at Walnut Grove, Calif, convalescing. Drop him a line gang, care General Delivery. 6SZ, 6GG, 6GW, 6AON, 6BIA and 6EX are installing high power. Watch their smoke. 6UNC is QRD 5 meters.

Traffic: 6RW 225, 6PW 135, 6CLS 46, 6VR 39, 6CCR 65, 6EX 24, 6HJ 10.

ARIZONA—6ANO sent his report direct to HQ this month as he was not sure of where to send it.  
Traffic: 6ANO 303.

SECTION 6—St. Clair Adams, SCM, 6BAF—6BAF handled only a few messages during the past month. He has been on the air very little. 6AHL is a new ham in Eureka, with low power B battery set but he is working out good with it. 6BAF built his transmitter for him as 6AHL doesn't have much time.

PHILIPPINE SECTION (provisional)—The first report from his new section was received by radio via 9DKM: HR MSG FM CAMP NICHOLS P I 1BD NR 354 CT 3 CK 106  
TO ARRL HARTFORD

CONDITIONS IMPROVED HUNDRED PERCENT IN LAST TWO WEEKS STOP STATIONS WEST OF MISSISSIPPI ARE HEARD AS LATE AS NINE PM STOP NO TWO WAY COMMUNICATION ESTABLISHED EAST OF ROCKIES EXCEPT WITH A FEW FIFTH DISTRICT STATIONS STOP WHY DON'T USA AMATEURS LISTEN ON THEIR OWN BANDS OCCASIONALLY AS PHILIPPINE BANDS ARE SAME STOP COMMUNICATION POINTS WEST OF HERE EASILY ESTABLISHED STOP PI 1BD IS ON EVERY DAY FROM 0009 to 0014 AND 0019 to 0023 GMT ON 38 METERS STOP PI 1HR USES 39 METERS AND 1AU IS ON ABOUT 36 METERS—PI-1BD (NX).

Traffic: PI-1BD, 228.

LOS ANGELES SECTION—SCM, L. E. Smith, 6BUR—This month we attended the greatest Convention that the Pacific coast has seen both in attendance and quality, thanks to the escorts of a fellow SCM, Frank Quement in San Jose. Mr. Hebert was with us from Hartford and met the gang at the Convention, also at meetings in Los Angeles and San Diego. Some changes are about to take place in this Section so that the SCM asks that everyone possible attend all ARRL meetings and help with the work.

San Diego: Our old friend and one of our most faithful brasspounders, 6AJM, leads in traffic and schedules. 6CGG, the RM, is very active and doing good work, having obtained the convention for San Diego next year. 6BQ's job has kept him on the road this month so little work was done on the air. 6SB is playing football. If he is as fast as his sigs, he ought to be good. 6MB is using a 50 with a new MG. A crystal control outfit at 6BAS is sure doing good work. 6AKZ is active in all ARRL work.

Los Angeles: 6BBQ in Pasadena, sure hit the ball this month, leading the rest of the gang by several hundred messages. Old 9ZT, now 6AM, is on the air with a couple of watt burners. 6CLK, 6ALZ, 6BUR and 6CHZ from Whittier traveled north to the Convention. A good time was had by all, that is no flat tires or speed cops. 6AJI is now working in a bang in Long Beach. 6CAH will be on with another call soon—6CCD. Notice this—6BXD has kept nightly contact with ARCX, a whaler 600 miles south, every night for two weeks now. Good work. 6CSW is back with us from a trip to the 2nd Dist. 6GMV handled a message from the Smithsonian Inst. to FX1. A 1 K. W. outfit at 6CYH is promised soon. 6BHI has had three bad 50 watters in five weeks. Tough, OM. 6CGK is now working with a lazy fifty watter. Figure that out. So. Africa and Borneo are easy for 6AE with a UX210. Cal. Tech. teachers do their best to keep 6CMG too busy for radio but no luck yet. 6BTM was QSO O-1SR. 6DEG has built one of QST's long-wave receivers and says it is FB. 6IH is working good DX. 6BVO says South Africa is easy. 40 meters is getting old for 6NW so he is going back to 80. 6LH is doing fine work with a 7½ watter. 6CRZ is back now and pounding out. 6BBV didn't quit after all. FB. 6DAJ reports his UX210 as good as his 50. 6BGC has gone to sea on a private yacht and says he will have a short-wave set soon. 6DDO is doing good reliable work and is very active in ARRL affairs. 6BUX says that by using a storage batt. on his tube filament, he gets a much steadier note. School keeps 6CT rather busy. 6BH complains of trouble working east. 6BHR, a new prospective ORS, turns in a fine starter of 52 messages. 6NP's store is doing a rushing BCL business and keeping him off the air. 6AHP reports being QSO, AGE, QRD South Pole. 6AOY is on consistently and was seen at the convention. 6BJX spent most of the month traveling and so had little time on the air. College is keeping 6RF on the jump. YLs, I'll bet.—SCM. Several good schedules with US keep 6ZBJ's traffic up! Very good.

Fresno: The entire gang turned out to the convention and from what the SCM saw, they sure have plenty of pep. 6BAV, the RM, complains of power leak trouble. 6ALR continues his work on a 7½ watt. A tuned plate-grid circuit is being installed at 6CCL's.

Traffic: 6OR 27, 6AE 31, 6CMQ 2, 6BTM 21, 6DEG 9, 6IH 23, 6BVO 21, 6MB 19, 6AJM 27, 6CGC 5, 6LH 64, 6NW 9, 6BQ 4, 6BJX 64, 6CLK 29, 6ZBJ 72, 6AM 1, 6SB 14, 6AJI 47, 6BXD 72, 6CSW 17, 6CMT 16, 6BBQ 442, 6CYH 46, 6BHI 20, 6CGK 16, 6BAS 92, 6CRZ 10, 6CCL 18, 6BBV 15, 6BWS 58, 6BAV 6, 6ALR 35, 6AKZ 13, 6DAJ 12, 6BGC 15, 6DDO 53, 6BUX 19, 6CT 6, 6BH 21, 6BHR 52, 6NP 16, 6AOY 6.

NEVADA—SCM, C. B. Newcombe, 6UO—6GA is now an ORS and is moving a nice bunch of traffic. Several more ORS appointments are in sight in Reno. We want a good relay station in eastern Nevada.

Traffic: 6UO 33, 6GA 27.

### ROANOKE DIVISION

VIRGINIA—SCM, J. F. Wohlford, 3CA—3MK sends in a report working 40 meters and building a new receiver. 3GF installed a new outfit with tuned plate and grid and a 50-watt feeding a modified Hertz antenna. It's working PB but no traffic. 3CEB, 3AHL, 3KU, 3JF, 3UV, 3AJT and 3MK expect to do some real work this winter. 3CKA, who is very busy, reports no ham work but hopes to be on soon. 3BMM is still doing land office business at his radio shop. 3BGS says his gang is all busy at school. 3BZ hasn't much time for radio at present but he did work a station at Vienna, Australia. 3BDZ threatens to stick a big yelp in the air before long. 3BHS is staging a comeback on us. 3CKL seems to work about anything that he tries as he is very QRW playing Indian on a football squad.

Traffic: 3MK 12, 3BGS 9.

WEST VIRGINIA—SCM, C. S. Hoffman, Jr., 8BSU—New ORS certificates have been issued to 8BSU, 8SP, 8AYP, 8AMD, 8AUL, 8GDV, 8BUB, 8CEK, 8WZ, 8BJG, 8BBM, 8BNF, 8BXP, 8AWV, 8CYR, 8ALG, 8CRR and 8ACZ. These hams are RELIABLE and will QSR your traffic any time.

A-A traffic nets are again being organized.—8AMD-8SV being the net control station. Some good relay work has been done during the month by 8AUL who handled messages from the Norwegian Antarctic Expedition (GRD-1), VOQ and NEVK. 8CDV, 8CEK and 8BUB are very active making schedules. 8BSU and 8DUH are experimenting with low power. 8AYP is putting in a 1-kw. tube. He is in the BPL again this month. 8ACZ works with an 80-meter fone. 8SP says he was on the work! 8CYR will be on 40 with a 50-watt set.

Traffic: 8AYP 216, 8ACZ 58, 8BUB 17, 8CDV 15, 8AMD 9, 8DOH 6, 8AUL 4, 8BJG 5.

NORTH CAROLINA—SCM, R. S. Morris, 4JR—4PR passed his first grade exam OK. 4MI is now on with crystal control on 40.3 meters. 4TS had hard luck and became sick as soon as he got his set ready to go on the air. 4PP is going full force now and shows promise of being an ORS soon. 4WE has tube trouble. 4NJ is heard very seldom. 4RW is selling out—sorry to lose you, OM. 4NH is now using remote control with his crystal. 4BX passed extra first class amateur exam. The Charlotte gang are on every Sunday from 6 to 8 p.m. and QRV for all traffic,—delivery guaranteed in Charlotte. 4RY is back on the air at Davidson College and has applied for ORS. 4JR is doing a little work pending arrival of his crystal.

Traffic: 4MI 58, 4NH 28, 4RY 19, 4PP 14, 4JR 12, 4WE 11, 4BX 7, 4RW 6, 4NJ 5.

### ROCKY MOUNTAIN DIVISION

COLORADO—SCM, C. R. Stedman, 9CAA—Due to 9AMB, 9WO and 9EFY going away to college and being unable to be on the air, a few ORS certificates have been cancelled. One new appointment has been made—9DWZ. 9DKM is the new Route Manager for Colorado and is busy getting lined up on how things stand now. Other Route Managers are invited to communicate with him. Mr. Hebert, ARRL field man, spent an enjoyable two days in Denver, and

was the Headquarters' delegate from HQ to the ARRL Rocky Mountain Division Convention.

9DED has been on a little but at the present, his station is torn up. 9OO has been doing his stuff as usual. 9EAM is back in operating shape again on 80 and 40 meters. He promises a good report next time. 9CDW raises about everything he calls, and from what the SCM has heard over the air, it sure is the truth. He uses one UX-210. 9CJP has been trying to make an R.F. transmission line transmit and is having fair luck. 9DWZ worked 1500 miles with 20 watts input and soft tubes. 9QL is doing practically all of his work on 20 meters now. 9DLA is not an ORS as yet but reports just the same. The same applies to 9RQO. He is using a Hertz antenna and says it sure does do its stuff. 9CAA has two schedules working fine and another one in the immediate prospect. He is using remote control and is on 40, 80 and 200 meters. 9DKM has been playing around with aerials and built one like on the cover of QST recently. He says it is the best of all and is using it now. 9BJM has been sick but is OK now.

9BYC is the only station reporting from District 1 this time. He is experimenting with different aerials. He also has three schedules working and hopes to be in the Brass Pounders' League soon. A new station will soon be on in Fort. Morgan. 9CDE is still working everything in sight whenever he is able to get on the air. 9BYL is a new station in La Junta. 9DUI at Colo. Springs is feeling fine over hooking up with Nicaragua.

Traffic: 9CAA 106, 9DWZ 6, 9BYC 43, 9DKM 30, 9BQO 53, 9DLA 14, 9CJP 8, 9DUI 32, 9BJN 2, 9CDE 14, 9OO 16, 9EAM 20, 9QL 5, 9CDW 9.

UTAH-WYOMING—SCM, Art Johnson, 6ZT—The 80 meter stations operating in this part of the country are handling the least traffic. You fellows should have your transmitters calibrated for both waves in order that you may use either at any time. We should also like to see some 20 meter work in this territory.

6AIK, our newest ORS, is on 81.5 meters and has made a fair start. 6BTX is back on the job on 80 meters and has schedules with 3QL and 3ADE. 6BUH is reconstructing his station with an H tube. He got swamped with messages to handle by volunteering to take messages from his office force. He had to turn some of it over to 6RV to clear. 6RM and 6CRR are busy building a combined station. A number of our ORS are still out of the city on business or pleasure trips. Your acting SCM, 6ZT, has become burdened with so much other work that he feels that he can't do the job justice, and must resign soon. A petition to nominate 6RM to fill the vacancy is being circulated. The SCM hopes to find time soon to assemble the transmitter and do some work with the fellows again.

Traffic: 6BTX 30, 6BUH 15, 6AIK 6, 6RM 2.

### SOUTHEASTERN DIVISION

ALABAMA—SCM, A. D. Trum, 5AJP—Well, fellows, DX season is here and there's no reason for not sending in a good report. 5DL has been appointed R-M and O-O for Alabama. Get in touch with him for schedules. Watch your wave, and fist. 5AX and 5DL and many other hams here had the occasion to serve the Southern Bell Telephone Company during the storm period and they sure showed their stuff. 5AX has been hitting the paces at the key. 5AWF has been heard from lately and has the pep as usual. 5MI has the hamfever again and has come back with a good fist and wallop in the ether. 5ASH brags of being a new ham and promises to be a credit to Birmingham. We are wondering what 5JO is going to do with the BCL license. 5DT has come forward as a new model ham, handling quite a bit of traffic already. Bewiz is handling 5VB with the old style ease and pounds the ether for the glory of dear old Auburn. 5DF, 5AGA and 5OA and 5EV are new hams in Auburn, on with 210's. 5DL is rebuilding. He kept in touch with Birmingham, Pensacola, Atlanta, New Orleans and many other places during the storm. 5AC has returned to Mobile to stay and promises to be on soon. 5LC, 5AR, and 5AAD promise to turn in something worth while soon. 5ADA can be classed as a model ham doing splendid work at all times. 5AJP has been keeping schedule with 2CUQ and 2AVK in New York and Newark, sending traffic to his mother who is visiting there. Dothan has come forward again. 5ASR is on the air and worked every district and Canada in one night.

Well, fellows, let's get in a good report next month. The SCM would like some pictures and points on your station for feature work. All hams desiring ORS who can show proof of their deserving one, get in touch with the SCM.

Traffic: 5DL 108, 5EV 38, 5ADA 36, 5AX 29, 5AJP 23, 5DF 20, 5MI 10, 5AWF 9, 5AGA 8, 5ASR 7, 5OA 6.

FLORIDA—SCM, W. F. Grogan, 4QY—Florida hams sure did some fine work during the storm which hit South Florida. 4VS in Miami did some fine work. He and 4FN handled traffic for the Red Cross for four days. 4TK and 4OB lost a fifty. 4OB handled important traffic with a 2YI on KDKA tests. 4HY is stepping out with his H tube—was QSO South Africa. 4TV handled storm traffic direct with Honolulu. 4JZ is still on the job. 4DD says that to save on the light bill, he has been rushing football. 4PK reports handling storm traffic. 4UA says things sure are quite with him, plenty others in the same boat, OM. Hi. 4LK reports that he can't get his traffic south and wants to know if there are any stations in South Florida. How about it, fellows? 4FM reports he will soon be on the air with a high-power crystal set. FB, OM. 4SB was on duty with the National Guards in Miami using his call and reports some fine work done. FB, OM.

Traffic: 4SB 346, 4VS 310, 4OB 50, 4HY 37, 4TV 33, 4DD 22, 4LK 19, 4PK 10, 4TK 9, 4UA 8, 4JZ 2.

## WEST GULF DIVISION

SOUTHERN TEXAS—SCM, E. A. Sahn, 5YK—There is evidence of renewed activity in this section. We have lost one good station, that of 5APM of San Marcos. He has resigned his ORS but we hope that he will soon be with us again. 5AVI-5ARF report good DX and show up well for their first report. 5ALH is still handicapped by a very poor power supply. The Wilsons of Bronsville report a great scarcity of traffic. 5ZU is going again with a brand new layout. We are glad to see him in the ranks again. Tilley is Father of South Texas radio, having just begun his 14th year of amateur radio. San Antonio is represented by 5HS, and 5HC. ORS have just been granted to 5AHP and 5ABQ. Glad to have these newcomers. A promising young ham, Irving Seligman, is coming up at Seguin.

Traffic: 5ZU 13, 5AVI-5ARF 9.

NORTHERN TEXAS—SCM, W. B. Forrest, 5AJT—Our Section is not making the showing that it should for this time of the year. Please mail your report each month to the SCM. There are several active stations that are not getting credit for work done, because they are not reporting. This also holds down our section standing.

5DW has dropped to 20 meters for daylight work and likes it. 5NW-5MZ is still operating at Corsicana, Texas. 5WW has just returned from Fort Sam Houston, where he has been attending the Officers' Training Camp. He visited with WVB, 5AIN, and other South Texas stations. 5SP reports QSO with Africa. 5AKN is now using xtal control on 161.6, 80, 40 and 15 meters. He reports that the Palm-to-Pine Excursion didn't give them half the traffic they wanted. In fact, Whitaker and Lovelady (5FC) went to the Adolphus to see the people concerned, but were given the ice box by the hotel manager. Hi. 5ACL took a bunch of press and other traffic this month from VOQ. He is rebuilding his station for a tuned grid and plate circuit. 5ACL has been picked by AQE to handle his news items and traffic. Good work, OM. 5HY is busy with school work. 5AUA wants some schedules on 80 meters. 5AJJ is moving to 6918 Pasadena Ave. and will be back on the air by the time you read this report. 5AFU, Waco, is on Sundays, only. 5PH reports that old 5ADH will be back with him as another op for the station. 5AKL put up a new antenna, blew his 50-watter, is trying to get out now with only 20 watts and is hoping that Santa Claus will leave him another fifty this Xmas. 5RG has had a distinguished guest, "UG" from Telegrapha, Honduras, C. A., an operator for the United Fruit Co. His guest will return soon and will be "UR" in Costa Rica and will try to keep communication with Dallas hams on about 42 meters with a kilowatt station. 5AMB is busy with business.

5AQ and 5AMT are sending in their first reports this month. The rest of you fellows who are not report, please do so in the future.

Traffic: 5NW 18, 5AKN 13, 5AJJ 10, 5ACL 6, 5RG 6, 5AQ 6, 5AMT 5, 5AUA 4, 5HY 2, 5SP 2, 5WW 1.

OKLAHOMA—SCM, K. M. Ehret, 5APG—5ASK is too busy with college and YLs to keep schedules but handles a few messages. 5DQ says he has had transmitter trouble but is going good now. 5ANL has been appointed RM for his vicinity and has convinced his gang that ORS is the thing to have. 5ANL is getting up a route map which we hope to publish soon. 5ADO is much peeved and thinks he has transmitter trouble because he can't work an Aussie or NZ every night. Hi. Too bad. Working two South Africans indicates that he is wrong about the transmitter. 5APG is using a so-called "impractical voltage multiplier" that does its stuff and keeps the plates warm these chilly nights. 5AAV worked O-55B and Iceland and asks why the SCM doesn't stay home. 5AGN reports serious QRM from the Profs. at O. U. but manages to work week-ends. 5ABO is building a 40 meter B battery operated transmitter.

5TW kept schedules with 21 different stations with three HE operators and one SHE operator. Chief Op. Harris says all of 'em are good ops. They are handling some press news, which goes to show that ham radio is practical and justified. Watch his smoke, gang.

5AHD has his set in operation again and is located in a new shack. EP, 5FJ and 5AMO are in operation at Norman and are handling traffic. 5FJ handled Ark.-O. U. football game, play-by-play with 5AZ. 5AMO is a new League member. Norman will be the scene of a Conventionette on November 8th. Watch next month's QST for postmortem. We confess we are getting better, gang, but there is still room for improvement and we surely need more reports, so get busy!

Traffic: 5TW 330, 5AMO 108, 5FJ 12, 5AHD 7, 5AAV 20, 5ADO 21, 5ANL 43, 5AGN 21, 5ASK 12, 5DQ 4, 5SW 58.

## CANADA

### MARITIME DIVISION

NEW BRUNSWICK—SCM, T. B. Lacey, 1EI—1AX is on every day at noon, on 39 meters with a home-made bug key. 1AK has started up again on 42 meters and has three daily schedules. Most work is between 11 a.m. and 2 p.m. 1AM is also on for the winter with pure d.c. note. 1AN can't seem to keep his H-tube perking, but is on often. 1AF is in St. John studying law. There will be a Mrs. 1AF next month. Good luck, OM. 1AD says he isn't taking any chances on hearing foreign stations and not being able to QSO so just bought a 250 watter. 1AI is having trouble getting his new electric light plant and power supply for his transmitter hooked together. 1EI is rebuilding his receiver and starting up with a 150-watter. 1AQ also has a new tube and is on every evening. Station 10BO, which is operated by F. D. Thorne and 1EL has had a receiver on short waves and will be transmitting soon. They would like to have a report on signals from all hearing them. Out of 11 stations now in operation it would be interesting to note that there are three 250 watters, two 150, three 50, one 20 and 2 fivers.

Traffic: 1AK 9, 1AM 8, 1AX 3, 1AD 3.

PRINCE EDWARD ISLAND—SCM, W. T. Hyndman, 1BZ—Reports are rather lacking in this section—only the SCM reporting.

Traffic: 1BZ 4.

NOVA SCOTIA—SCM, W. C. Borrett, 1DD—Things are looking up in Nova Scotia with winter coming on. Ten new members have been secured in Halifax. A class of seventeen has been started by the Halifax County Radio Association for those who want to become hams. FB. C. H. Starr, c3KA, has returned to NS to college and will have a 1 call going soon. 1ED is now at Kings in Halifax and has started the Hertz antenna craze going there. 1DD has a Hertz going and 1DQ is now constructing one. 1DA and 1CX have been QSO Europe several times. 1DM used about 600 feet of wire trying to get a Hertz working. Hi. 1BF and 1AE (Glace Bay) are



now on the air on low power. 1CX is the star Cape Breton station.

1AR is pounding away as usual. 1DJ promises to come to life again soon. Ken Ritchie, ex Commercial op of Halifax, has a ham set almost ready for 40 meters a la Hertz.

WILL ALL NOVA SCOTIA STATIONS PLEASE USE 52 METERS SUNDAYS 1 TO 5 PM WEEK NIGHTS 6 TO 8 PM. PLEASE MAKE SPECIAL EFFORT AT THESE TIMES SO OTHER CANADIANS CAN FIND US.

PLEASE SUPPLY YOUR TRAFFIC FIGURES TO 1DD EACH MONTH BY THE 20TH.

Traffic: 1CX 9, 1DD 4.

#### QUEBEC DIVISION

QUEBEC—SCM, Alex Reid, 2BE—The SCM wishes to thank all the members who loaned their gear and gave of their time so generously at the recent Radio Show. Special mention should be given to 2AU, 2BB, 2DO, 2BM, 2CM, 2BV, 2AL, 2CC, 2HV and the Northern Electric Company, Eveready Battery Co. and Burgess Battery Co. The booth was very attractive. A display of old time gear, also three modern transmitters, one of which was in operation was given. Over 170 messages were sent during the week and a great number of replies received. One corner of the booth represented a ham shack with real Ham Wall Paper, A.R.R.L. emblem and operating license. The station call for the week was 2BM. 2BV, 2DO and 2BG are on again with new sets and getting out well. 2FO has a new sync and is tearing large holes in the ether. 2BE added three countries to his log during the month. 2AX has blown his big bottle and is using low power for the present. 2BM has been appointed Central City Manager and is showing lots of pep. E. Gannon has been appointed Publicity Manager. 2AL has received his appointment as an OBS. The SCM has a report from Vandray at Waterloo, Que. that 2AK is now in operation and looking for traffic. It seems a shame that we cannot get stations at Sherbrook, Three-Rivers and Quebec as there is a great amount of traffic refused for those points.

Traffic: 2AX 41, 2BE 73, 2BM 19.

#### ONTARIO DIVISION

ONTARIO—SCM, W. Y. Sloan, 9BJ—New C M APPOINTMENTS PROMISE INCREASED ACTIVITY IN CENTRAL DISTRICT. 3IA OF ST. THOMAS APPOINTED NEW ASSISTANT SECTION MANAGER OF SOUTHERN DISTRICT. 3CS OF LONDON, STAR BRASS POUNDER OF THE DIVISION.

The past month has been one of feverish activity, as far as the radio exhibition and fall fairs are concerned. Stations have been installed and operated from A.R.R.L. exhibits at both London and Hamilton and at the time of writing, the Toronto Radio Show is going full blast, with an exhibit installed by the local club. Hill (4AJ-9BJ) has his celebrated low-power "DX getter" on display, and perking merrily for the edification of the BCLs.

3ZB has found it necessary, owing to his return to college, to relinquish his job as ASM of the Southern District. He has been right on the job and it is with regret that we announce his retirement. 3IA of St. Thomas is taking over 3ZB's office and he promises to put some ZIP into the Southern District this winter.

No reports are to hand from the Eastern Division. Reports must reach the SCM by the 21st of EVERY month for inclusion in the Division report.

Northern District: 3AA reports using voltage-feed Hertz as per u8GZ and is reaching out in great style. It is with great pleasure that we are able to make the announcement that 3BG is now feeling fit again and will soon be heard back on the air pounding brass. Nothing heard from 3GG this month. 3HT leads in traffic this month.

Southern District: 3CS is the shining light in this district, handling over a hundred messages. This new station promises that things are going to hum around London this winter. 3IA is on again with 80 meters and scanning the Heaviside Layer for traffic. 3ACO has a new fifty perking. At last, 3UD has joined the ranks and will help to keep traffic moving. 3CB, 3CA, 3CM, ex 3UJ, 3CN, 3BB, 3XN, 3LW and 3DU are about ready to go on the air. Here's hoping that 9BT will be going by the time this is printed.

Central District: 3BT, the new CM of Hamilton, reports that things are being pepped up there in great shape. They have passed safely through the throats

of a Radio Show which left them swamped with traffic. 3BT is using two fivers, but is on the lookout for a couple of fifties. He is on the air every a.m. 3CT manages to reach out on 80 with his 201-A. 3HT has been doing some experimenting with kenotrons. 3HR is tickling a new Hertz. 3BZ is another new station that promises well. 3WG is heard keeping things warm during the week-ends. 3CC is busy rebuilding and will have 3CR there on the air using a fiver with break-in.

In Toronto, things seem very quiet but we hope it is but the calm before all the activity breaks loose. 3BR is back again after his trans-continental radio tour. 9AL and 3FC were QSO Mr. Hebert who was at the key at 4DW at Winnipeg. 9BJ is back from the island and on the air using low power. Real results are looking for when the big lantern gets pushing the double-barreled Hertz. 3FC tested out his new rectifier by working Denver and El Paso on indoor aerial. Watch for him on 21 meters every Sunday from now on. 3UR, 3AJ, 3NJ, 3AO, 3EL, 3CK, 3AZ and 3BY are heard banging away consistently.

Traffic: 3CS 101, 3BT 32, 3IA 30, 3HT 23, 9AL 15, 3EL 8, 3BY 6, 3FC 5, 9BJ 3, 3DO 1.

#### PRAIRIE DIVISION

MANITOBA—SCM, F. E. Rutland, 4DE.—A committee of two has been appointed to work out schedules for all active Winnipeg stations whereby consistent traffic handling by schedule may become an established fact instead of a pleasant dream. Particular attention is being given to the 52.5 meter band for all-Canadian work. A campaign for new brass pounders has been started through the medium of the local broadcasting station in the form of code instruction for the beginner. After only one lesson being put out, the local gang headquarters has been swamped for copies of the code, etc. The Winnipeg Convention was held on the 28th of Sept. and proved another triumphant success. Mr. Hebert of HQ was present and gave a very interesting talk on our organization which opened the eyes of many. 4DY has a new Hertz antenna and gets out PUNK. 4DU is in the new location and reports good DX. 4EA is on again and still uses raw ac. 4EK gets out well with two 201-A's and B supply. 4DW is still going strong with a fiver that has had its filament fractured no less than 4 times. Mr. Hebert worked Toronto on 52 with it and the filament is still good. HI. 4FO is a new station using 201-A's to start with but has a fifty watter all ready to go. He is responsible for the code classes for BCLs from CLY. Sure PB. 4AW continues as ever and has yet to fail for the first time in reporting. 4BT has gone to the States to attend school. 4FZ has his 50-watter ready and is busy with a new stick. 4EH and his YL 2nd op put out a good note but 4EH reports it doesn't get anywhere. (better try two pairs of fones, OM). 4DF complains of cobwebs on his set through QRW servicing BCL grief. He hopes to do biz CQing soon. 4DE has been out of commission pending a new power transformer which at last arrived.

Traffic: 4DY 24, 4DU 9, 4DW 8, 4DF 2, 4AW 6, 4EA 5, 4EK 3, 4FO 3.

#### VANALTA DIVISION

ALBERTA—SCM, A. H. Asmussen, 4GT—4AH is busy building up a real xmitter (crystal control) but handled some traffic with the old set. 4CL is now perking with a new H-tube and is combing the ether for DX. 4CS is working under difficulties but is getting out FB. 4DG has applied for an ORS and promises to turn in some real reports. 4HM is working consistently and will sure put the Capital City on the ham map. 4JF and 4EF are QRW rebuilding. 4AF was in the City the other day with a sample of his Hay Wire Bug Key (mostly phord) and got enough orders to keep him off the air for a while. Be careful, gang, when QSO with 4DQ as the OW may be at the key. HI. 4EB is back on the air with a real transmitter and should turn in a good report for next month. 4GT is home only at week-ends so the old bottle is getting a rest. 4IO is busy rehatching his MO and making a portable receiver to take on a hunting trip. 4BN, a new ham, is putting out good sigs with a low power set and wants to QSO the gang. The gang was sure glad to meet Mr. Hebert from Headquarters.

Traffic: 4DQ 6, 4IO 4, 4GT 2, 4AX 2, 4AH 1.  
BRITISH COLUMBIA—5GT blew a rectifier tube but will soon be on again.